



5143R

355mm Circular Saw

Equipped with **SJS** (Super Joint System)



SUPER JOINT
SYSTEM
SJS

2,200W

HIGH POWER 2,200W MOTOR

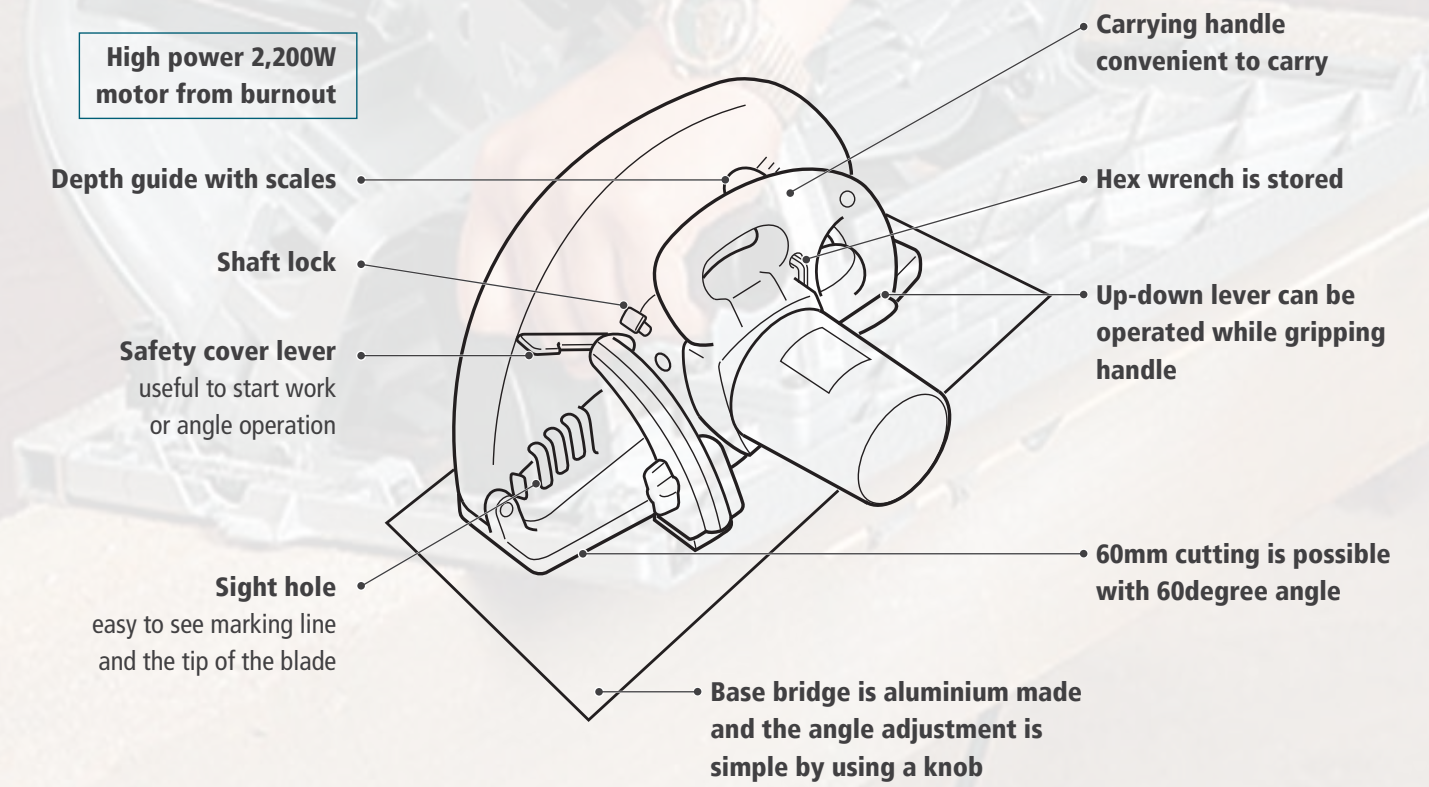

OPTIONAL ACCESSORIES

Carbide Tipped Saw Blade: Part No. A-80014



SPECIFICATIONS

Outer dia. (mm)	Bore (mm)	Kerf (mm)	No. of teeth	Material
355	30	3	20	Wood

SPECIFICATIONS

203mm

Continuous rating input	2,200W
Blade diameter	355mm
Max. cutting capacity	90°: 130mm
	45°: 90mm
No load speed (rpm)	2,700
Overall length	607mm
Net weight	12.5kg

 Double Insulation

 Soft Start

 Brake

 Dust Collecting

Standard Equipment:

Rip fence, Hex wrench, Carbide tipped saw blade (355-20T), Joint assembly.



Makita[®]
Makita Gulf FZE
www.makita.ae