

# Model No.4333D CORDLESS JIG SAW

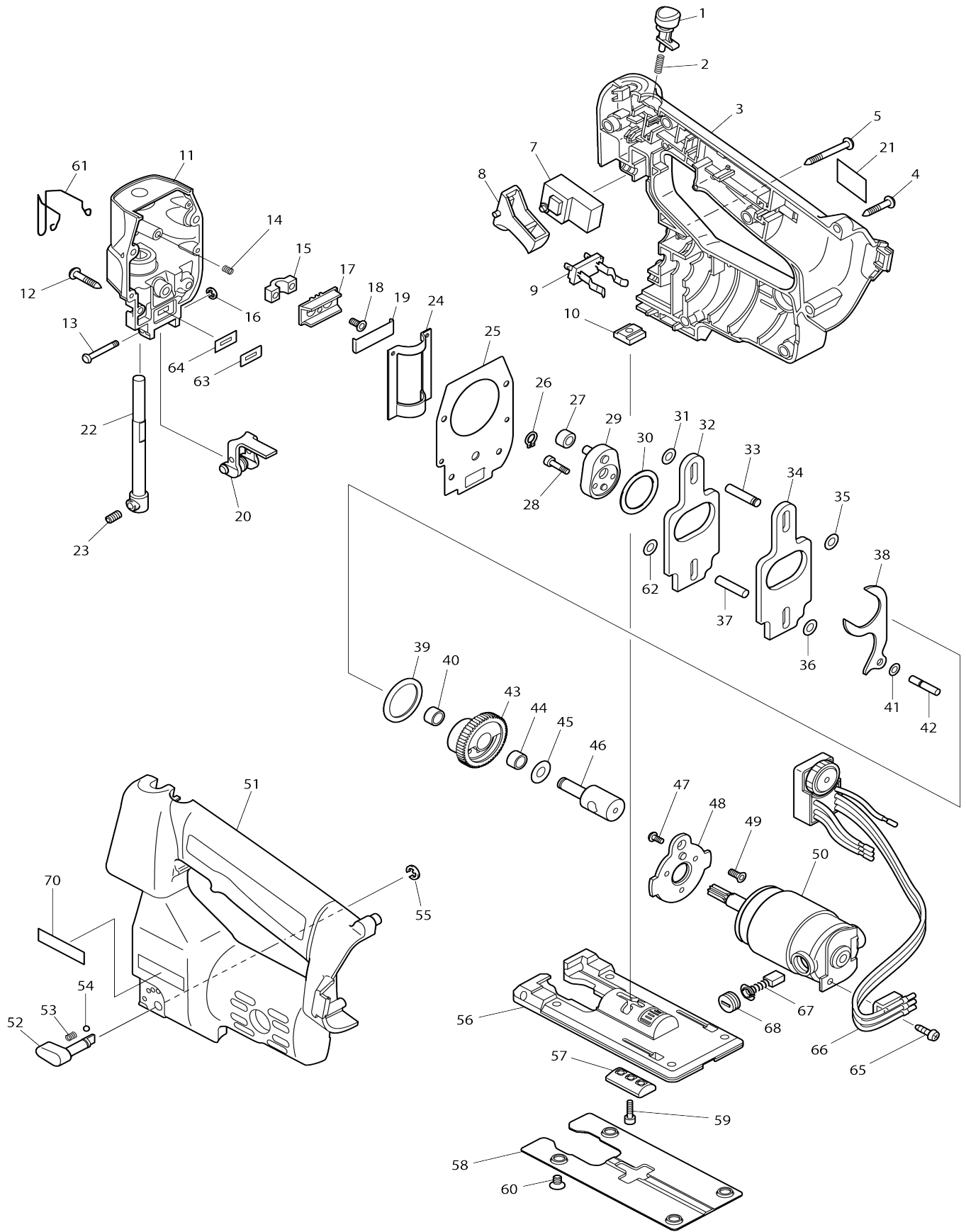

Model No.4333D CORDLESS JIG SAW

Item No.	Parts No.	Description	Interchangability	Q'ty	New/Old	Note1	Note2
001	416644-0	SWITCH BUTTON		1			
002	233194-8	COMPRESSION SPRING 4		1			
003	183268-4	HOUSING SET		1			
D10		INC. 51,70					
004	265995-6	TAPPING SCREW 4X18		7	*		
004-1	265A48-7	TAPPING SCREW 4X18	O	7			
005	266050-7	TAPPING SCREW 4X30		1			
007	651976-0	SWITCH TG73BD		1			
008	416642-4	SWITCH LEVER		1			
009	643918-8	BATTERY HOLDER		1			
010	164749-7	HOLDER		1			
011	152645-1	GEAR HOUSING COVER COMPLETE		1	*		
011-1	153391-9	GEAR HOUSING COVER COMPLETE	<	1			
C10	253310-6	THIN WASHER 10		1			
C20	421821-1	DUST SEAL 8		1			
012	265995-6	TAPPING SCREW 4X18		4	*		
012-1	265A48-7	TAPPING SCREW 4X18	O	4			
013	256693-3	PIN 4		1			
014	231314-8	COMPRESSION SPRING 4		2			
015	316608-3	HOLDER		1			
016	961017-7	STOP RING E-3		1			
017	310028-3	SLIDER		1			
018	265035-0	COUNTERSUNK HEAD SCREW M4 X10		2			
019	344232-2	THRUST PLATE		1			
020	151426-0	RETAINER COMPLETE		1	*		
C10	256667-4	PIN 4		1	*		
C20	322709-7	ROLLER		1	*		
C30	961017-7	STOP RING E-3		1	*		
020-1	152947-5	RETAINER COMPLETE	X	1			
C10	268074-9	PIN 4		1			
C20	152950-6	ROLLER COMPLETE		1			
C30	961017-7	STOP RING E-3		1			
021	852647-4	NAME PLATE 4333D		1			
022	165089-6	ROD		1			
023	265894-2	H.S.SET SCREW(CUP POINT) M6X 8		1			
024	344137-6	SLIDE PLATE		1			
025	421692-6	GASKET		1			
026	961004-6	RETAINING RING (EXT) S-8		1			
027	212010-7	NEEDLE BEARING 607		1			
028	922126-7	HEX. SOCKET HEAD BOLT M4X16		2			
029	152454-8	CRANK COMPLETE		1			
030	253792-2	FLAT WASHER 26		1			
031	253715-0	FLAT WASHER 6		1			
032	344792-4	BALANCE PLATE		1			
033	256289-0	PIN 6		1			

034	344792-4	BALANCE PLATE		1		
035	253715-0	FLAT WASHER 6		1		
036	253715-0	FLAT WASHER 6		1		
037	256143-8	PIN 6		1		
038	344134-2	PUSH PLATE		1		
039	253792-2	FLAT WASHER 26		1		
040	212043-2	NEEDLE BEARING 810		1		
041	253811-4	FLAT WASHER 5		1		
042	256235-3	PIN 5		1		
043	226428-6	HELICAL GEAR 51		1		
044	212043-2	NEEDLE BEARING 810		1		
045	253139-0	FLAT WASHER 8		1		
046	256288-2	PIN 8		1		
047	266134-1	TAPPING SCREW ST 4X8		3		
048	344791-6	MOTOR BRACKET		1		
049	265035-0	COUNTERSUNK HEAD SCREW M4 X10		1		
050	629740-7	DC MOTOR 14.4V		1		
C10	226385-8	HELICAL GEAR 8		1		
D10		INC. 67,68				
051	183268-4	HOUSING SET		1		
D10		INC. 3,70				
052	272231-3	LEVER 17		1		
053	231314-8	COMPRESSION SPRING 4		1		
054	216008-6	STEEL BALL 4		1		
055	961018-5	STOP RING E-5		1		
056	316883-1	BASE		1		
057	331435-7	CLAMP PLATE		1		
058	344443-9	BASE PLATE		1		
059	922126-7	HEX. SOCKET HEAD BOLT M4X16		1		
060	266055-7	HEX. SOCKET HEAD BOLT M5X8		4		
061	322893-8	SAFETY WIRE		1		
062	253715-0	FLAT WASHER 6		1		
063	344784-3	SEAL PLATE		1		
064	443106-5	FELT 10-20		1		
065	911006-2	PAN HEAD SCREW M3X8		1		
066	631372-8	CONTROLLER		1		
067	191971-3	CARBON BRUSH CB-430		1		
068	643929-3	BRUSH HOLDER CAP		2		
070	819080-3	MAKITA LABEL		1		
A01	414938-7	BATTERY COVER		1		
A02	415524-7	ANTI-SPLINTERING DEVICE		1		
A03	783201-2	HEX. WRENCH 3		1		
A04	792522-1	JIG SAW BLADE B-22		1	*	
A04-1	A-85737	JIGSAW BLADE NO.B22	<	1		
A05	792538-6	JIG SAW BLADE B-10		1	*	
A05-1	A-85628	JIGSAW BLADE NO.B10	<	1		
A06	A-02294	JIG SAW BLADE BR-13		1	*	
A06-1	A-85793	JIGSAW BLADE NO.BR13	<	1		
A07	824553-3	PLASTIC CARRYING CASE		1		
C10	416661-0	LATCH		2		
A08	192600-1	HIGH CAPACITY BATTERY 1422 S		1		

		ET				
E01	414938-7	BATTERY COVER		1		
E03	192600-1	HIGH CAPACITY BATTERY 1422 S ET		1		
A08C_	193101-2	BATTERY 1434 SET		1	*	
A08C 1	193101-2	BATTERY 1434 SET	O	1		
E05	193101-2	BATTERY 1434 SET		1	*	
E05-1	193101-2	BATTERY 1434 SET	O	1		

Please state Parts No. when your order.

Print Date 10/06/2023