

Model No.6018D CORDLESS DRILL 10MM

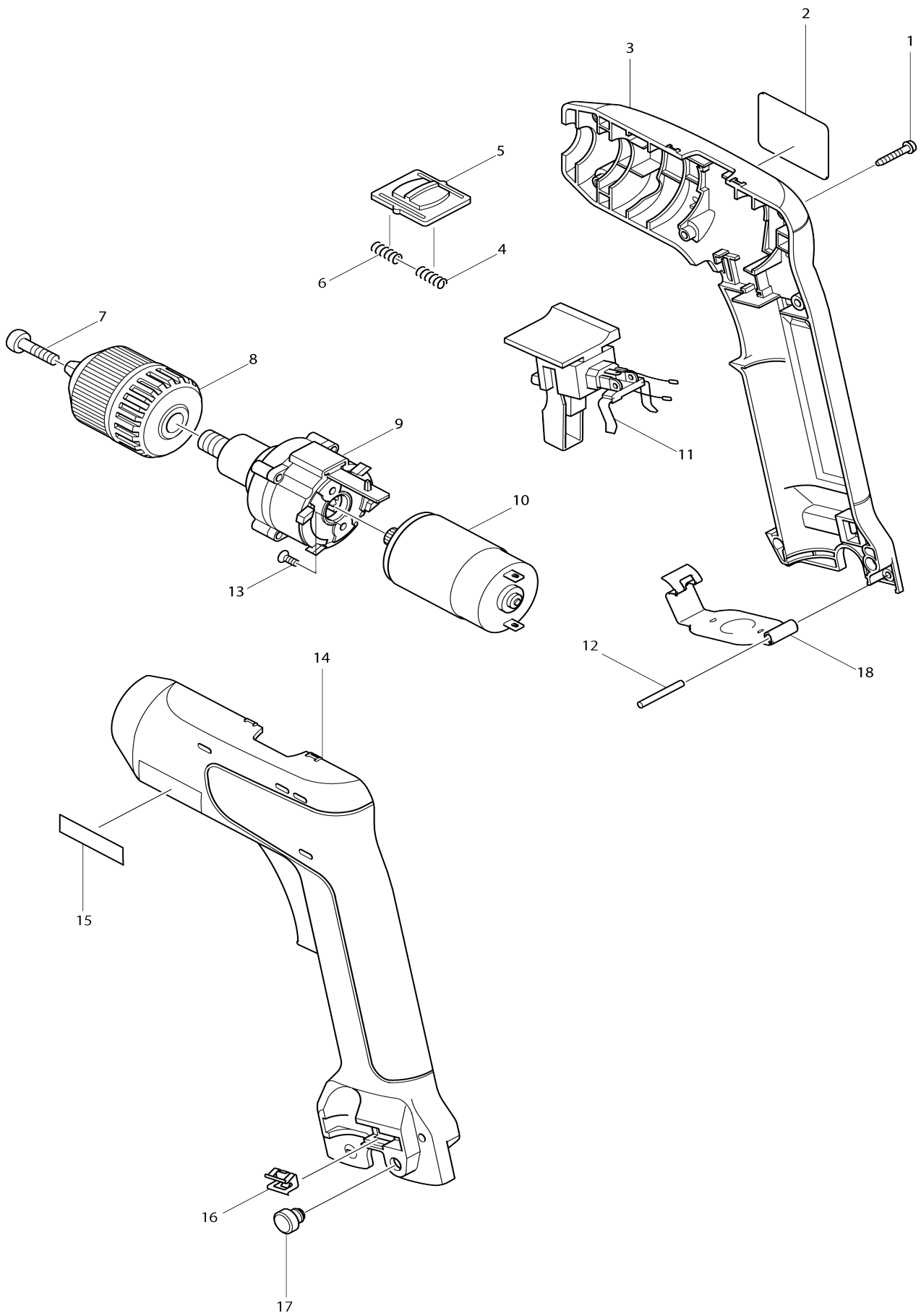

Model No.6018D CORDLESS DRILL 10MM

Item No.	Parts No.	Description	Interchangeability	Q'ty	New/Old	Note1	Note2
001	266130-9	TAPPING SCREW BIND PT 3X16		7			
002	858381-4	Name plate 6018D		1			
003	182834-4	Housing set (blue)		1			
D10		INC. 14,15					
004	231433-0	COMPRESSION SPRING 4		1			
005	416119-9	Speed change lever		1			
006	231433-0	COMPRESSION SPRING 4		1			
007	251457-0	- PAN HEAD SCREW M5X20		1			
008	763119-3	KEYLESS DRILL CHUCK 10		1	*		
008-1	192016-0	KEYLESS DRILL CHUCK 10	O	1	*		
008-2	193601-2	Keyless drill chuck set	O	1			
009	125049-0	Gear assembly		1			
010	629708-3	DC motor		1	*		
C10	226316-7	Spur gear 10		1	*		
010-1	629779-0	DC motor	<	1	*		
C10	226316-7	Spur gear 10		1	*		
010-2	629779-0	DC motor	O	1			
C10	226316-7	Spur gear 10		1			
011	531076-1	Switch assembly		1	*		
011-1	531078-7	Switch assembly	O	1			
C10	654086-2	RECEPTACLE		2	*		
C11	654069-2	RECEPTACLE	O	2			
012	256252-3	PIN 3		1			
013	912002-3	COUNTERSUNK HEAD SCREW M3 X6		2			
014	182834-4	Housing set (blue)		1			
D10		INC. 3,15					
015	819720-3	MAKITA LABEL		1			
016	344391-2	BIT HOLDER		2			
017	263022-3	RUBBER PIN 6		2			
018	344549-3	SET PLATE		1			
A01	414938-7	BATTERY COVER		1			
A02	784202-3	PHILLIPS BIT 2-45		2	*		
A02-1	784202-3	PHILLIPS BIT 2-45	O	2	*		
A02-2	784637-8	+ - BIT 2-45	X	2			
A03	824475-7	PLASTIC CASE		1	*		
C10	183091-7	SLIDE LATCH RL SET		1	*		
A03-1	824723-4	PLASTIC CARRYING CASE	<	1			
C10	183091-7	SLIDE LATCH RL SET		1			
B01	191679-9	BATTERY 7000 SET		1	*		
B01-1	193888-6	Battery set 7034	<	1			
B02	***DC9700	DC9700 FAST CHARGER		1	*		
B02-1	***DC1414	DC1414 BATTERY CHARGER	<	1			
E01	414938-7	BATTERY COVER		1			
E02	191679-9	BATTERY 7000 SET		1	*		
E02-1	193888-6	Battery set 7034	<	1			

Please state Parts No. when your order.

Print Date 10/24/2023