

Model No.6843 AUTO FEED SCREWDRIVER

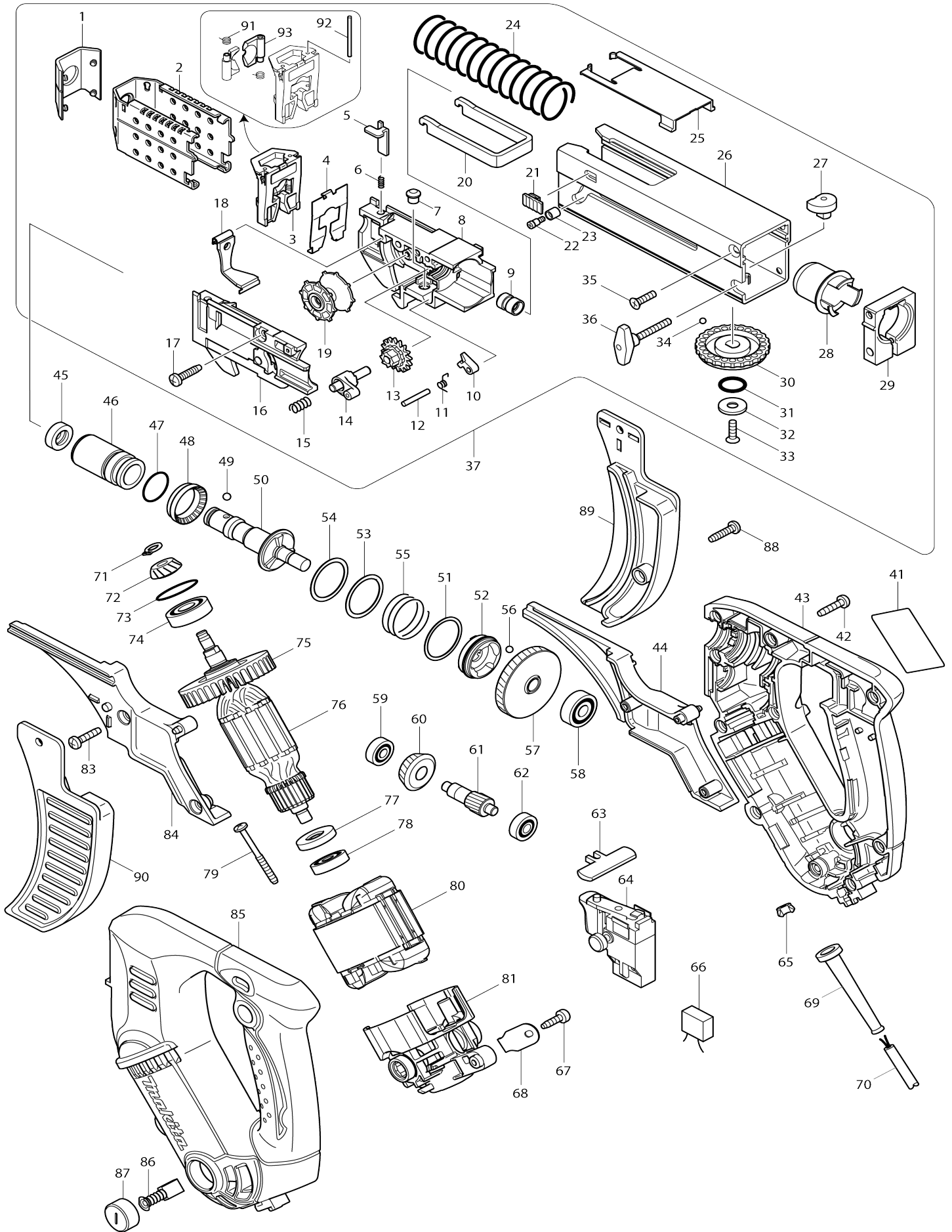

Model No.6843 AUTO FEED SCREWDRIVER

Item No.	Parts No.	Description	Interchangability	Q'ty	New/Old	Note1	Note2
001	424043-2	CAP		1			
002	345839-7	STOPPER BASE 55		1			
003	158376-0	GUIDE BOX COMPLETE		1	*		
D10		INC. 91,92,93					
003-1	158776-4	GUIDE BOX COMPLETE	O	1	*		
D10		INC. 91,92,93					
003-2	140493-0	GUIDE BOX COMPLETE	S	1			
D10		INC. 4,91,92,93					
004	345840-2	GUARD		1	*		
004-1	346269-5	GUARD	S	1			
005	345837-1	LEVER		2			
006	233211-4	COMPRESSION SPRING 2		2			
007	256451-7	PIN 6		1			
008	450107-6	FEEDER BOX		1	*		
008-1	412963-2	FEEDER BOX	<	1			
009	257685-5	SLEEVE 5		1			
010	310062-3	STOPPER		1			
011	231636-6	TORSION SPRING 4		1			
012	256158-5	PIN 3		1			
013	226344-2	SPUR GEAR 16		1			
014	158374-4	RATCHET ARM COMPLETE		1			
015	233212-2	COMPRESSION SPRING 6		1			
016	158375-2	BOXCOVER COMPLETE		1			
017	265995-6	TAPPING SCREW 4X18		1			
018	162201-9	DUST COVER		1	*		
018-1	162934-6	DUST COVER	>	1			
019	416518-5	WHEEL		1			
020	345838-9	PLATE		1			
021	450111-5	STOPPER		2			
022	265177-0	+SHOULDER FLAT HEAD SCREW M3X5		1			
023	257764-9	SLEEVE 4		1			
024	234031-9	COMPRESSION SPRING 23		1			
025	450114-9	CASING COVER		1			
026	158377-8	CASING 55 COMPLETE		1			
C10	816885-2	INDICATION LABEL		1			
027	310237-4	SHIFTER PIN		1			
028	450110-7	INSULATION SLEEVE		1			
029	318181-9	CLAMPER		1			
030	417056-0	DIAL 42		1			
031	213107-5	O RING 12		1			
032	267201-5	FLAT WASHER 6		1			
033	912117-6	COUNTERSUNK HEAD SCREW M4 X12		1			
034	216001-0	STEEL BALL 3.5		1			
035	912117-6	COUNTERSUNK HEAD SCREW M4 X12		3			
036	265778-4	THUMB SCREW M4X28		1	*		

036-1	265779-2	THUMB SCREW M4X28	<	1		
037	194440-3	CASING 55 SET		1	*	
D10		INC. 1-36				
037-1	194544-1	CASING 55 SET	<	1	*	
D10		INC. 1-36				
037-2	194636-6	CASING 55 SET	O	1	*	
D10		INC. 1-36				
037-3	195184-8	CASING 55 SET	<	1		
D10		INC. 1-36				
041	863782-3	6843 NAME PLATE		1		
042	266045-0	TAPPING SCREW 4X20		10		
043	188345-7	HOUSING SET		1		
C10	812552-7	INDICATION LABEL		1		
D10		INC. 85				
044	188303-3	SCREW GUIDE SET		1		
D10		INC. 84				
045	421467-3	DUST COVER		1		
046	214173-5	PLANE BEARING 14		1		
047	213262-3	O RING 18		1		
048	421927-5	SLEEVE 20		1		
049	216001-0	STEEL BALL 3.5		1		
050	324808-1	SPINDLE B		1		
051	267332-0	FLAT WASHER 26		1		
052	223169-5	CLUTCH CAM C		1		
053	267331-2	FLAT WASHER 25		1		
054	267331-2	FLAT WASHER 25		1		
055	234017-3	COMPRESSION SPRING 25		1		
056	216008-6	STEEL BALL 4		3		
057	226659-7	HELICAL GEAR 53		1		
058	210029-0	BALL BEARING 608ZZ		1	*	
058-1	211034-0	BALL BEARING 608	<	1		
059	210028-2	BALL BEARING 606ZZ		1	*	
059-1	211014-6	BALL BEARING 606	<	1		
060	227528-5	SPIRAL BEVEL GEAR 22		1		
061	226669-4	HELICAL GEAR 16		1		
062	210028-2	BALL BEARING 606ZZ		1	*	
062-1	211014-6	BALL BEARING 606	<	1		
063	419304-3	F/R CHANGE LEVER		1		
064	650590-9	SWITCH SGEL206CR-1		1	*	
064-1	650590-9	SWITCH SGEL206CR-1	O	1		
065	252045-6	SQUARE NUT M5		1		
066	645253-0	NOISE SUPPRESSOR		1		
067	266192-7	TAPPING SCREW 4X14		1		
068	687169-3	STRAIN RELIEF		1		
069	682559-5	CORD GUARD 8		1		
070	695034-2	POWER SUPPLY CORD 1.0-2-4.0		1		
071	961002-0	RETAINING RING S-6		1		
072	227527-7	SPIRAL BEVEL GEAR 15		1		
073	213380-7	O RING 24		1		
074	211061-7	BALL BEARING 6000LLB		1		
075	241869-5	FAN 55		1		
076	515713-5	ARMATURE ASS'Y 220-240V		1		

D10		INC. 74,75,77,78				
077	681652-2	INSULATION WASHER		1		
078	211021-9	BALL BEARING 607LLB		1		
079	266069-6	TAPPING SCREW 4X45		2		
080	639372-2	FIELD 220-240V		1		
081	158380-9	ENDBELL COMPLETE		1		
083	265995-6	TAPPING SCREW 4X18		2		
084	188303-3	SCREW GUIDE SET		1		
D10		INC. 44				
085	188345-7	HOUSING SET		1		
C10	812552-7	INDICATION LABEL		1		
D10		INC. 43				
086	191940-4	CARBON BRUSH CB-411		1	*	
086-1	195010-1	CARBON BRUSH SET CB-411	O	1		
087	643928-5	BRUSH HOLDER CAP		2		
088	265995-6	TAPPING SCREW 4X18		1	*	
088-1	265995-6	TAPPING SCREW 4X18	S	2		
089	188310-6	GUIDE ATTACHMENT SET		1	*	
D10		INC. 90				
089-1	188310-6	GUIDE ATTACHMENT SET	S	1		
D10		INC. 90				
090	188310-6	GUIDE ATTACHMENT SET		1	*	
D10		INC. 89				
090-1	188310-6	GUIDE ATTACHMENT SET	S	1		
D10		INC. 89				
091	233516-2	TORSION SPRING 4		2	*	
091-1	233567-5	TORSION SPRING 4	S	2		
092	268188-4	PIN 2		2		
093	310236-6	GUIDE		2	*	
093-1	310282-9	GUIDE	O	2		
094	125809-0	FEEDER BOX ASS'Y		1		
D10		INC. 1-3,5-19,22,23				
A01	265734-4	SCREW M5X13		1		
A02	345831-3	HOOK		1		
A03	784252-8	+BIT 2-157		3	*	
A04	824808-6	PLASTIC CARRYING CASE		1		
C10	163455-1	LATCH		2		
C20	419360-3	HANDLE		1		
F07	194500-1	EXTENSION HANDLE SET		1		
F08	191B45-2	CASING 55 SET		1		
A03	784655-6	+BIT 2-160		3		
A04	142715-4	CONNECTOR P.CASE(TYPE1) CO MP.		1		
C10	453974-8	LATCH		4		
A05	803B58-8	6843J INDICATION LABEL		1		
A06	803B59-6	6843J PLASTIC CASE LABEL		2		
A07	837876-0	INNER TRAY		1		
A05	803W85-1	6843JX INDICATION LABEL		1		
A06	803W86-9	6843JX PLASTIC CASE LABEL		2		

Please state Parts No. when your order.

Print Date 27/12/2023