

Model No. BO4900V FINISHING SANDER

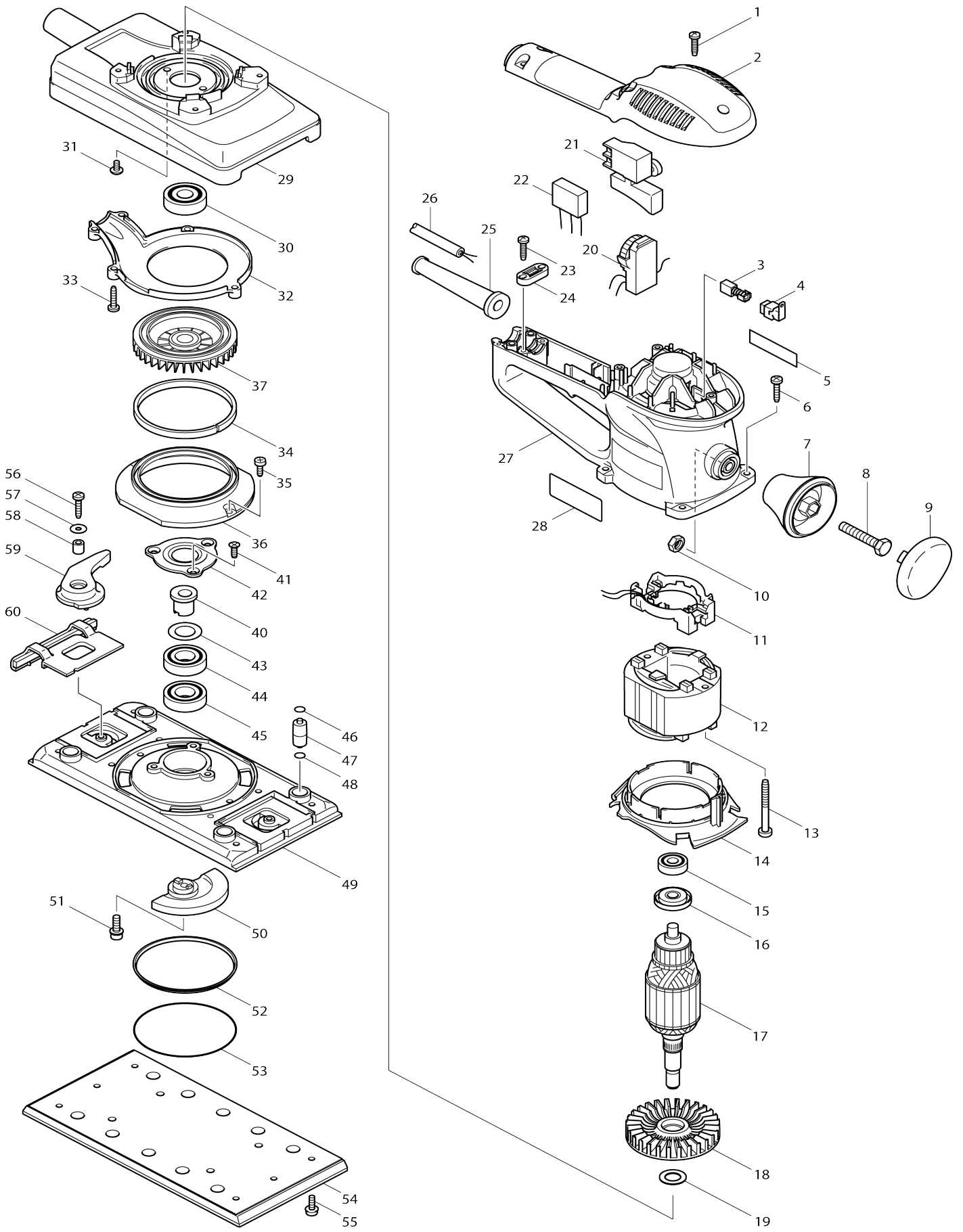

Model No.BO4900V FINISHING SANDER

| Item No. | Parts No. | Description | Interchangability | Q'ty | New/Old | Note1 | Note2 |
|----------|-----------|-----------------------------|-------------------|------|---------|-------|-------|
| 001 | 265995-6 | TAPPING SCREW 4X18 | | 5 | | | |
| 002 | 417778-2 | TOP COVER | | 1 | | | |
| 003 | 191962-4 | CARBON BRUSH CB-419 | | 1 | * | | |
| 003-1 | 195015-1 | CARBON BRUSH SET CB-419 | O | 1 | | | |
| 004 | 643923-5 | BRUSH HOLDER | | 2 | | | |
| 005 | 819063-3 | MAKITA LABEL | | 1 | | | |
| 006 | 266042-6 | TAPPING SCREW BIND CT 4X20 | | 4 | | | |
| 007 | 417774-0 | KNOB | | 1 | | | |
| 008 | 921467-8 | HEX. BOLT M8X45 | | 1 | | | |
| 009 | 417775-8 | KNOB COVER | | 1 | | | |
| 010 | 931403-6 | HEX. NUT M8 | | 1 | | | |
| 011 | 638135-3 | SUPPORT COMPLETE | | 1 | * | | |
| 011-1 | 632R03-0 | SUPPORT COMPLETE | < | 1 | | | |
| 012 | 634464-2 | FIELD 230-240V | | 1 | | | |
| 013 | 266046-8 | TAPPING SCREW 5X50 | | 2 | | | |
| 014 | 417777-4 | BAFFLE PLATE | | 1 | | | |
| 015 | 210005-4 | BALL BEARING 608DDW | | 1 | | | |
| 016 | 681644-1 | INSULATION WASHER | | 1 | | | |
| 017 | 513504-8 | ARMATURE ASS'Y 230-240V | | 1 | | | |
| D10 | | INC. 15,16,18 | | | | | |
| 018 | 240043-2 | FAN 70 | | 1 | | | |
| 019 | 253744-3 | FLAT WASHER 12 | | 1 | | | |
| 020 | 631482-1 | CONTROLLER | | 1 | | | |
| 021 | 651286-5 | SWITCH SGEL206C-5 | | 1 | * | | |
| 021-1 | 651286-5 | SWITCH SGEL206C-5 | O | 1 | | | |
| 022 | 645253-0 | NOISE SUPPRESSOR | | 1 | * | | |
| 022-1 | 645200-1 | NOISE SUPPRESSOR | S | 1 | | | |
| 023 | 265995-6 | TAPPING SCREW 4X18 | | 2 | | | |
| 024 | 687052-4 | STRAIN RELIEF | | 1 | | | |
| 025 | 682516-3 | CORD GUARD 9.3-85 | | 1 | * | | |
| 025-1 | 682504-0 | CORD GUARD 10-85 | O | 1 | | | |
| 026 | 665890-4 | POWER SUPPLY CORD 1.0-2-4.0 | | 1 | | | |
| 027 | 183419-9 | MOTOR HOUSING | | 1 | | | |
| D10 | | INC. 5 | | | | | |
| 028 | 853497-0 | NAME PLATE BO4900V | | 1 | | | |
| 029 | 317538-1 | FRAME | | 1 | | | |
| 030 | 211129-9 | BALL BEARING 6201DDW | | 1 | | | |
| 031 | 251291-8 | + SCREW M4X8 | | 2 | | | |
| 032 | 417773-2 | SCROLL COVER | | 1 | | | |
| 033 | 266042-6 | TAPPING SCREW BIND CT 4X20 | | 5 | | | |
| 034 | 443108-1 | FELT 6X225X3 | | 1 | | | |
| 035 | 266026-4 | TAPPING SCREW BIND CT 4X12 | | 2 | | | |
| 036 | 417772-4 | DUST GUIDE | | 1 | | | |
| 037 | 240051-3 | FAN 78 | | 1 | | | |
| 040 | 313104-2 | SLEEVE | | 1 | | | |
| 041 | 266058-1 | TAPPING SCREW CT 4X12 | | 3 | | | |
| 042 | 162171-2 | BEARING RETAINER 24 | | 1 | | | |
| | | | | | | | |

| | | | | | | |
|-------|----------|---------------------------------|---|---|---|--|
| 043 | 253315-6 | THIN WASHER 15 | | 1 | | |
| 044 | 211201-7 | BALL BEARING 6002LLB | | 1 | | |
| 045 | 211201-7 | BALL BEARING 6002LLB | | 1 | | |
| 046 | 213047-7 | O RING 4 | | 4 | | |
| 047 | 317535-7 | FOOT | | 4 | | |
| 048 | 213047-7 | O RING 4 | | 4 | | |
| 049 | 317537-3 | BASE | | 1 | | |
| 050 | 317536-5 | BALANCER | | 1 | | |
| 051 | 266071-9 | HEX. SOCKET HEAD BOLT M5X16 | | 1 | | |
| 052 | 345211-3 | UNDER COVER | | 1 | | |
| 053 | 213755-0 | O RING 75 | | 1 | | |
| 054 | 193521-0 | PAD | | 1 | | |
| 055 | 911118-1 | PAN HEAD SCREW M4X12 | | 8 | | |
| 056 | 266042-6 | TAPPING SCREW BIND CT 4X20 | | 2 | | |
| 057 | 253874-0 | FLAT WASHER 4 | | 2 | | |
| 058 | 257659-6 | SLEEVE 4 | | 2 | | |
| 059 | 153361-8 | CLAMP LEVER COMPLETE | | 2 | | |
| 060 | 153362-6 | PAPER CLAMP COMPLETE | | 2 | | |
| C10 | 421498-2 | CLAMP RUBBER | | 2 | | |
| A01 | 193294-5 | PAPER DUST BAG HOLDER | | 1 | | |
| A02 | 193293-7 | PAPER DUST BAG | | 1 | | |
| A03 | A-14093 | ABRASIVE PAPER 115-120 /STD | | 1 | | |
| F03 | 192349-3 | JOINT 25 | | 1 | | |
| A04 | 821550-0 | CONNECTOR PLASTIC CASE (TYP E2) | | 1 | * | |
| C10 | 453974-8 | LATCH | | 4 | * | |
| A04-1 | 821550-0 | CONNECTOR PLASTIC CASE (TYP E2) | < | 1 | | |
| C10 | 453974-8 | LATCH | | 4 | | |
| A05 | 837675-0 | INNER TRAY | | 1 | | |
| A06 | 800V58-9 | BO4900VJ INDICATION LABEL | | 1 | | |
| A07 | 800V59-7 | BO4900VJ PLASTIC CASE LABEL | | 2 | | |

Please state Parts No. when your order.

Print Date 27/12/2023