

Model No.DCS6401 ENGINE CHAIN SAW

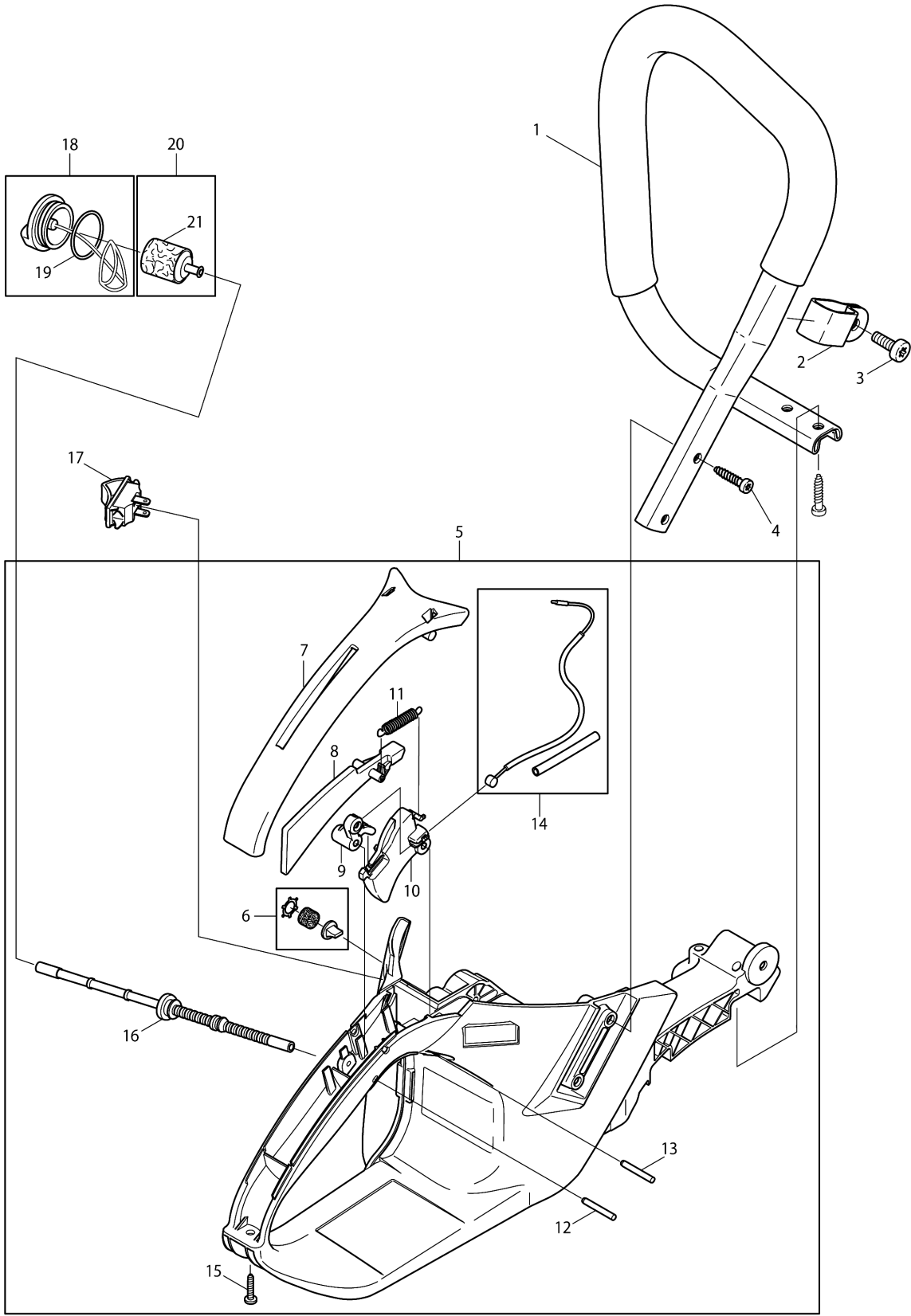

Model No.DCS6401 ENGINE CHAIN SAW

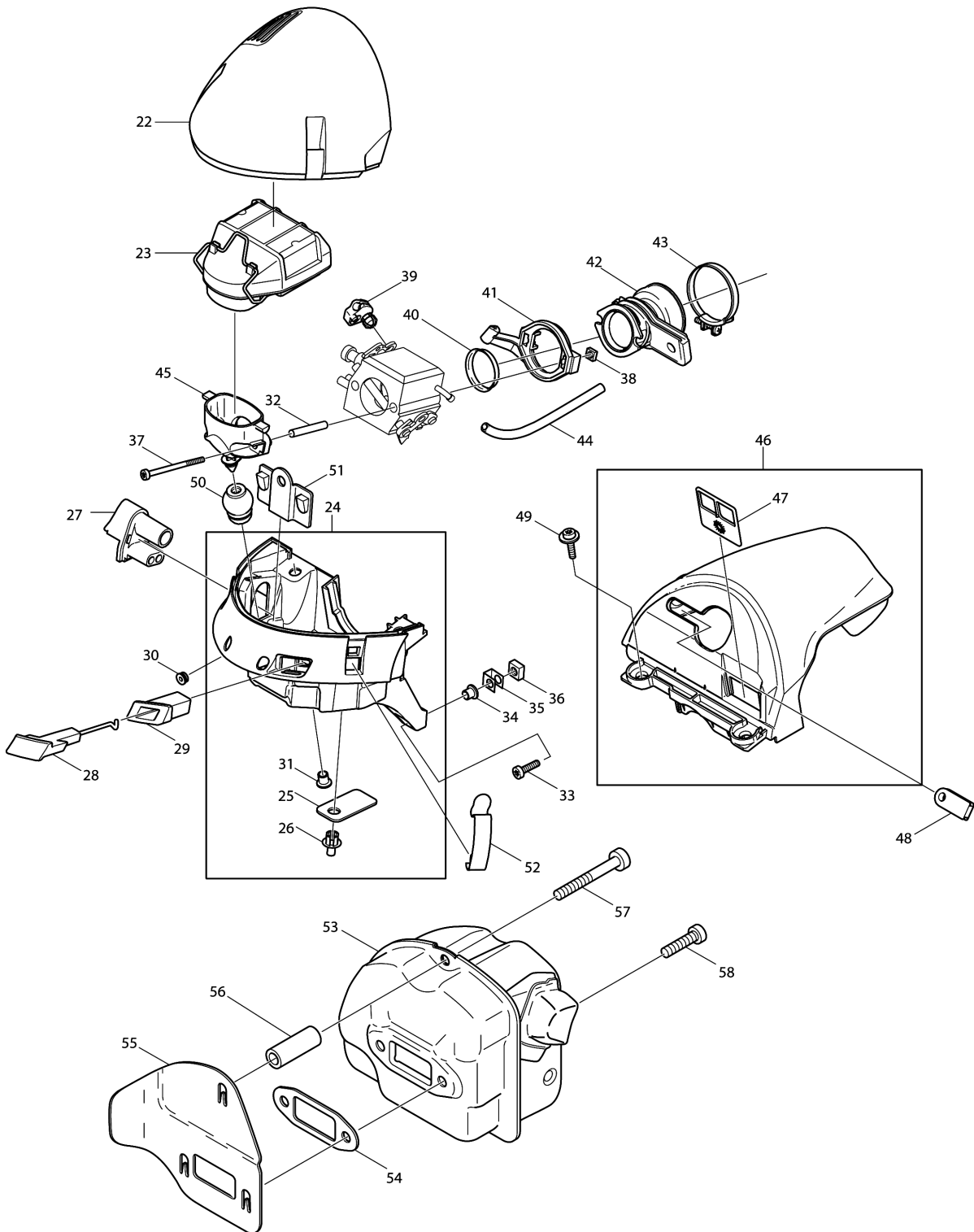

Model No.DCS6401 ENGINE CHAIN SAW

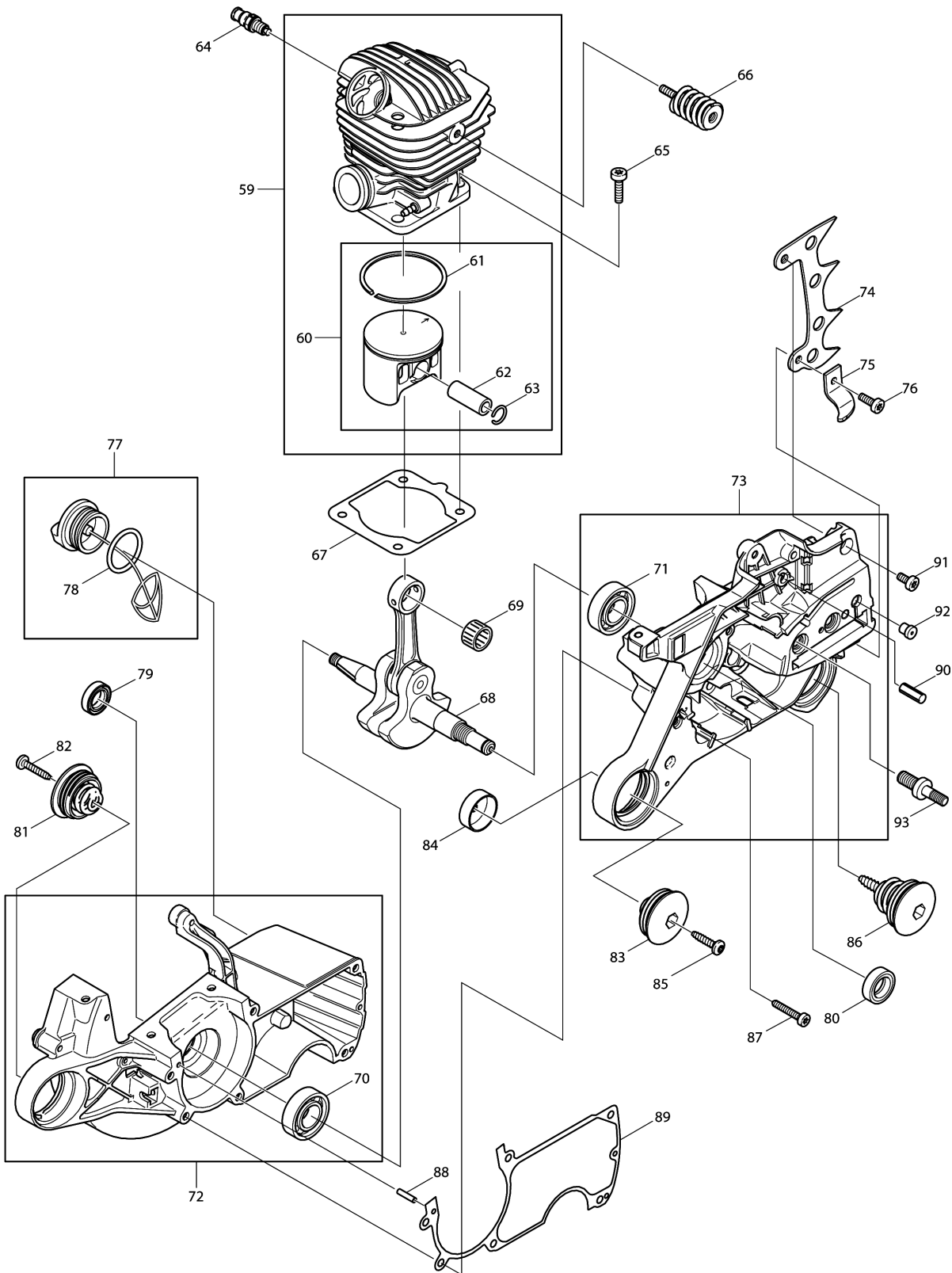

Model No.DCS6401 ENGINE CHAIN SAW

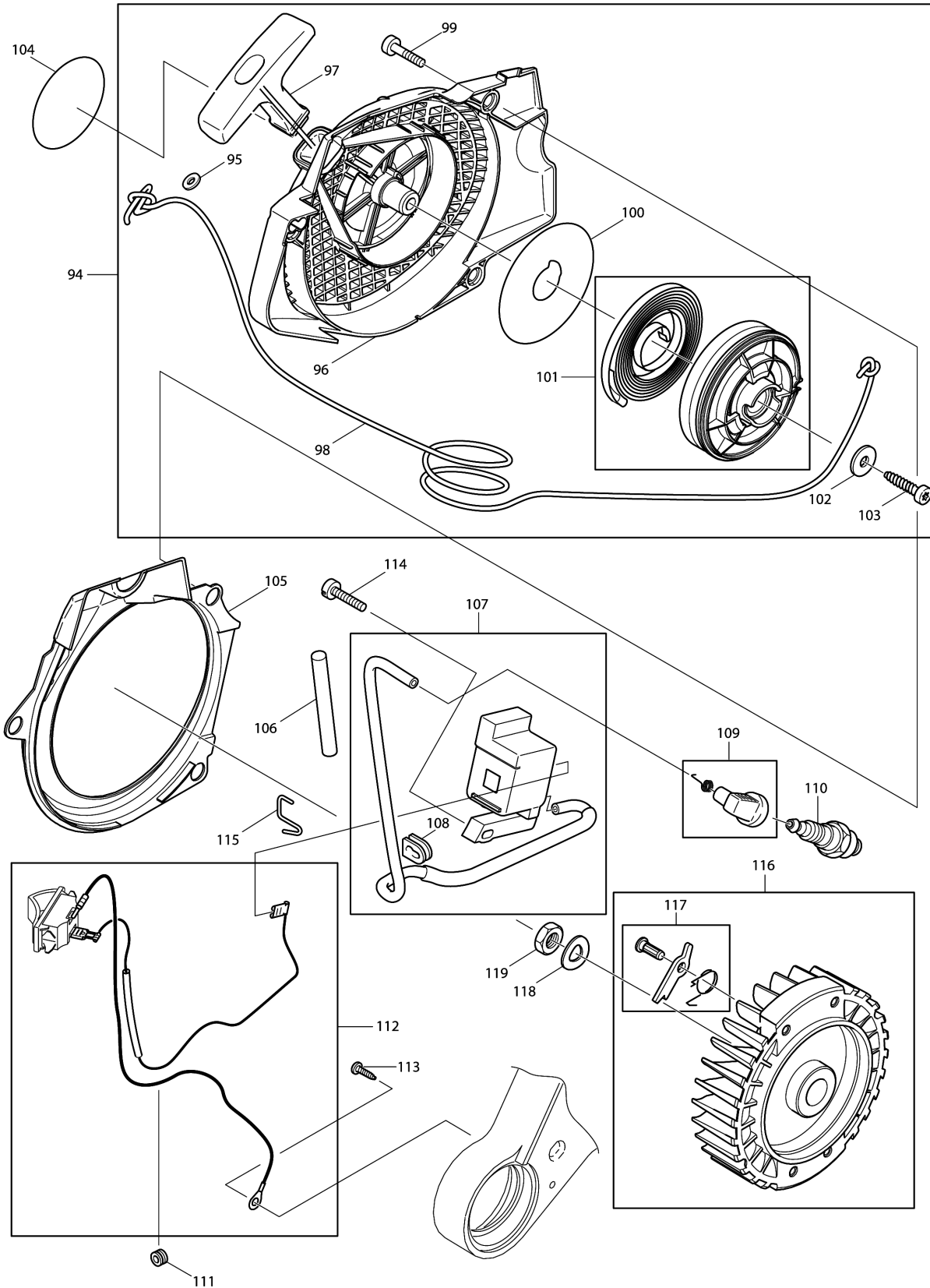

Model No.DCS6401 ENGINE CHAIN SAW

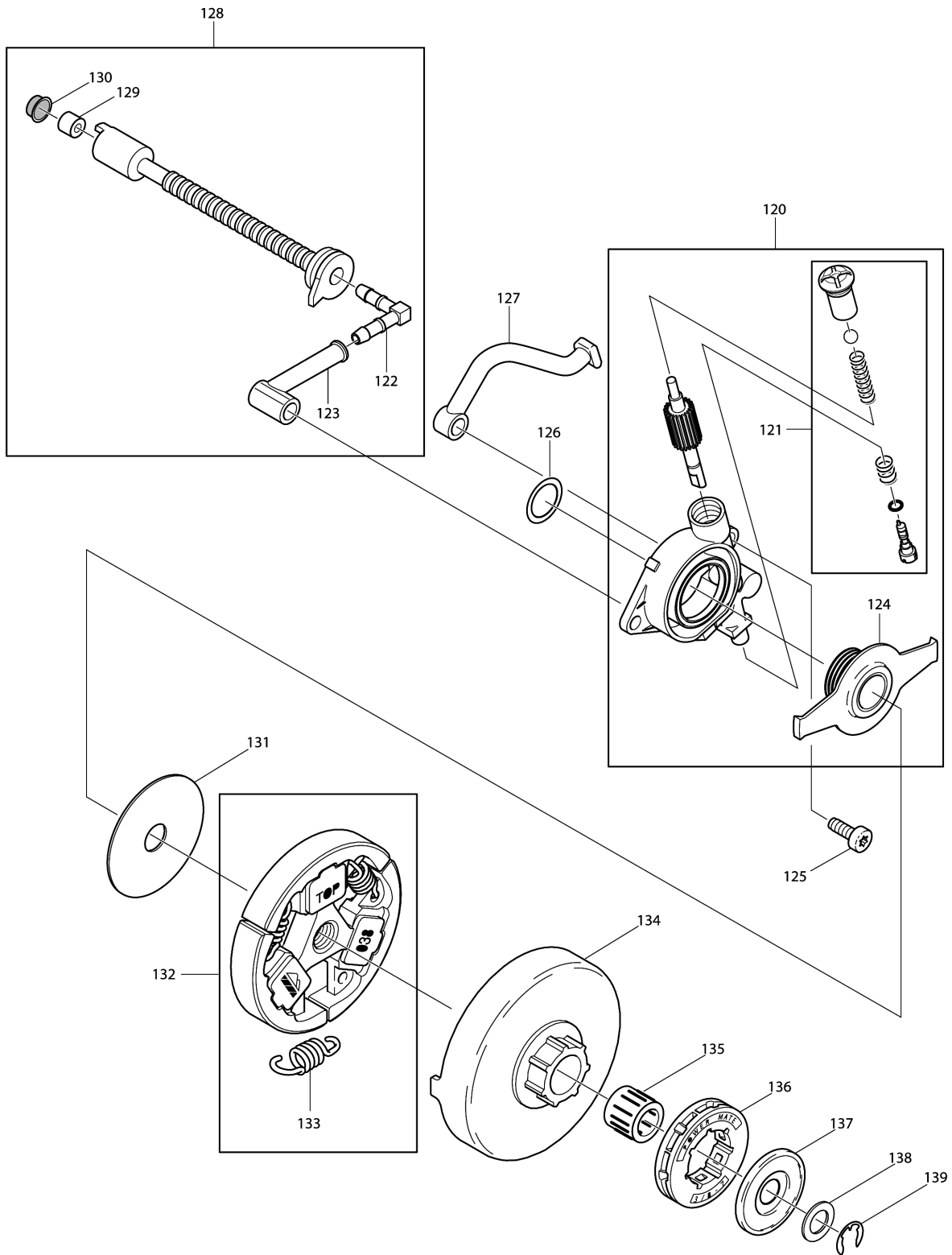

Model No.DCS6401 ENGINE CHAIN SAW

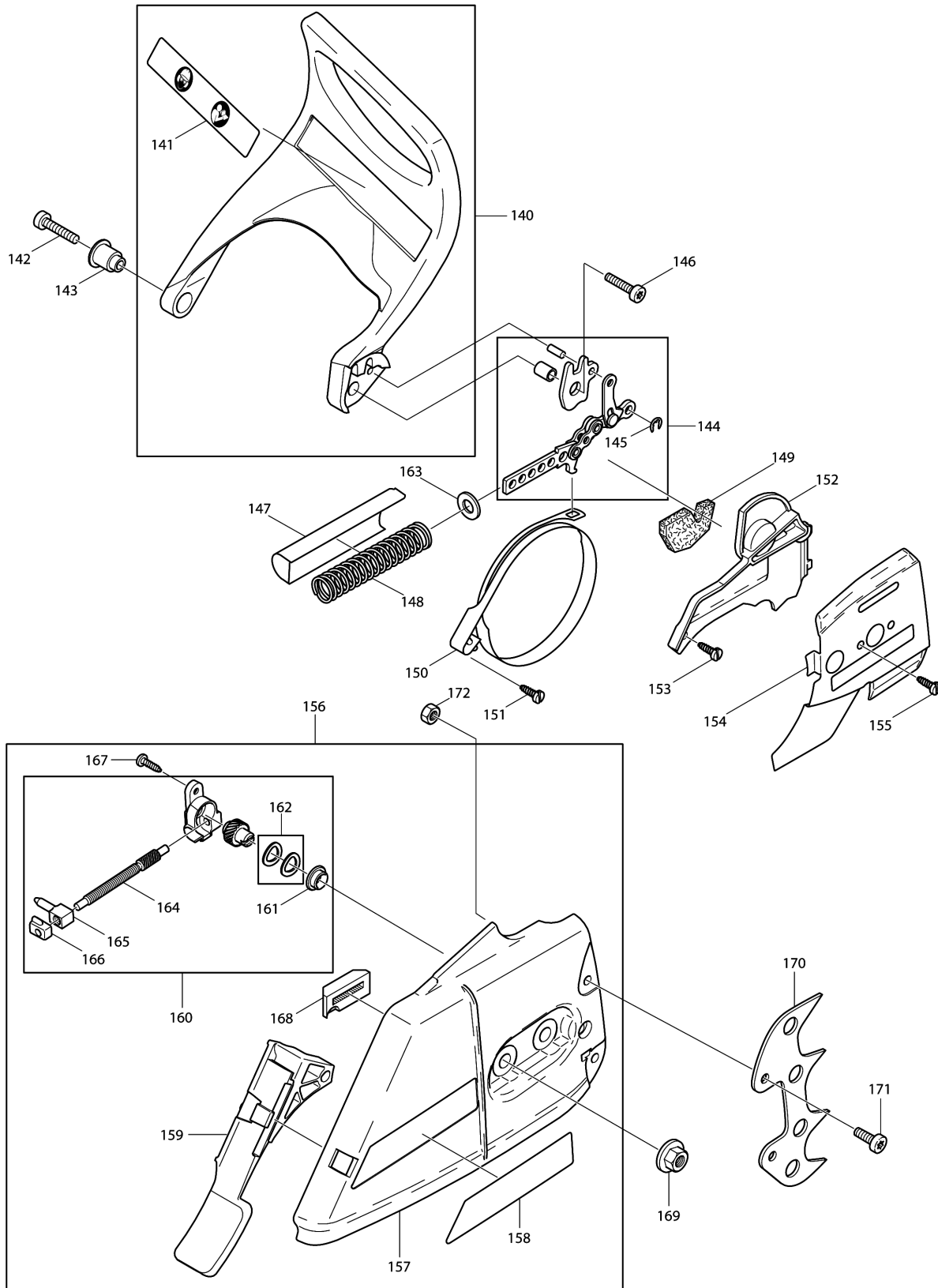

Model No.DCS6401 ENGINE CHAIN SAW

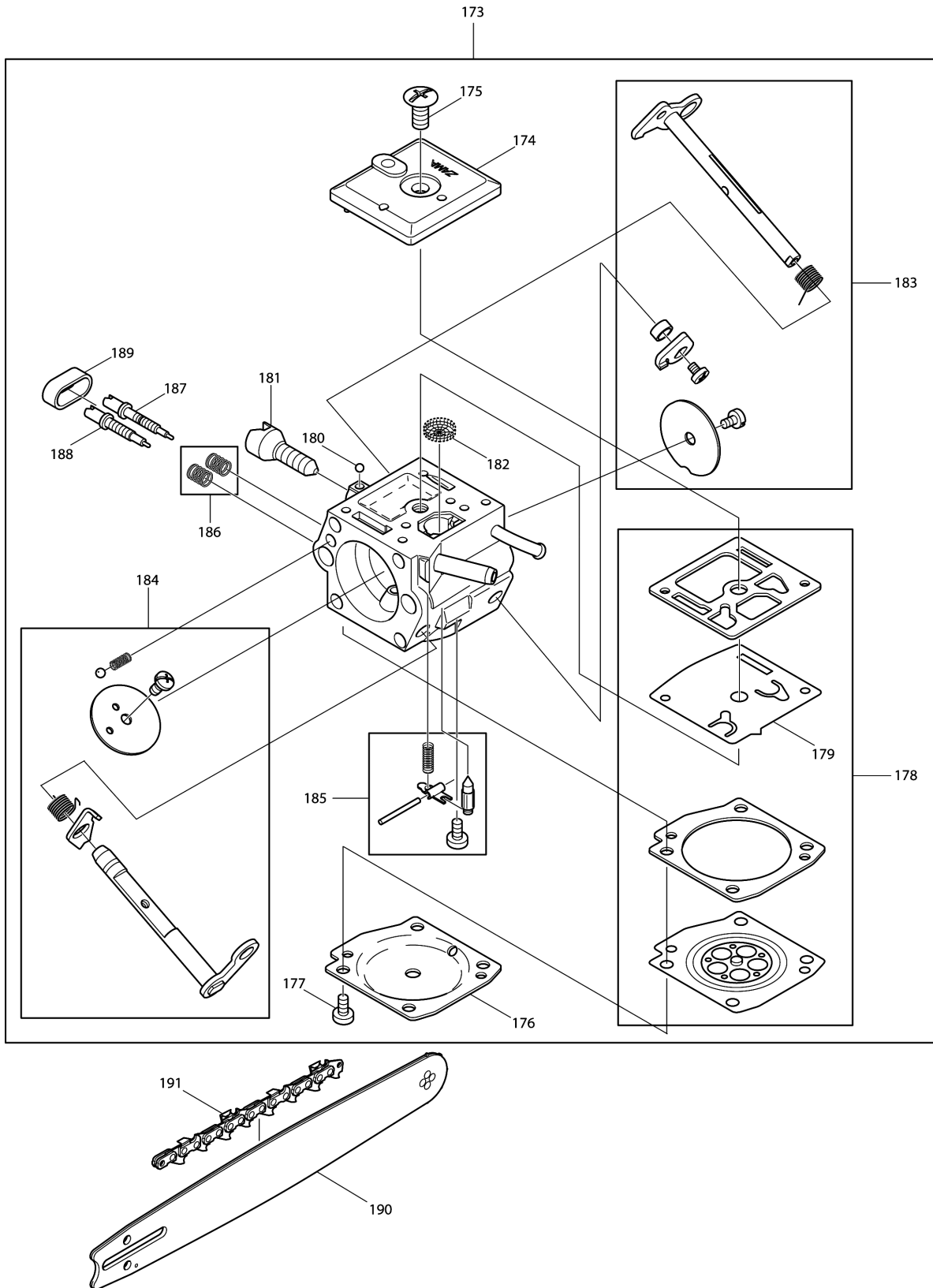

Model No.DCS6401 ENGINE CHAIN SAW

Item	Parts No.	Description	I/C	Qty	New/Old	Opt. 1	Opt. 2	Note
001	038310020	TUBULAR HANDLE ASSY.		1	*			
001-1	038310021	FRONT HANDLE ASSY	O	1	*			
001-2	140G06-9	TUBULAR HANDLE CPL.	O	1				
002	038310060	CLAMP		1				
003	908006145	H.L. SOCKET HEAD BOLT M6X14		1				
004	913455204	H.L.TAPPING SCREW 5.5X20		4	*			
004-1	913455204	H.L.TAPPING SCREW 5.5X20	O	4	*			
004-2	266475-5	H.L.TAPPING SCREW 5.5X20	O	4				
005	038114600	TANK CPL.		1				
D10		INC. 6-16						
006	957114060	AIR VALVE CPL.		1	*			
006-1	957114061	AIR VALVE CPL.	O	1				
007	038114630	GRIP PLATE		1				
008	038117020	CATCH LEVER		1				
009	038117030	ROCKER		1				
010	038117010	THROTTLE LEVER		1				
011	038117050	SPRING		1				
012	935930240	CYLINDRICAL PIN 3X24		1	*			
012-1	268233-5	PIN 3	O	1				
013	935930280	CYLINDRICAL PIN 3X28		1	*			
013-1	268335-7	PIN 3	O	1				
014	010117040	BOWDEN CABLE		1	*			
014-1	038117041	THROTTLE CONTROL CABLE	O	1				
015	913340204	H.L.SOCKET HEAD BOLT M4X20		1				
016	038114050	FUEL LINE		1				
017	975001210	SHORT CIRCUIT SWITCH		1				
018	010114050	TANK CAP ASSY		1				
D10		INC. 19						
019	963228030	O-RING 28		1				
020	963601130	SUCTION HEAD(FUEL)		1	*			
D10		INC. 21			*			
020-1	963601122	SUCTION HEAD(FUEL)	O	1	*			
D10		INC. 21			*			
020-2	010114010	SUCTION HEAD(FUEL)	O	1	*			
D10		INC. 21			*			
020-3	163499-1	SUCTION HEAD	O	1				
D10		INC. 21						
021	963601240	FELT		1				
022	038118620	COVER		1	*			
022-1	038118622	AIR FILTER ELEMENT COVER	O	1				
023	038173100	AIR FILTER CPL. FELT		1				
023A_	038173010	AIR FILTER CPL. NYLON		1				
024	038118630	BOTTOM		1				
D10		INC. 25,26,31						

Please order the parts with part number.

Print Date 14/11/2023

Model No.DCS6401 ENGINE CHAIN SAW

Item	Parts No.	Description	I/C	Qty	New/Old	Opt. 1	Opt. 2	Note
025	038118110	RUBBER FLAP		2				
026	938650062	RIVET		2				
027	038118080	ADJUSTING GUIDE		1				
028	038155050	CHOKE SHAFT		1	*			
028-1	038155052	CHOKE SHAFT	O	1				
029	038155020	CHOKE GUIDE		1				
030	965401020	RUBBER BUSH		1				
031	001118100	BUSHING		2	*			
031-1	326780-3	BUSH	O	2				
032	038155050	CHOKE SHAFT		2	*			
032-1	038155052	CHOKE SHAFT	O	2				
033	908005205	H.L. SOCKET HEAD BOLT M5X20		2	*			
033-1	266476-3	H.L. SOCKET HEAD BOLT M5X20	O	2				
034	001118100	BUSHING		2	*			
034-1	326780-3	BUSH	O	2				
035	038111050	CLIP		2				
036	038111060	SQUARE NUT M5		2	*			
036-1	264108-6	SQUARE NUT M5	O	2				
037	908204555	H.L. SOCKET HEAD BOLT M4X55		2	*			
037-1	266944-6	H.L. SOCKET HEAD BOLT M4X55	O	2				
038	921804004	SQUARE NUT M4		2				
039	038155010	RETAINING CLIP		1				
040	038131030	INSERT FOR SUCTION HOSE		1				
041	038171041	FLANGE		1				
042	038131010	SUCTION HOSE		1				
043	965603050	CARBURETOR INSULATOR CLAMP		1				
044	965452380	VENTILATION LINE		1	*			
044-1	965452382	OIL RESISTANT HOSE D=3MM L=1M	O	1				
045	038171010	CONNECTING MUFF		1				
046	038118690	HOOD CPL.		1				
047	038118140	ANTI ICING PLATE		1				
048	038118130	CABLE GUIDE		1	*			
048-1	424751-5	CABLE GUIDE	O	1				
049	917105205	H.L. SOCKET HEAD BOLT M5X20		2				
050	038171030	HOLDER		1				
051	038118100	PLUG		1				
052	038118071	STEEL CLIP		2				
053	038174200	MUFFLER ASSY		1				
054	965531130	GASKET		1	*			
054-1	965531131	GASKET	O	1	*			
054-2	038174811	MUFFLER GASKET	O	1				
055	038174020	COVER PLATE		1	*			

Please order the parts with part number.

Print Date 14/11/2023

Model No.DCS6401 ENGINE CHAIN SAW

Item	Parts No.	Description	I/C	Qty	New/Old	Opt. 1	Opt. 2	Note
055-1	038174023	HEAT INSULATION PLATE	O	1				
056	038174030	SLEEVE 5 L=26.8MM		1	*			
056-1	325939-9	CONNECTING LINK	O	1				
057	908305405	H.L. SOCKET HEAD BOLT M5X40		1	*			
057-1	266943-8	H.L. SOCKET HEAD BOLT M5X40	O	1				
058	908405205	H.L SOCKET HEAD BOLT M5X20		2	*			
058-1	266960-8	H.L. SOCKET HEAD BOLT M5X20	O	2				
059	040130030	CYLINDER/PISTON CPL.47MM DECO		1				
D10		INC. 60						
060	325132031	PISTON CPL.47MM		1				
D10		INC. 61-63						
061	325132050	PISTON RING 47MM		1	*			
061-1	257384-9	PISTON RING D47	O	1				
062	119132030	PISTON PIN		1	*			
062-1	257840-9	PISTON PIN	O	1				
063	119132060	CIRCLIP 12		2	*			
063-1	038132080	CIRCLIP 12	O	2	*			
063-2	234359-5	CIRCLIP 12	O	2				
064	001131150	DECOMPRESSION VALVE VERSION 1		1				
065	908005205	H.L. SOCKET HEAD BOLT M5X20		4	*			
065-1	266476-3	H.L. SOCKET HEAD BOLT M5X20	O	4				
066	038114150	SPRING WITH THREADED INSERT		1				
067	965531121	GASKET		1				
068	038120020	CRANKSHAFT CPL.		1	*			
068-1	144975-4	CRANKSHAFT CPL.	O	1				
069	962210019	NEEDLE CAGE		1	*			
069-1	962210121	NEEDLE CAGE	O	1	*			
069-2	212133-1	PISTON PIN BEARING 12X16X13	O	1				
070	960102159	BALL BAERING 6202		1				
071	960102179	BALL BEARING 6203		1				
072	038111630	CRANKCASE MAGNET SIDE		1	*			
D10		INC. 70			*			
072-1	038111660	CRANKCASE LEFT SIDE ASSY BLUE	O	1				
D10		INC. 70						
073	038111640	CRANKCASE CLUTCH SIDE		1				
D10		INC. 71						
074	038250020	SPIKE BAR		1				
075	038111080	CHAIN CATCH		1				
076	908005165	FILLISTER HEAD SCREW M5X16		1	*			
076-1	266605-8	H.L. SOCKET HEAD BOLT M5X16	O	1				

Please order the parts with part number.

Print Date 14/11/2023

Model No.DCS6401 ENGINE CHAIN SAW

Item	Parts No.	Description	I/C	Qty	New/Old	Opt. 1	Opt. 2	Note
077	010114050	TANK CAP ASSY		1				
D10		INC. 78						
078	963228030	O-RING 28		1				
079	962900052	OIL SEAL		1	*			
079-1	213814-0	RADIAL RING	O	1				
080	962900061	OIL SEAL		1				
081	038114130	SPRING CPL.WITH CAP		1				
082	913455204	H.L.TAPPING SCREW 5.5X20		1	*			
082-1	913455204	H.L.TAPPING SCREW 5.5X20	O	1	*			
082-2	266475-5	H.L.TAPPING SCREW 5.5X20	O	1				
083	038114130	SPRING CPL.WITH CAP		1				
084	038114190	POT		1	*			
084-1	038114191	POT	O	1				
085	913455204	H.L.TAPPING SCREW 5.5X20		1	*			
085-1	913455204	H.L.TAPPING SCREW 5.5X20	O	1	*			
085-2	266475-5	H.L.TAPPING SCREW 5.5X20	O	1				
086	038114140	SPRING CPL.WITH CAP		1	*			
086-1	038114141	SPRING CPL.WITH CAP	O	1				
087	908005305	H.L. SOCKET HEAD BOLT M5X30		6	*			
087-1	266945-4	H.L. SOCKET HEAD BOLT M5X30	O	6				
088	936430160	PIN 3X16		2	*			
088-1	258038-1	CLAMPING PIN	O	2				
089	038111042	GASKET		1	*			
089-1	038111043	CRANKCASE GASKET	O	1				
090	934660250	SPRING PIN 6X24		1				
091	908005125	H.L. SOCKET HEAD BOLT M5X12		1	*			
091-1	266946-2	H.L. SOCKET HEAD BOLT M5X12	O	1				
092	010245030	VENT VALVE		1	*			
092-1	168504-9	VENT VALVE	O	1				
093	038232010	BOLT		2				
094	038160600	STARTER ASSY.		1				
D10		INC. 95-103						
095	928405000	SPRING WASHER 5		1	*			
095-1	928405000	SPRING WASHER 5	O	1	*			
095-2	267821-5	SPRING WASHER 5	O	1				
096	038112630	FAN HOUSING		1				
097	001161010	STARTER GRIP		1	*			
097-1	001161020	STARTER GRIP	O	1				
098	108164020	STARTER ROPE 3.5MM (L=0.98M)		1				
098A_	985000155	STARTER ROPE 3.5MM L=100M		1				
099	908605205	H.L. SOCKET HEAD BOLT M5X20		3	*			
099-1	266942-0	H.L. SOCKET HEAD BOLT M5X20	O	3				

Please order the parts with part number.

Print Date 14/11/2023

Model No.DCS6401 ENGINE CHAIN SAW

Item	Parts No.	Description	I/C	Qty	New/Old	Opt. 1	Opt. 2	Note
100	038162050	SPACER		1				
101	038162021	CABLE DRUM CPL.		1				
102	924605510	WASHER 5.5/18X1.6		1				
103	913455204	H.L.TAPPING SCREW 5.5X20		1	*			
103-1	913455204	H.L.TAPPING SCREW 5.5X20	O	1	*			
103-2	266475-5	H.L.TAPPING SCREW 5.5X20	O	1				
104	908114835	LABEL DCS6401		1				
105	038112020	AIR DUCT		1				
106	970502110	INSULATING TUBE 6 L=1M		1	*			
106-1	970502120	INSULATING TUBE	O	1				
107	038143020	IGNITION COIL(BLACK)		1	*			
D10		INC. 108			*			
107-1	010038143	IGNITION COIL & FLYWHEEL SET	O	1	*			
D10		INC. 108			*			
107-2	010038143	IGNITION COIL & FLYWHEEL SET	O	1				
D10		INC. 108,116						
108	038143030	GROMMET		1				
109	957604240	SPARK PLUG CAP CPL.		1				
110	965603021	SPARK PLUG BPMR7A		1	*			
110-1	168648-5	SPARK PLUG (BPMR7A)	O	1				
111	965401011	GROMMET		1				
112	970311540	EARTH CABLE		1	*			
112-1	957311590	EARTH SET	O	1				
113	915135100	TAPPING SCREW 3.5X9.5		1	*			
113-1	266150-3	TAPPING SCREW BT 3.5X9.5	O	1				
114	908304205	H.L. SOCKET HEAD BOLT M4X20		2				
115	038111110	CLIP		2				
116	038141000	FLYWHEEL ASSY.		1				
D10		INC. 117						
117	108166051	STARTER RATCHET SET(2PCS EACH)		2				
118	926208001	SPRING WASHER 8		1	*			
118-1	267822-3	SPRING WASHER 8	O	1				
119	920208024	HEX. NUT M8X1(FINE THREAD)		1	*			
119-1	264107-8	HEXAGONAL NUT M8	O	1				
120	038245010	OIL PUMP CPL.		1	*			
D10		INC. 121,124			*			
120-1	038245011	OIL PUMP CPL.	O	1				
D10		INC. 121,124						
121	030245070	OIL PUMP REPAIR SET		1				
122	001245140	ANGULAR NIPPLE		1				
123	038245110	OIL LINE		1				
124	038245030	PUMP DRIVE		1				
125	908005125	H.L. SOCKET HEAD BOLT M5X12		2	*			

Please order the parts with part number.

Print Date 14/11/2023

Model No.DCS6401 ENGINE CHAIN SAW

Item	Parts No.	Description	I/C	Qty	New/Old	Opt. 1	Opt. 2	Note
125-1	266946-2	H.L. SOCKET HEAD BOLT M5X12	O	2				
126	038224020	DISC		1	*			
126-1	038224021	WASHER	O	1				
127	038245060	OIL LINE		1	*			
127-1	038245061	OIL LINE	O	1				
128	038245020	SUCTION LINE OIL CPL.		1				
D10		INC. 122,123,129,130						
129	900005066	WEIGHT RING		1				
130	963601100	SCREEN		1				
131	001182041	GUIDE DISC		1	*			
131-1	267389-1	FLAT WASHER 12	O	1				
132	038180010	CLUTCH ASSY.		1	*			
132-1	038180012	CLUTCH ASSY.	O	1	*			
132-2	127671-9	CLUTCH ASSEMBLY	O	1				
133	024184021	TENSION SPRING		3	*			
D10		INC. 140			*			
133-1	181184020	TENSION SPRING	O	3	*			
D10		INC. 140			*			
133-2	232352-3	TENSION SPRING 6	O	3				
D10		INC. 140						
134	038223020	CLUTCH DRUM CPL.		1				
135	962210024	NEEDLE CAGE 10/16X12		1				
136	119224070	RIM SPROCKET 3/8" SD7-7		1				
137	001224011	DISC		1				
138	021224010	SHIM		1	*			
138-1	021224011	WASHER 10	O	1				
139	927408000	STOP RING E-8		1	*			
139-1	259045-7	STOP RING E-8	O	1				
140	038213220	HAND GUARD CPL.		1				
D10		INC. 141						
141	980114237	LABEL		1				
142	908405205	H.L. SOCKET HEAD BOLT M5X20		1	*			
142-1	266960-8	H.L. SOCKET HEAD BOLT M5X20	O	1				
143	038213160	BUSHING		1				
144	957213030	BRAKE LINK PLATE COMPLETE		1				
D10		INC. 145						
145	927304000	STOP RING E-4		1	*			
145-1	257934-0	STOP RING E-4	O	1				
146	908005206	SCREW 5X20		1				
147	038213150	POT		1	*			
147-1	038213152	POT	O	1				
148	038213130	SPRING		1				
149	038213200	FORM SPONGE		1				
150	038213010	BRAKE SPRING		1				

Please order the parts with part number.

Print Date 14/11/2023

Model No.DCS6401 ENGINE CHAIN SAW

Item	Parts No.	Description	I/C	Qty	New/Old	Opt. 1	Opt. 2	Note
151	915135100	TAPPING SCREW 3.5X9.5		1	*			
151-1	266150-3	TAPPING SCREW BT 3.5X9.5	O	1				
152	038213040	PLATE		1				
153	915135100	TAPPING SCREW 3.5X9.5		1	*			
153-1	266150-3	TAPPING SCREW BT 3.5X9.5	O	1				
154	038111030	GUIDE PLATE		1				
155	915135100	TAPPING SCREW 3.5X9.5		1	*			
155-1	266150-3	TAPPING SCREW BT 3.5X9.5	O	1				
156	038213600	SPROCKET GUARD CPL.		1				
D10		INC. 157-160,167,168						
157	038213635	SPROCKET GUARD BLUE		1				
158	980114784	MAKITA LABEL		1				
159	038213190	CHIP GUIDE		1				
160	957213020	CHAIN TENSIONER CPL.		1				
D10		INC. 162,164-166						
161	038213080	BUSHING		1				
162	038213210	SPRING WASHER		2				
163	028213010	WASHER 12X9		1	*			
163-1	028213012	WASHER 12X9	O	1				
164	038213120	TENSIONING SCREW 12X9		1				
165	038213090	TENSIONING NUT		1				
166	038213070	CHAIN TENSIONER BEARING		1				
167	915135100	TAPPING SCREW 3.5X9.5		1	*			
167-1	266150-3	TAPPING SCREW BT 3.5X9.5	O	1				
168	024213240	CHAIN GUIDE		1				
169	923208004	HEX. FLANGE NUT M8(BAR NUT)		2	*			
169-1	252145-2	COLLARED HEX NUT M8	O	2				
170	957250060	SPIKE BAR RIGHT SET		1				
171	908005125	H.L. SOCKET HEAD BOLT M5X12		2	*			
171-1	266946-2	H.L. SOCKET HEAD BOLT M5X12	O	2				
172	920405000	HEX. NUT M5		2	*			
172-1	252238-5	HEX. LOCK NUT M5-8	O	2				
173	038153010	CARBURETOR		1				
D10		INC. 174-178,180-189						
174	038153030	PUMP COVER		1				
175	038153360	SCREW		1				
176	038153040	DIAPHRAGM COVER		1				
177	001153020	SCREW		4				
178	038153060	SET DIAPHRAGM / GASKETS		1				
D10		INC. 179						
179	038153070	PUMP DIAPHRAGM TEFLON		1				
180	038153210	LOCKING BALL		1				
181	038153220	IDLE STOP SCREW		1				
182	028153180	SCREEN		1				

Please order the parts with part number.

Print Date 14/11/2023

Model No.DCS6401 ENGINE CHAIN SAW

Item	Parts No.	Description	I/C	Qty	New/Old	Opt. 1	Opt. 2	Note
183	957153060	KIT THROTTLE SHAFT		1				
184	957153050	KIT CHOKE SHAFT		1				
185	957153070	CONTROL PARTS		1				
186	038153260	SPRING		2				
187	038153230	IDLE ADJUSTMENT SCREW		1				
188	038153240	MAIN ADJUSTMENT SCREW		1				
189	038153270	RUBBER RING		1				
190	445038655	GUIDE BAR STD 15" 3/8" .058" M		1	*			
190-1	162A69-9	GUIDE BAR 15	O	1				
190A_	445045655	GUIDE BAR STD 18" 3/8" .058" M		1	*			
190A1	162A60-7	GUIDE BAR 18	O	1				
190B_	445050655	GUIDE BAR STD 20" 3/8" .058" M		1	*			
190B1	162A88-5	GUIDE BAR 20	O	1				
190C_	445060655	GUIDE BAR STD 24" 3/8" .058" M		1	*			
190C1	162B05-1	GUIDE BAR 24	O	1				
191	528099660	SAW CHAIN 3/8" .058" L60 FC M		1				
191A_	528099668	SAW CHAIN 3/8" .058" L68 FC M		1				
191B_	528099672	SAW CHAIN 3/8 .058 L72 FC M		1				
191C_	528099683	SAW CHAIN 24"		1				
A01	952100643	CHAIN PROT. COVER 15"-18"		1	*			
A01-1	952020650	BAR COVER 18-20" 45-50CM MAKITA	O	1				
A01A_	952100653	CHAIN PROT. COVER 21"-24"		1	*			
A01A1	952020660	BAR COVER 21-24" 53-60CM MAKITA	O	1				
A02	940827000	HEXALOBULAR ANGLED DRIVER T27		1	*			
A02-1	782025-3	TORX WRENCH	O	1				
A03	941719131	UNIVERSAL WRENCH		1	*			
A03-1	941719133	UNIVERSAL WRENCH 13/19	O	1	*			
A03-2	782033-4	UNIVERSAL WRENCH 13/19	O	1				
A04	944340001	SCREW DRIVER		1	*			
A04-1	783012-5	SCREWDRIVER	O	1				
A05	950004001	PLASTIC BAG		1				

Please order the parts with part number.

Print Date 14/11/2023