

Model No.DHS660 165MM CORDLESS CIRCULAR SAW

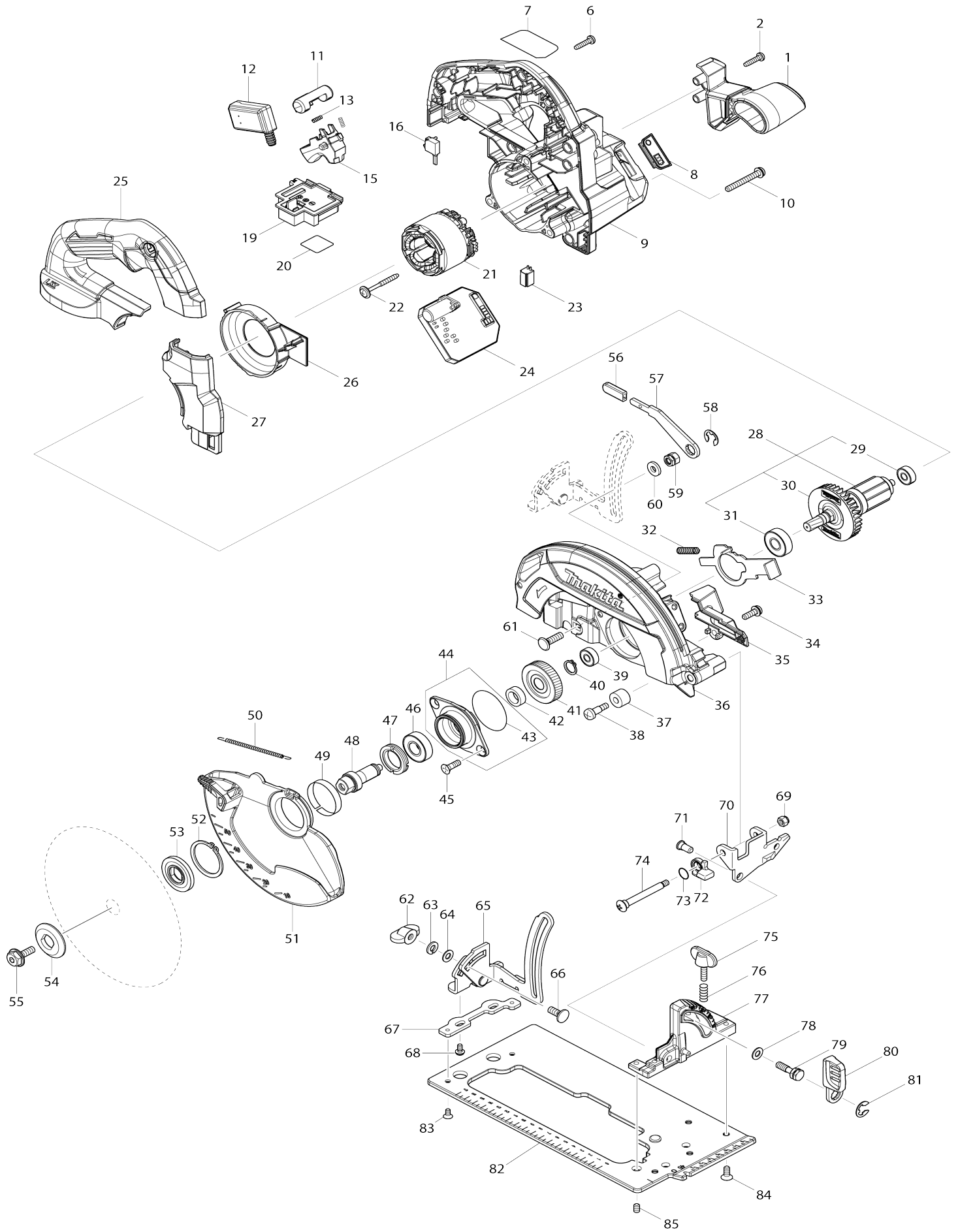

Model No.DHS660 165MM CORDLESS CIRCULAR SAW

Item No.	Parts No.	Description	Interchangeability	Q'ty	New/Old	Note1	Note2
001	458590-1	FRONT GRIP		1			
002	265995-6	TAPPING SCREW 4X18		1			
006	265995-6	TAPPING SCREW 4X18		7			
007	854N75-3	DHS660 NAME PLATE		1			
008	144251-6	INDICATION PLATE COMPLETE		1			
009	140C48-9	MOTOR HOUSING COMPLETE		1			
C10	263005-3	RUBBER PIN 6		2			
010	911263-2	PAN HEAD SCREW M5X40		3			
011	419704-7	LOCK OFF BUTTON		1			
012	651083-9	SWITCH C3XA-1PSPM		1			
013	231433-0	COMPRESSION SPRING 4		2			
015	458594-3	SWITCH LEVER		1			
016	632L80-6	SWITCH UNIT		1			
019	644809-6	TERMINAL		1			
020	854N80-0	DHS660 SERIAL NO. LABEL		1			
021	629362-3	STATOR		1	*		
021-1	629B61-9	STATOR	S	1			
022	251517-8	TAPPING SCREW 4X40		2			
023	620936-3	LED CIRCUIT		1			
024	620935-5	CONTROLLER		1	*		
024-1	620A72-1	CONTROLLER	<	1	*		
024-2	620K98-3	CONTROLLER	S	1			
025	458584-6	HANDLE COVER		1			
026	458586-2	BAFFLE PLATE		1			
027	458592-7	COVER		1			
028	519527-4	ROTOR ASS'Y		1			
D10		INC. 29-31					
029	211012-0	BALL BEARING 606ZZ		1			
030	240045-8	FAN 55		1			
031	210059-1	BALL BEARING 6000DDW		1			
032	233117-6	COMPRESSION SPRING 6		1	*		
032-1	233342-9	COMPRESSION SPRING 6	<	1			
033	347400-6	SHAFT LOCK		1			
034	911223-4	PAN HEAD SCREW M5X16		1			
035	458589-6	DUCT		1			
036	140D07-9	BLADE CASE COMPLETE		1			
C10	213821-3	O-RING 26		1			
037	262511-5	RUBBER SLEEVE 6		1			
038	265115-2	+ PAN HEAD SCREW M5		1			
039	211012-0	BALL BEARING 606ZZ		1			
040	961052-5	RETAINING RING (EXT) S-12		1			
041	226192-9	HELICAL GEAR 49		1			
042	257173-2	RING 12		1			
043	213512-6	O RING 39		1			
044	135993-3	BEARING BOX ASSEMBLY		1			
D10		INC. 43					
045	265034-2	+ COUNTERSUNK HEAD SCREW M5X16		2			

046	211131-2	BALL BEARING 6001DDW		1		
047	285843-3	BEARING RETAINER 19-29		1		
048	327143-6	SPINDLE		1	*	
048-1	327244-0	SPINDLE	<	1		
049	345469-4	THICKNESS RING		1		
050	231832-6	TENSION SPRING 3		1		
051	458680-0	SAFETY COVER		1		
052	961152-1	RETAINING RING (EXT) S-34		1		
053	224593-5	INNER FLANGE 35		1		
054	224409-4	OUTER FLANGE 35		1		
055	266925-0	HEX.SOCKET HEX.BOLT M6X18		1		
056	286036-5	CAP		1		
057	347399-5	LEVER PLATE		1		
058	257982-9	BOW STOP RING E-8		1		
059	264096-7	HEX. NUT M6		1	*	
059-1	252265-2	HEX. NUT M6	S	1		
060	267118-2	FLAT WASHER 6		1	*	
061	266737-1	FLAT HEAD SQ. NECK BOLT M6X20		1		
062	252631-3	THUMB NUT M6		1		
063	942151-2	SPRING WASHER 6		1	*	
063-1	253428-3	SPRING WASHER 6	O	1	*	
064	941151-9	FLAT WASHER 6		1		
065	161899-9	DEPTH GUIDE COMPLETE		1		
066	265939-6	FLAT HEAD SQ. NECK BOLT M6X14		1		
067	347401-4	REAR GUIDE PLATE		1		
068	265648-7	PAN HEAD SCREW M4X8		2		
069	252103-8	HEX. LOCK NUT M5-8		1		
070	345590-9	ANGULAR GUIDE		1		
071	256480-0	SHOULDER PIN 6-7		1		
072	318823-5	STOPPER		1		
073	213977-2	O RING 7		1		
074	266734-7	+ TRUSS HEAD SCREW M5		1		
075	251896-4	SCREW M5X20		1		
076	231007-7	COMPRESSION SPRING 6		1		
077	319715-1	ANGULAR PLATE		1		
078	941151-9	FLAT WASHER 6		1	*	
079	266735-5	HEX.BOLT M6X20		1	*	
079-1	265B21-3	HEX.BOLT M6X20	S	1		
080	271446-9	LEVER 45		1		
081	257982-9	BOW STOP RING E-8		1		
082	347398-7	BASE		1		
083	265085-5	+ COUNTERSUNK HEAD SCREW M4X8		2		
084	912212-2	COUNTERSUNK HEAD SCREW M5 X12		4		
085	266436-5	H.S.SET SCREW(FLAT POINT)M5X8		3		
086	620K37-3	CONTROLLER B	S	1		
087	652119-7	PAN HEAD SCREW M2X6	S	6		
A01	783203-8	HEX. WRENCH 5		1		
A02	B-62979	TCT BLADE165X25T WOOD EFFIC		1		

		UT				
A03	164095-8	GUIDE RULE		1		
A04	199230-9	DUST NOZZLE SET		1		
C10	911233-1	PAN HEAD SCREW M5X20		1		
F01	199140-0	GUIDE RAIL 1000 SET		1		
F02	194367-7	GUIDE RAIL 3000 SET		1		
F03	194368-5	GUIDE RAIL 1400 SET		1		
F05	194416-0	SHEET 10000 SET		1		
F06	194417-8	RUBBER SHEET 10000 SET		1		
F07	194418-6	POSITION SHEET 1400 SET		1		
F09	194910-2	POSITION SHEET 1900 SET		1		
F11	194925-9	GUIDE RAIL 1900 SET		1		
F13	196664-7	BEVEL GUIDE SET		1	*	
F15	199231-7	HOOK SET		1		
F16	199232-5	GUIDE RAIL ADAPTER I SET		1		
A05	817N16-0	DHS660RTJ INDICATION LABEL		1		
A06	817N17-8	DHS660RTJ PLASTIC CASE LABEL		2		
A07	821551-8	CONNECTOR PLASTIC CASE (TYP E3)		1		
C10	453974-8	LATCH		4		
A08	839752-4	INNER TRAY		1		
A09	450128-8	BATTERY COVER		1		
A10	***DC18RC	DC18RC FAST CHARGER		1		
D10		COMPO-PARTS				
A11	197280-8	BATTERY BL1850B SET		2	*	
A11-1	197280-8	BATTERY BL1850B SET	0	2		
A05	197280-8	BATTERY BL1850B SET		1		

Please state Parts No. when your order.

Print Date 24/10/2023