

# Model No.DHS710 190MM CORDLESS CIRCULAR SAW

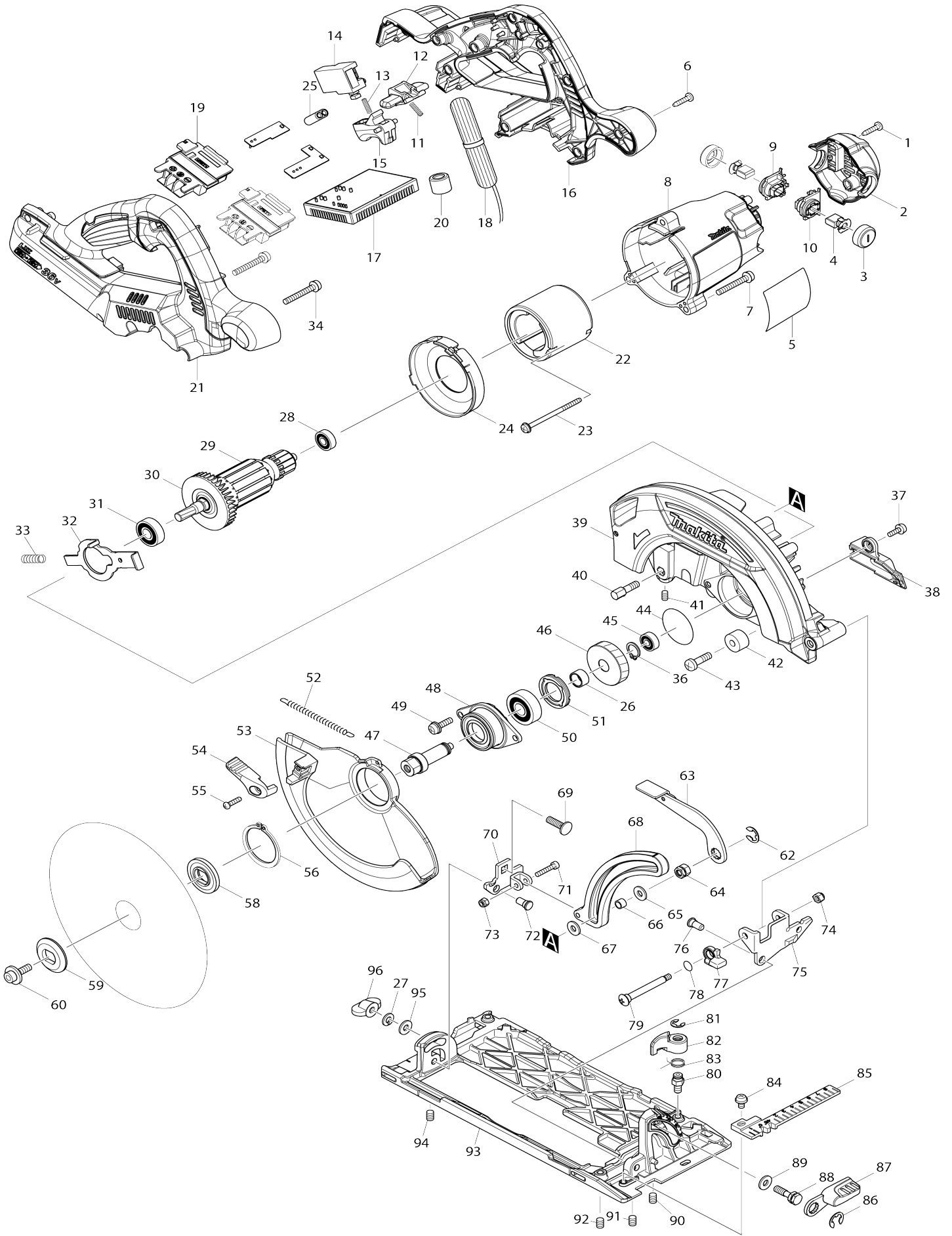

Model No.DHS710 190MM CORDLESS CIRCULAR SAW

Item No.	Parts No.	Description	Interchangeability	Q'ty	New/Old	Note1	Note2
001	266326-2	TAPPING SCREW 4X18		2			
002	454697-1	REAR COVER		1			
003	643829-7	HOLDER CAP		2			
004	194928-3	CARBON BRUSH CB-442		1			
005	814Y56-5	DHS710 NAME PLATE		1			
006	266326-2	TAPPING SCREW 4X18		9			
007	911258-5	PAN HEAD SCREW M5X35		3			
008	454693-9	MOTOR HOUSING		1			
009	644503-0	BRUSH HOLDER		1			
010	644504-8	BRUSH HOLDER		1			
011	231469-9	COMPRESSION SPRING 4		1			
012	419664-3	LOCK OFF LEVER		1			
013	231469-9	COMPRESSION SPRING 4		1			
014	650730-9	SWITCH TG72BD-6		1			
015	419665-1	SWITCH LEVER		1			
016	187768-6	HANDLE SET		1			
C10	263005-3	RUBBER PIN 6		4			
C20	802G93-3	INDICATION LABEL		1			
D10		INC. 21					
017	620254-9	CONTROLLER		1	*		
017-1	620305-8	CONTROLLER	<	1	*		
017-2	620827-8	CONTROLLER	<	1			
018	632B66-0	LEAD UNIT		1			
019	643899-6	TERMINAL		2			
020	688163-8	LINE FILTER		1			
021	187768-6	HANDLE SET		1			
C10	263005-3	RUBBER PIN 6		4			
C20	802G93-3	INDICATION LABEL		1			
D10		INC. 16					
022	638571-3	YOKE UNIT		1	*		
022-1	632H52-7	YOKE UNIT	O	1	*		
022-2	638571-3	YOKE UNIT	O	1			
023	266292-3	TAPPING SCREW 4X65		2			
024	454696-3	BAFFLE PLATE		1			
025	688172-7	LINE FILTER		1			
026	257349-1	SLEEVE 12		1			
027	942151-2	SPRING WASHER 6		1	*		
027-1	253428-3	SPRING WASHER 6	O	1	*		
028	210017-7	BALL BEARING 607DDW		1			
029	519332-9	ARMATURE ASS'Y 36V		1			
D10		INC. 28,30,31					
030	240045-8	FAN 55		1			
031	210059-1	BALL BEARING 6000DDW		1			
032	344681-3	SHAFT LOCK		1			
033	233117-6	COMPRESSION SPRING 6		1			
034	911258-5	PAN HEAD SCREW M5X35		2			
036	961052-5	RETAINING RING (EXT) S-12		1			

037	911223-4	PAN HEAD SCREW M5X16		1		
038	453285-1	DUCT		1		
039	142365-5	BLADE CASE COMPLETE		1		
C10	213434-0	O RING 26		1		
040	265594-4	HEX.BOLT M6X18		1		
041	266229-0	H.S.SET SCREW(CUP POINT)M5X8		1		
042	262552-1	RUBBER SLEEVE 6		1	*	
042-1	262502-6	RUBBER SLEEVE 6	O	1		
043	251247-1	+ PAN HEAD SCREW M6X20		1		
044	213512-6	O RING 39		1		
045	210028-2	BALL BEARING 606ZZ		1		
046	227786-3	HELICAL GEAR 49		1		
047	326357-4	SPINDLE		1		
048	319088-2	BEARING BOX		1		
049	911233-1	PAN HEAD SCREW M5X20		2		
050	211129-9	BALL BEARING 6201DDW		1	*	
050-1	210195-3	BALL BEARING 6201DDW	O	1		
051	285852-2	BEARING RETAINER 19-33		1		
052	231877-4	TENSION SPRING 4		1		
053	319072-7	SAFETY COVER		1		
054	272258-3	LEVER 37		1		
055	265178-8	PAN HEAD SCREW M4X16		1		
056	961155-5	RETAINING RING S-38		1		
058	224412-5	INNER FLANGE 35		1	*	
058-1	224473-5	INNER FLANGE 35	<	1	*	
058-2	224593-5	INNER FLANGE 35	<	1		
059	224409-4	OUTER FLANGE 35		1		
060	266308-4	HEX. SOCKET HEAD BOLT M6X20		1	*	
060-1	266925-0	HEX.SOCKET HEX.BOLT M6X18	O	1		
062	257982-9	BOW STOP RING E-8		1		
063	272279-5	LEVER PLATE		1		
064	264096-7	HEX. NUT M6		1		
065	267100-1	FLAT WASHER 6		1		
066	257669-3	SLEEVE 6		1		
067	267100-1	FLAT WASHER 6		1		
068	141312-3	DEPTH GUIDE COMPLETE		1		
069	251919-8	CAP SQUARE NECK BOLT M6X20		1		
070	165670-3	REAR ANGULAR GUIDE		1		
071	922137-2	HEX. SOCKET HEAD BOLT M4X20		1		
072	256480-0	SHOULDER PIN 6-7		1		
073	252126-6	HEX. LOCK NUT M4-7		1		
074	252103-8	HEX. LOCK NUT M5-8		1		
075	345590-9	ANGULAR GUIDE		1		
076	256480-0	SHOULDER PIN 6-7		1		
077	318823-5	STOPPER		1		
078	213062-1	O RING 9		1	*	
078-1	213977-2	O RING 7	<	1		
079	266734-7	+ TRUSS HEAD SCREW M5		1		
080	265571-6	HEX. BOLT M6X10		2		
081	961012-7	STOP RING E-6		2		
082	453165-1	LOCK LEVER		2		
083	233596-8	TORSION SPRING 11		2		

084	911203-0	PAN HEAD SCREW M5X8		1			
085	453286-9	TOP GUIDE		1			
086	257982-9	BOW STOP RING E-8		1			
087	272272-9	LEVER 45		1			
088	266735-5	HEX.BOLT M6X20		1	*		
088-1	265B21-3	HEX.BOLT M6X20	S	1			
089	941151-9	FLAT WASHER 6		1	*		
090	266208-8	H.S.SET SCREW(CUP POINT)M6X8		1			
091	266208-8	H.S.SET SCREW(CUP POINT)M6X8		1			
092	266208-8	H.S.SET SCREW(CUP POINT)M6X8		1			
093	318819-6	BASE		1			
094	266208-8	H.S.SET SCREW(CUP POINT)M6X8		1			
095	941151-9	FLAT WASHER 6		1			
096	252631-3	THUMB NUT M6		1			
A01	164095-8	GUIDE RULE		1			
A02	783217-7	HEX. WRENCH 5		1			
A03	B-02939	T.C.T. SAW BLADE 190MM		1			
A04	196520-1	DUST NOZZLE SET		1			
C10	911128-8	P.H.SCREW M4X16 WITH WR		1			
A05	821552-6	CONNECTOR PLASTIC CASE (TYP E4)		1	*		
C10	453974-8	LATCH		4	*		
A05-1	143074-9	CONNECTOR PLASTIC CASE (TYP E4)	<	1			
C10	453974-8	LATCH		4			
A06	837861-3	INNER TRAY		1			
A07	802H98-9	DHS710RF2J INDICATION LABEL		1			
A08	802H99-7	DHS710RF2J PLASTIC CASE LABEL		2			
A09	***DC18RC	DC18RC FAST CHARGER		1			
A10	194204-5	BATTERY BL1830 SET		2	*		
A10-1	194204-5	BATTERY BL1830 SET	O	2	*		
A10-2	197600-6	BATTERY BL1830B SET	<	2	*		
A10-3	197600-6	BATTERY BL1830B SET	O	2			
F04-3	197606-4	BATTERY BL1830B SET (2PIECES)	O	1			
F05-3	197600-6	BATTERY BL1830B SET	O	1			
F06-4	197599-5	BATTERY BL1830B SET	O	1			
F07-3	197267-0	BATTERY BL1840B SET	O	1			
F08-3	197267-0	BATTERY BL1840B SET	O	1			
F09-3	197265-4	BATTERY BL1840B SET	O	1			
F10-3	197265-4	BATTERY BL1840B SET	O	1			
F11-3	197273-5	BATTERY BL1840B SET(2PIECES)	O	1			
F12	194367-7	GUIDE RAIL 3000 SET		1			
F13	194368-5	GUIDE RAIL 1400 SET		1			
F15	194416-0	SHEET 10000 SET		1			
F16	194417-8	RUBBER SHEET 10000 SET		1			
F17	194418-6	POSITION SHEET 1400 SET		1			
F19	194910-2	POSITION SHEET 1900 SET		1			
F21	194925-9	GUIDE RAIL 1900 SET		1			
F24	196664-7	BEVEL GUIDE SET		1	*		
F25-1	197252-3	GUIDE RAIL ADAPTER SET	O	1			
F28	199140-0	GUIDE RAIL 1000 SET		1			

F29	199141-8	GUIDE RAIL 1500 SET		1		
-----	----------	---------------------	--	---	--	--

Please state Parts No. when your order.

Print Date 24/10/2023