

Model No.DHS900 235MM CORDLESS CIRCULAR SAW

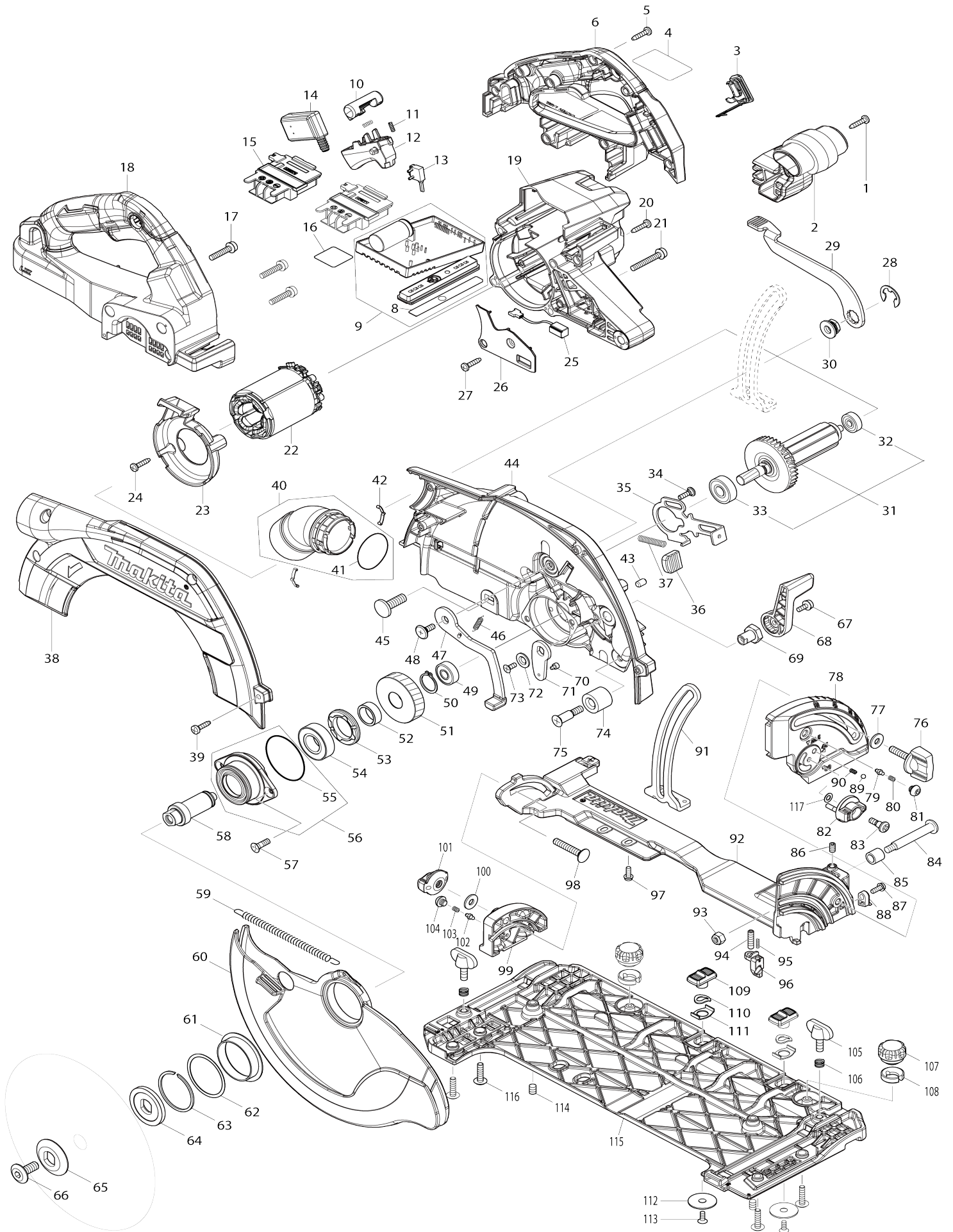

Model No.DHS900 235MM CORDLESS CIRCULAR SAW

Item No.	Parts No.	Description	Interchangeability	Q'ty	New/Old	Note1	Note2
001	266326-2	TAPPING SCREW 4X18		1			
002	459828-7	FRONT GRIP		1			
003	140F99-0	CAP COMPLETE		1			
C10	213218-6	O RING 16		1	*		
C11	213A05-9	O-RING16	O	1			
C20	818H07-8	CAP LABEL		1			
004	856L73-1	DHS900 NAME PLATE		1			
005	266326-2	TAPPING SCREW 4X18		8			
006	183N39-3	HANDLE SET		1			
C10	263005-3	RUBBER PIN 6		4			
D10		INC. 18					
008	813T74-0	INDICATION LABEL		1			
009	620C59-5	CONTROLLER COMPLETE		1	*		
D10		INC. 8					
009-1	620M35-9	CONTROLLER COMPLETE	S	1			
D10		INC. 8					
010	419704-7	LOCK OFF BUTTON		1			
011	231433-0	COMPRESSION SPRING 4		2			
012	459829-5	SWITCH LEVER		1			
013	632M92-5	SWITCH UNIT		1			
014	651083-9	SWITCH C3XA-1PSPM		1			
015	643874-2	TERMINAL		2			
016	856L79-9	DHS900 SERIAL NO. LABEL		1			
017	911243-8	PAN HEAD SCREW M5X25		3			
018	183N39-3	HANDLE SET		1			
C10	263005-3	RUBBER PIN 6		4			
D10		INC. 6					
019	459823-7	MOTOR HOUSING		1			
020	266326-2	TAPPING SCREW 4X18		1			
021	911258-5	PAN HEAD SCREW M5X35		4			
022	629462-9	STATOR		1	*		
022-1	629C15-2	STATOR	S	1			
023	459826-1	BAFFLE PLATE		1			
024	266326-2	TAPPING SCREW 4X18		2			
025	620936-3	LED CIRCUIT		1			
026	459827-9	LIGHT COVER		1			
027	266326-2	TAPPING SCREW 4X18		1			
028	257953-6	BOW STOP RING E-12		1			
029	271453-2	LEVER 132		1			
030	252262-8	COLLERED HEX. NUT M8		1			
031	519602-6	ROTOR ASS'Y		1			
D10		INC. 32,33					
032	210022-4	BALL BEARING 626DDW		1			
033	210059-1	BALL BEARING 600DDW		1			
034	251529-1	+ PAN HEAD SCREW M4X14		1			
035	347575-1	SHAFT LOCK		1			
036	286039-9	CAP		1			

037	233084-5	COMPRESSION SPRING 6		1		
038	319860-2	BLADE CASE COVER		1		
039	266034-5	TAPPING SCREW CT 4X16		4		
040	136173-4	DUST NOZZLE ASS'Y		1		
D10		INC. 41				
041	213444-7	O RING 30		1		
042	232227-6	LEAF SPRING		2	*	
042-1	232674-1	LEAF SPRING	O	2		
043	263005-3	RUBBER PIN 6		1	*	
043-1	263005-3	RUBBER PIN 6	S	1		
044	140P83-5	BLADE CASE COMPLETE		1	*	
C10	213434-0	O RING 26		1	*	
C20	8004T1-0	SCALE LABEL		1	*	
044-1	140P83-5	BLADE CASE COMPLETE	S	1		
C10	213434-0	O RING 26		1		
C20	8004T1-0	SCALE LABEL		1		
D10		INC. 43				
045	266396-1	FLATHEAD SQUARENECKBOLT M 8X24		1		
046	232563-0	TENSION SPRING 4		1		
047	162686-9	OPEN LEVER		1		
048	265A60-7	+ PAN HEAD SCREW M5X14		1		
049	210029-0	BALL BEARING 608ZZ		1		
050	961057-5	RETAINING RING S-17		1		
051	226934-1	HELICAL GEAR 46		1		
052	257451-0	RING 17		1		
053	285809-3	BEARING RETAINER 23-36		1		
054	210301-0	BALL BEARING 6003DDW		1		
055	213623-7	O RING 46		1		
056	136192-0	BEARING BOX ASS'Y		1		
D10		INC. 55				
057	265034-2	+ COUNTERSUNK HEAD SCREW M5X16		2	*	
057-1	265D49-3	+COUNTERSUNK HEAD SCREW M 5X16	O	2		
058	327192-3	SPINDLE		1		
059	232562-2	TENSION SPRING 6		1		
060	319861-0	SAFETY COVER		1		
061	459830-0	SPACER		1		
062	267337-0	FLAT WASHER 40		1		
063	257452-8	RETAINING RING (EXT) WR-40		1		
064	224360-8	INNER FLANGE 40		1		
065	224600-4	OUTER FLANGE 38		1		
066	265A59-2	HEX.SOCKET HEAD BOLT M8		1		
067	911113-1	PAN HEAD SCREW M4X10 WITH WR		1		
068	271451-6	LEVER 55		1		
069	252275-9	HEX. NUT M4-16		1		
070	265A82-7	HEX. SOCKET HEAD SCREW M3X4		1		
071	347576-9	OPEN PLATE		1		
072	347577-7	WASHER 6		1		
073	265135-6	+ COUNTERSUNK HEAD SCREW M4X10		1		

074	262185-2	RUBBER SLEEVE8		1		
075	251572-0	+ COUNTERSUNK HEAD SCREW M6X30		1		
076	265776-8	THUMB SCREW M6X26		1		
077	253111-2	FLAT WASHER 6		1		
078	319865-2	FRONT ANGULAR PLATE		1		
079	263041-9	SHOULDER PIN 3-5		1		
080	231234-6	COMPRESSION SPRING 3.5		1		
081	266559-9	H.S.BUTTON HEAD BOLT M6X4		1		
082	450704-8	DIAL 27		1		
083	251370-2	+ PAN HEAD SCREW M5		1		
084	251528-3	+ PAN HEAD SCREW M6		1		
085	257580-9	SLEEVE 8		1		
086	266229-0	H.S.SET SCREW(CUP POINT)M5X8		1		
087	911118-1	PAN HEAD SCREW M4X12		1		
088	419632-6	POSITION PLATE		1		
089	216008-6	STEEL BALL 4		1		
090	233314-4	COMPRESSION SPRING 4		1		
091	347574-3	DEPTH GUIDE		1		
092	140P89-3	FRAME COMPLETE		1		
C10	233025-1	COMPRESSION SPRING 2		2		
C20	259008-3	PUSH NUT 4		2		
C30	286041-2	CAP 14		2		
C40	345747-2	SPACER PLATE		2		
C50	347392-9	PLATE		2		
093	252014-7	HEX. LOCK NUT M6-10		1		
094	265A83-5	H.S.SET SCREW(FLAT POINT)M5X 20		1		
095	233025-1	COMPRESSION SPRING 2		1		
096	412210-1	SLIDER		1		
097	265A84-3	PAN HEAD SCREW M4X12 WITH WR		2		
098	266332-7	R.H SQUARE NECK BOLT M6X35		1		
099	319866-0	REAR ANGULAR PLATE		1		
100	253111-2	FLAT WASHER 6		1		
101	252270-9	THUMB NUT M6		1		
102	263041-9	SHOULDER PIN 3-5		1		
103	231234-6	COMPRESSION SPRING 3.5		1		
104	266559-9	H.S.BUTTON HEAD BOLT M6X4		1		
105	265701-9	THUMB SCREW M6X14		2		
106	233376-2	COMPRESSION SPRING 8		2		
107	265775-0	THUMB SCREW M4X3		2		
108	419627-9	HOLDER		2		
109	458092-7	SLIDE LEVER		2		
110	253932-2	WAVE WASHER 10		2		
111	345977-5	PLATE		2		
112	345748-0	LOCK WASHER		2		
113	912112-6	COUNTERSUNK HEAD SCREW M4 X10		2		
114	266225-8	H.S.SET SCREW(FLAT POINT)M6X 8		2		
115	319862-8	BASE		1		
116	265181-9	+TRUSS HEAD SCREW M5X20		4		

117	253811-4	FLAT WASHER 5		1		
118	620L68-8	CONTROLLER B	S	1		
119	652119-7	PAN HEAD SCREW M2X6	S	6		
A01	162687-7	SUB BASE		1		
A02	783204-6	HEX. WRENCH 6		1		
A03	E-01909	TCT BLADE 235X24T WOOD EFFI CUT		1		
F02	194367-7	GUIDE RAIL 3000 SET		1		
F03	194368-5	GUIDE RAIL 1400 SET		1		
F05	194416-0	SHEET 10000 SET		1		
F06	194417-8	RUBBER SHEET 10000 SET		1		
F07	194418-6	POSITION SHEET 1400 SET		1		
F09	194910-2	POSITION SHEET 1900 SET		1		
F11	194925-9	GUIDE RAIL 1900 SET		1		
F13	195546-0	FRONT CUFF 24 SET		1		
F14	196664-7	BEVEL GUIDE SET		1		
F16	198885-7	GUIDE RAIL CONNECTOR SET(EU)		1		
F17	199140-0	GUIDE RAIL 1000 SET		1		
F18	199141-8	GUIDE RAIL 1500 SET		1		
F28	1913K7-3	PARALLEL GUIDE SET(MM)		1		
A04	198900-7	WIRELESS UNIT SET		1	*	
A04-1	198900-7	WIRELESS UNIT SET	<	1	*	
A04-2	198900-7	WIRELESS UNIT SET	<	1		

Please state Parts No. when your order.

Print Date 24/10/2023