

# Model No.DSS610 CORDLESS CIRCULAR SAW 165MM

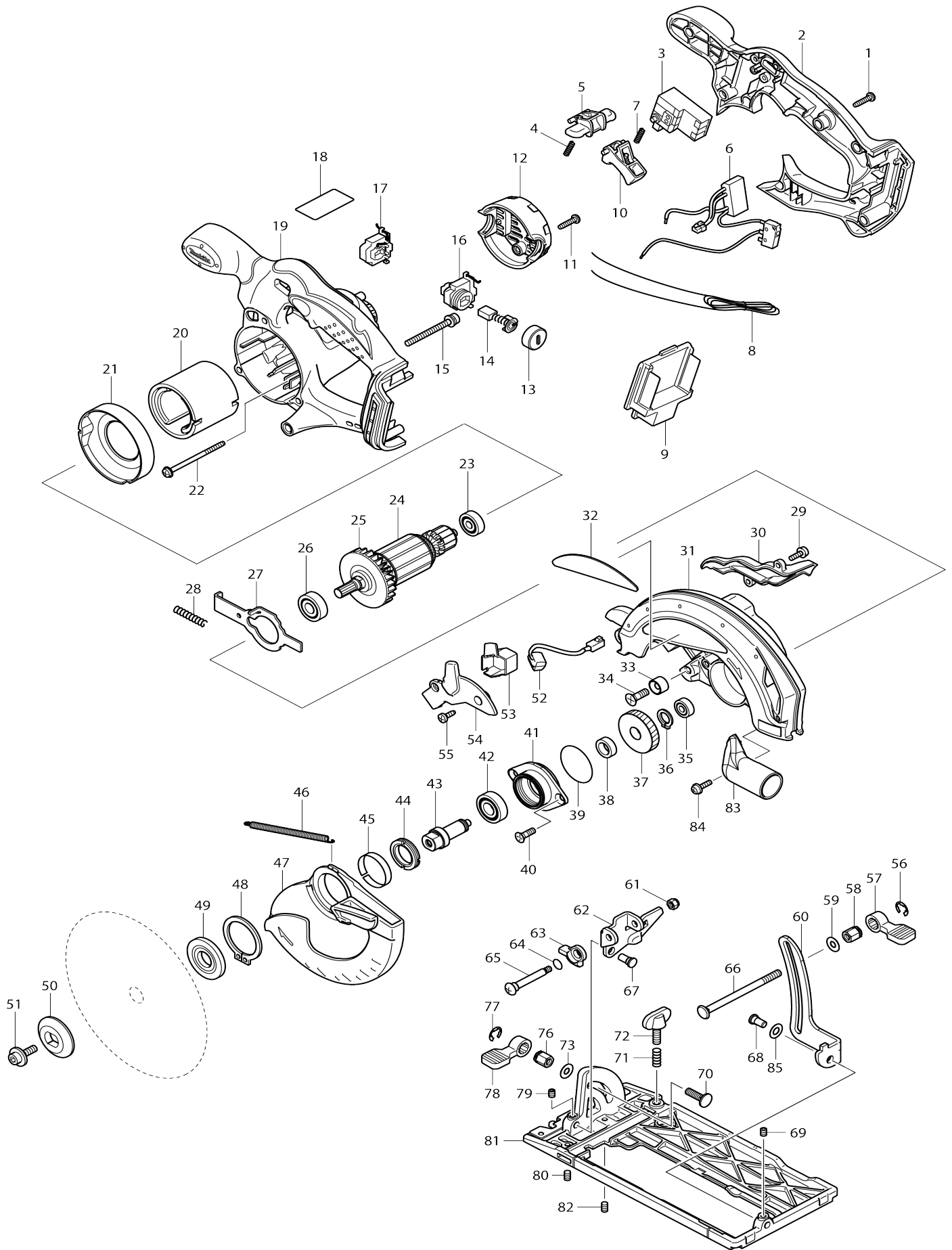

Model No.DSS610 CORDLESS CIRCULAR SAW 165MM

Item No.	Parts No.	Description	Interchangeability	Q'ty	New/Old	Note1	Note2
001	265995-6	TAPPING SCREW 4X18		6	*		
001-1	266326-2	TAPPING SCREW 4X18	O	6			
002	141470-5	HANDLE COVER COMPLETE		1			
003	650631-1	SWITCH		1			
004	231469-9	COMPRESSION SPRING 4		1			
005	419322-1	LOCK OFF LEVER		1			
006	620088-0	POWER SUPPLY CIRCUIT		1			
007	231469-9	COMPRESSION SPRING 4		1			
009	644808-8	TERMINAL		1			
010	419176-6	SWITCH LEVER		1			
011	265995-6	TAPPING SCREW 4X18		2	*		
011-1	266326-2	TAPPING SCREW 4X18	O	2			
012	419281-9	REAR COVER		1			
013	643941-3	BRUSH HOLDER CAP		2			
014	194435-6	CARBON BRUSH CB-441		1			
015	911263-2	PAN HEAD SCREW M5X40		3			
016	643882-3	BRUSH HOLDER		1			
017	643883-1	BRUSH HOLDER		1			
018	815E89-3	DSS610 NAME PLATE		1			
019	141471-3	MOTOR HOUSING COMPLETE		1			
020	638107-8	YOKE UNIT		1			
021	419285-1	BAFFLE PLATE		1			
022	266292-3	TAPPING SCREW 4X65		2			
023	210023-2	BALL BEARING 627DDW		1	*		
023-1	210193-7	BALL BEARING 627DDW	>	1			
024	519173-3	ARMATURE ASS'Y 18V		1	*		
D10		INC. 23,25,26					
024-1	510585-3	ARMATURE ASS'Y 18V	>	1			
D10		INC. 23,25,26					
025	241869-5	FAN 55		1			
026	211061-7	BALL BEARING 6000LLB		1	*		
026-1	210192-9	BALL BEARING 6000LLB	O	1			
027	346059-6	SHAFT LOCK		1			
028	233092-6	COMPRESSION SPRING 5		1			
029	911118-1	PAN HEAD SCREW M4X12		2			
030	419284-3	BLOWER NOZZLE		1			
031	188045-9	BLADE CASE SET		1			
C10	213434-0	O RING 26		1			
D10		INC. 32					
032	819217-2	MAKITA LOGO PLATE		1			
033	262049-0	RUBBER RING 6		1			
034	251368-9	+ COUNTERSUNK SCREW M6		1	*		
034-1	265694-0	+ COUNTERSUNK HEAD SCREW M6	O	1			
035	210028-2	BALL BEARING 606ZZ		1			
036	961052-5	RETAINING RING (EXT) S-12		1			
037	227156-6	SPUR GEAR 52		1			
038	257173-2	RING 12		1			

039	213512-6	O RING 39		1			
040	265034-2	+ COUNTERSUNK HEAD SCREW M5X16		2			
041	318009-1	BEARING BOX		1			
042	211131-2	BALL BEARING 6001DDW		1	*		
042-1	210216-1	BALL BEARING 6001DDW	>	1			
043	324626-7	SPINDLE		1	*		
043-1	327A37-1	SPINDLE	<	1			
044	285845-9	BEARING RETAINER 19-29		1			
045	345469-4	THICKNESS RING		1			
046	231821-1	TENSION SPRING 3		1			
047	419286-9	SAFETY COVER		1			
048	961152-1	RETAINING RING (EXT) S-34		1			
049	224397-5	INNER FLANGE 40		1			
050	224282-2	OUTER FLANGE 40		1			
051	266133-3	HEX. SOCKET HEAD BOLT M6X20		1			
052	631694-6	LED CIRCUIT		1			
053	419341-7	CONNECTOR BOX		1			
054	419282-7	LIGHT COVER		1			
055	266026-4	TAPPING SCREW BIND CT 4X12		2			
056	961014-3	STOP RING E-8		1			
057	272229-0	LEVER 40		1			
058	252158-3	HEX.NUT M6		1			
059	941151-9	FLAT WASHER 6		1			
060	345658-1	DEPTH GUIDE		1			
061	252103-8	HEX. LOCK NUT M5-8		1			
062	345657-3	ANGULAR GUIDE		1			
063	317986-4	STOPPER		1			
064	213062-1	O RING 9		1			
065	265084-7	+ TRUSS HEAD SCREW M5		1			
066	266194-3	FLAT HEAD SCREW M6X90		1			
067	256480-0	SHOULDER PIN 6-7		1			
068	256480-0	SHOULDER PIN 6-7		1			
069	266264-8	H.S.SET SCREW(FLAT POINT)M5X 6		1			
070	251919-8	CAP SQUARE NECK BOLT M6X20		1			
071	231007-7	COMPRESSION SPRING 6		1			
072	251896-4	SCREW M5X20		1			
073	941151-9	FLAT WASHER 6		1			
076	252133-9	HEX. NUT M6		1			
077	961014-3	STOP RING E-8		1			
078	272251-7	LEVER 30		1			
079	266264-8	H.S.SET SCREW(FLAT POINT)M5X 6		1			
080	266229-0	H.S.SET SCREW(CUP POINT)M5X8		1			
081	154832-8	BASE COMPLETE		1			
C10	816851-9	SCALE PLATE		1			
082	266229-0	H.S.SET SCREW(CUP POINT)M5X8		1			
083	419283-5	DUST NOZZLE		1			
084	911118-1	PAN HEAD SCREW M4X12		1			
085	253186-1	FLAT WASHER 7		1			
A01	164095-8	GUIDE RULE		1			

A02	783203-8	HEX. WRENCH 5		1		
A03	A-85101	T.C.T.SAW BLADE 165X24TX20		1		
A04	141353-9	PLASTIC CARRYING CASE COMPL ETE		1		
C10	163455-1	LATCH		2		
C20	419360-3	HANDLE		1		
A05	***DC18RC	DC18RC FAST CHARGER		1		
A06	194204-5	BATTERY BL1830 SET		1	*	
A06-1	194204-5	BATTERY BL1830 SET	O	1	*	
A06-2	197600-6	BATTERY BL1830B SET	<	1	*	
A06-3	197600-6	BATTERY BL1830B SET	O	1		
A07	802U19-9	DSS610RF PLASTIC CASE LABEL		1		
E01	620258-1	CONTROLLER		1	*	
E01-1	620G71-9	CONTROLLER	<	1		
E02	688163-8	LINE FILTER		1		
F08-3	197606-4	BATTERY BL1830B SET (2PIECES)	O	1		
F11-2	196235-0	BATTERY BL1815N SET	O	1		
F12-1	196449-1	BATTERY BL1815N SET	O	1		
F13-2	196449-1	BATTERY BL1815N SET	O	1		
A07	802U23-8	DSS610RFE PLASTIC CASE LABEL		1	*	
A08	450128-8	BATTERY COVER		1		
A04	821551-8	CONNECTOR PLASTIC CASE (TYP E3)		1		
C10	453974-8	LATCH		4		
A07	837642-5	INNER TRAY		1		
A09	802U09-2	DSS610RFJ INDICATION LABEL		1		
A10	802U22-0	DSS610RFJ PLASTIC CASE LABEL		2		
A05	837642-5	INNER TRAY		1		
A06	802U10-7	DSS610ZJ INDICATION LABEL		1		
A07	802U17-3	DSS610ZJ PLASTIC CASE LABEL		2		
A06	196399-0	BATTERY BL1840 SET		2	*	
A06-1	196399-0	BATTERY BL1840 SET	O	2	*	
A06-2	197265-4	BATTERY BL1840B SET	<	2	*	
A06-3	197265-4	BATTERY BL1840B SET	O	2		
A09	803S46-7	DSS610RMJ INDICATION LABEL		1		
A10	803S45-9	DSS610RMJ PLASTIC CASE LABEL		2		
A06-2	197280-8	BATTERY BL1850B SET		2	*	
A06-3	197280-8	BATTERY BL1850B SET	O	2		
A09	808Y64-6	DSS610RTJ INDICATION LABEL		1		
A10	810E02-6	DSS610RTJ PLASTIC CASE LABEL		2		

Please state Parts No. when your order.

Print Date 12/09/2023