

Model No.DTR181 CORDLESS REBAR TYING TOOL

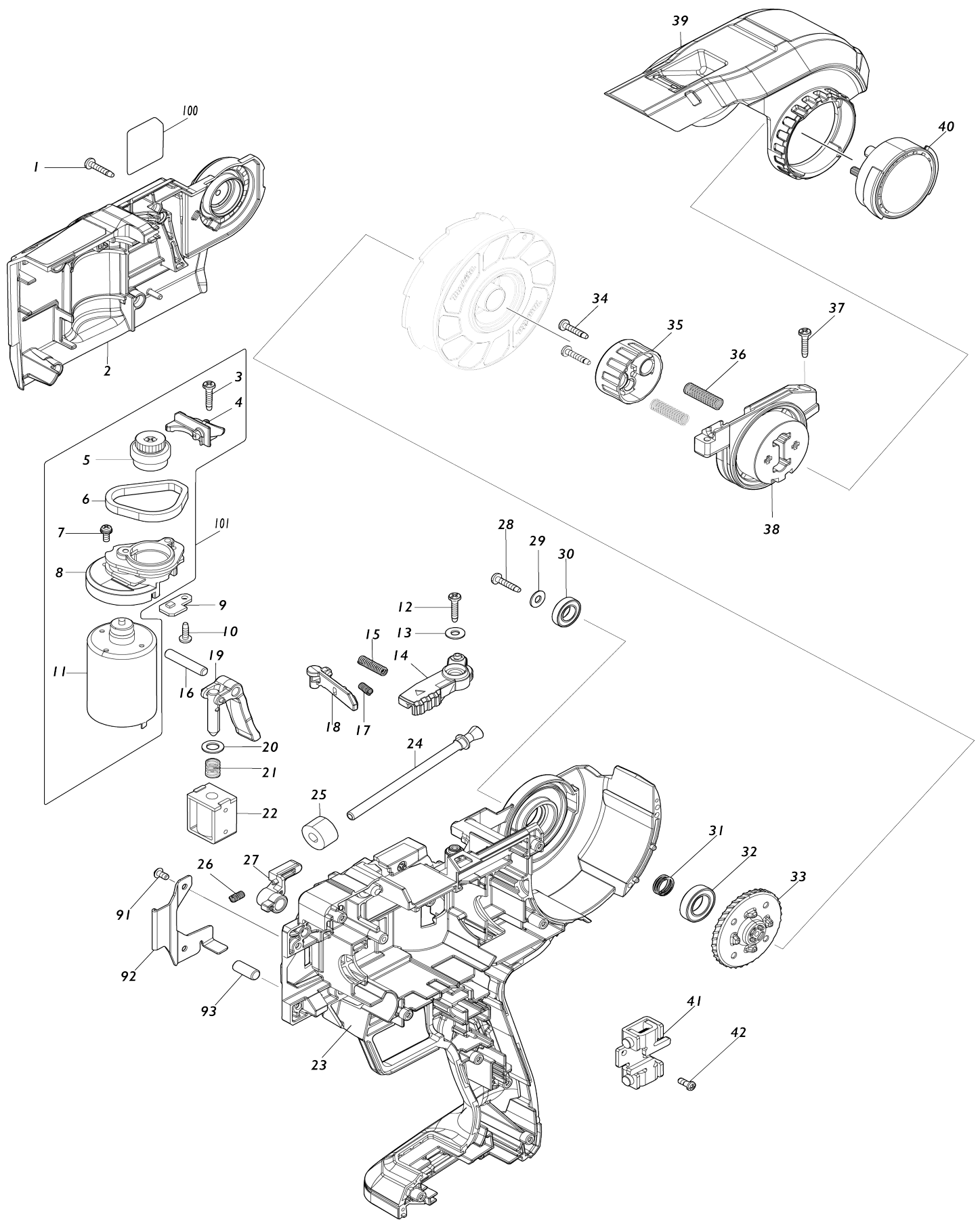

Model No.DTR181 CORDLESS REBAR TYING TOOL

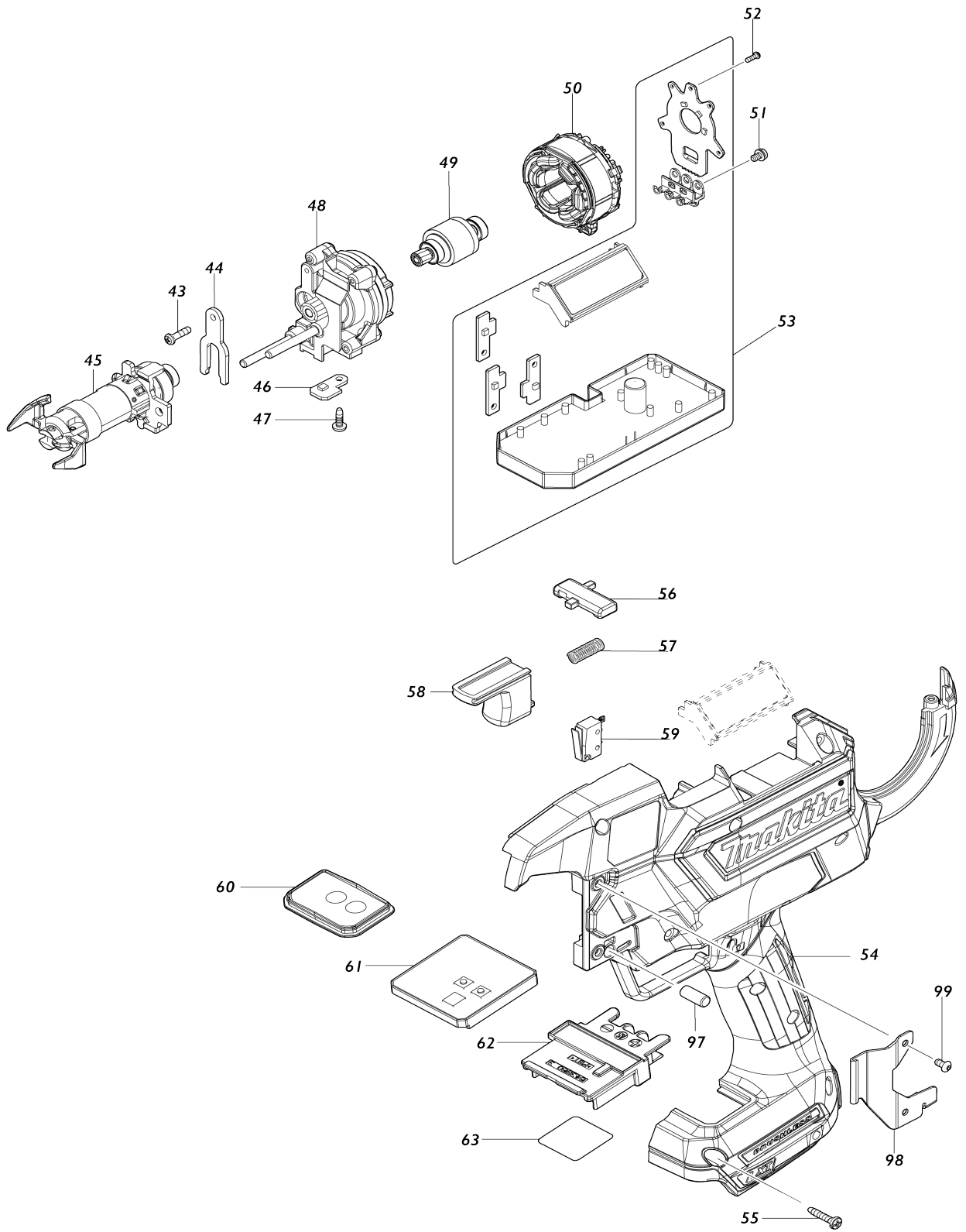

Model No.DTR181 CORDLESS REBAR TYING TOOL

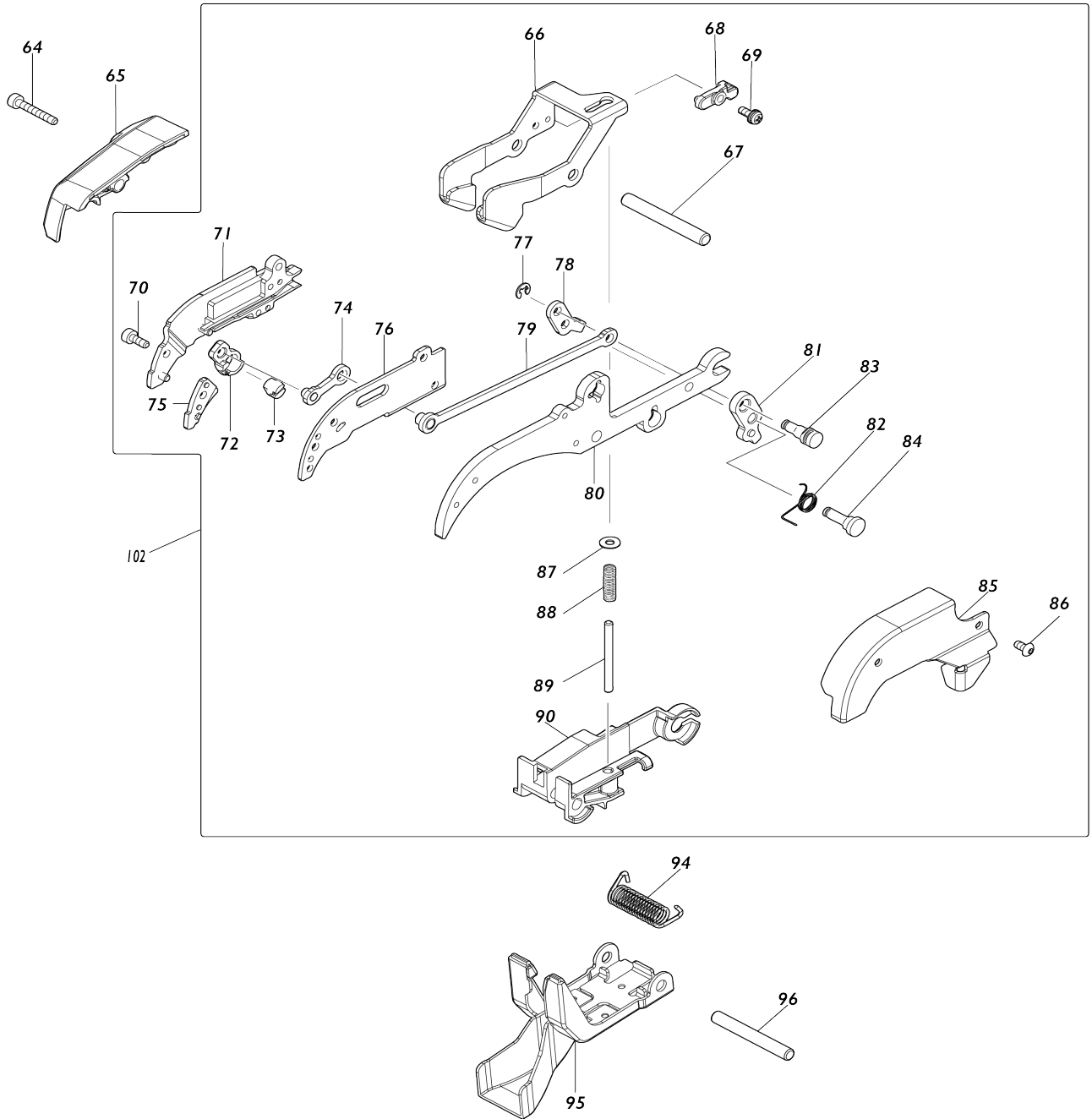

Model No.DTR181 CORDLESS REBAR TYING TOOL

Item No.	Parts No.	Description	Interchangability	Q'ty	New/Old	Note1	Note2
001	266130-9	TAPPING SCREW BIND PT 3X16		4			
002	140V64-5	HOUSING COVER COMPLETE		1			
C10	817A35-8	INDICATION LABEL A		1			
C20	817A42-1	CAUTION LABEL A		1			
C30	817A44-7	CAUTION LABEL B		1			
003	266130-9	TAPPING SCREW BIND PT 3X16		1			
004	310864-7	WIRE GUIDE A		1			
005	135968-2	SPUR GEAR 30A ASSEMBLY		1			
006	422247-0	SPONGE SHEET A		1			
007	911008-8	PAN HEAD SCREW M3X8		2			
008	458222-0	MOTOR BASE		1			
009	620913-5	SENSOR CIRCUIT		1			
010	266007-8	TAPPING SCREW BIND PT 3X10		1			
011	629346-1	DC MOTOR		1			
012	266130-9	TAPPING SCREW BIND PT 3X16		1			
013	941051-3	FLAT WASHER 4		1			
014	136675-0	RELEASE LEVER ASS'Y		1			
015	232443-0	COMPRESSION SPRING 3		1			
016	256098-7	PIN 5		1			
017	232442-2	COMPRESSION SPRING 3		1			
018	458223-8	LOCK LEVER		1			
019	140A85-1	BRAKE ARM COMPLETE		1			
020	941152-7	FLAT WASHER 6		1			
021	232446-4	COMPRESSION SPRING 7		1			
022	679032-4	SOLENOID		1			
023	183W01-2	HOUSING SET		1			
C10	263005-3	RUBBER PIN 6		2			
C20	252126-6	HEX. LOCK NUT M4-7		2			
C30	931002-4	HEX. NUT M3		6			
C40	817A46-3	CAUTION LABEL C		1			
D10		INC. 54					
024	140L14-0	WIRE GUIDE PIPE COMPLETE		1			
025	422249-6	SPONGE SHEET B		1			
026	232442-2	COMPRESSION SPRING 3		1			
027	144901-3	MAGNET ARM CCOMPLETE		1			
028	266130-9	TAPPING SCREW BIND PT 3X16		1			
029	941051-3	FLAT WASHER 4		1			
030	211478-4	BALL BEARING 689		1			
031	232508-8	COMPRESSION SPRING 10		1			
032	211136-2	BALL BEARING 6801LLB		1			
033	140H97-6	MAGNET WHEEL COMPLETE		1			
034	266130-9	TAPPING SCREW BIND PT 3X16		2			
035	319822-0	REEL BEARING		1			
036	231294-8	COMPRESSION SPRING 6		2			
037	266130-9	TAPPING SCREW BIND PT 3X16		2			
038	458225-4	REEL BASE		1			
039	458216-5	REEL COVER		1			

040	458221-2	REEL BEARING CAM		1		
041	126743-7	STOPPER ASSEMBLY		1		
042	265199-0	+ PAN HEAD SCREW M3X8		2		
043	911017-7	PAN HEAD SCREW M3X12		1		
044	310866-3	BEARING RTAINER		1		
045	141D23-4	MAIN SLEEVE COMPLETE		1		
046	620913-5	SENSOR CIRCUIT		1		
047	266007-8	TAPPING SCREW BIND PT 3X10		1		
048	126838-6	GEAR ASSEMBLY		1		
049	619520-9	ROTOR		1		
050	629343-7	STATOR		1		
051	652069-6	FLAT HEAD SCREW M3X6		3		
052	266490-9	TAPPING SCREW PT 2X6		3		
053	140X54-0	MAIN CONTROLLER COMPLETE		1		
C10	817A37-4	INDICATION LABEL B		1		
054	183W01-2	HOUSING SET		1		
C10	263005-3	RUBBER PIN 6		2		
C20	252126-6	HEX. LOCK NUT M4-7		2		
C30	931002-4	HEX. NUT M3		6		
C40	817A46-3	CAUTION LABEL C		1		
D10		INC. 23				
055	266130-9	TAPPING SCREW BIND PT 3X16		11		
056	458219-9	TRIGGER LOCK		1		
057	234037-7	COMPRESSION SPRING 5		1		
058	458220-4	TRIGGER		1		
059	632L94-5	SWITCH UNIT		1		
060	140B67-9	SWITCH PLATE COMPLETE		1		
C10	817A39-0	INDICATION LABEL C		1		
061	620924-0	SWITCH CIRCUIT		1		
062	643860-3	TERMINAL		1		
063	811K07-5	DTR181 SERIAL NO. LABEL		1		
064	265633-0	HEX SOCKET HEAD BOLT M3X20		1		
065	458217-3	CONTACT PLATE COVER		1		
066	347831-9	CONTACT PLATE		1		
067	256573-3	PIN 5		1		
068	144903-9	MAGNET BASE B COMPLETE		1		
069	911008-8	PAN HEAD SCREW M3X8		1		
070	265634-8	HEX SOCKET HEAD BOLT M3X8		1		
071	162945-1	WIRE GUIDE B COMPLETE		1	*	
071-1	141S52-7	WIRE GUIDE B COMPLETE	<	1		
072	310815-0	CUTTER B		1		
073	310814-2	CUTTER A		1		
074	161872-9	LINK ARM A COMPLETE		1		
075	347773-7	TOP PLATE		1		
076	347772-9	GUIDE PLATE A		1		
077	961017-7	STOP RING E-3		2		
078	347720-8	PULL PLATE		1		
079	162943-5	LINK ARM B COMPLETE		1		
080	347770-3	GUIDE ARM A		1		
081	347329-6	PUSH PLATE		1		
082	232445-6	TORSION SPRING 7		1		
083	256400-4	SHOULDER PIN 4		1		

084	256399-3	SHOULDER PIN 4		1		
085	347771-1	GUIDE PLATE B		1		
086	265635-6	H.S.BUTTON HEAD SCREW M3X6		2		
087	941001-8	FLAT WASHER 3		1		
088	232444-8	COMPRESSION SPRING 4		1		
089	256390-1	PIN 3		1		
090	458226-2	LEAD HOLDER		1		
091	265635-6	H.S.BUTTON HEAD SCREW M3X6		2		
092	347813-1	SIDE PLATE R		1		
093	263040-1	RUBBER PIN 6		1		
094	232448-0	TORSION SPRING 6		1		
095	162946-9	CURL GUIDE COMPLETE		1		
096	256573-3	PIN 5		1		
097	263040-1	RUBBER PIN 6		1		
098	347812-3	SIDE PLATE L		1		
099	265635-6	H.S.BUTTON HEAD SCREW M3X6		2		
100	811K01-7	DTR181 NAME PLATE		1		
101	135999-1	DC MOTOR ASSY		1		
D10		INC. 3-8,11				
102	136447-3	GUIDE ARM ASSY		1	*	
D10		INC. 66-90				
102-1	136948-1	GUIDE ARM ASSY	<	1		
D10		INC. 66-90				
A01	251314-2	+ SCREW M4X12		1		
A02	346449-3	HOOK		1		
A03	783208-8	HEX. WRENCH 2.5		1		
A04	162755-6	NYLON BRUSH		1		
A05	140563-9	CONNECTOR P.CASE (TYPE4) CO MP.		1		
C10	453974-8	LATCH		4		
C20	8008X6-2	CAUTION LABEL		1		
A06	8035D2-1	DTR181ZJ INDICATION LABEL		1		
A07	8035D3-9	DTR181ZJ PLASTIC CASE LABEL		2		
A08	835W33-2	INNER TRAY		1	*	
A08-1	8351L5-9	INNER TRAY	<	1		
F02	191J59-9	POLY COATED TIE WIRE SET		1		
F03	191M27-0	EXTENSION HANDLE SET		1		
F06	1911H9-6	WIRE GUIDE B COMPLETE(EG) SET		1	*	
F06-1	1913F2-8	WIRE GUIDE B COMPLETE(EG) SET	<	1		

Please state Parts No. when your order.

Print Date 25/10/2023