

# Model No.DTW251 CORDLESS IMPACT WRENCH

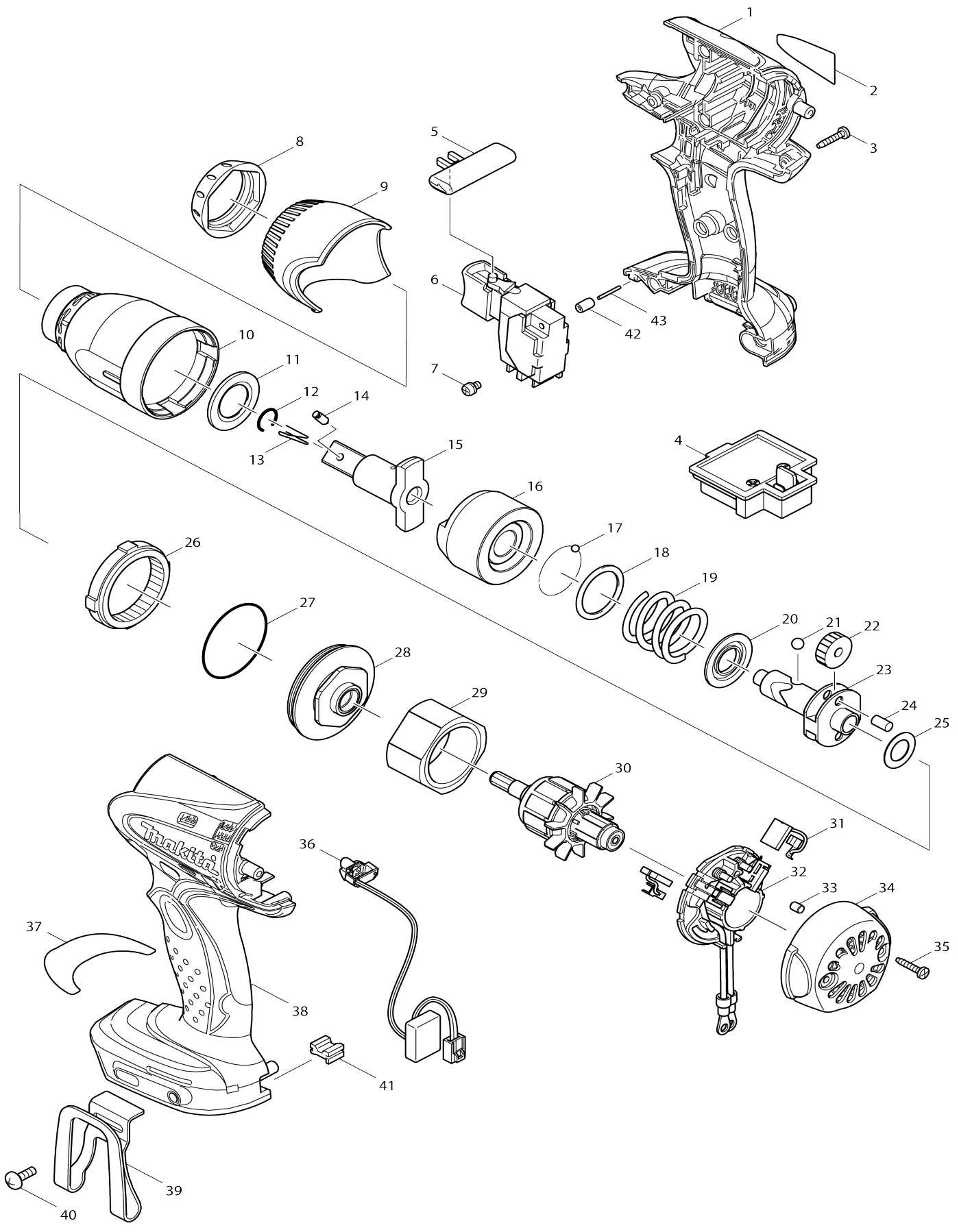

Model No.DTW251 CORDLESS IMPACT WRENCH

Item No.	Parts No.	Description	Interc hang eabilit y	Q'ty	New/ Old	Note1	Note2
001	188243-5	HOUSING SET		1			
C10	263005-3	RUBBER PIN 6		2			
D10		INC. 38					
002	815E48-7	DTW251 NAME PLATE		1	*		
002-1	857J88-9	DTW251 NAME PLATA	S	1			
003	266130-9	TAPPING SCREW BIND PT 3X16		8			
A02	194204-5	BATTERY BL1830 SET		2	*		
004	643852-2	TERMINAL		1			
005	419041-9	F/R CHANGE LEVER		1			
006	650652-3	SWITCH TG553FSB-1B		1			
007	652045-0	+PAN HEAD SCREW M3.5X5		2			
008	424375-7	BUMPER		1			
009	452439-7	HAMMER CASE COVER		1			
010	140171-2	HAMMER CASE COMPLETE		1			
011	261116-8	NYLON WASHER 18		1			
012	231907-1	RING SPRING 10		1			
015	324706-9	ANVIL		1			
016	324703-5	HAMMER		1			
017	216001-0	STEEL BALL 3.5		24	*		
017-1	216040-0	STEEL BALL 3.5	O	24			
018	267175-0	FLAT WASHER 24		1			
019	234337-5	COMPRESSION SPRING 25		1			
020	267766-7	CUP WASHER 14		1			
021	216011-7	STEEL BALL 5.6		2			
022	227233-4	SPUR GEAR 22		2			
023	324220-5	SPINDLE		1			
024	256253-1	PIN 5		2			
025	267212-0	FLAT WASHER 12		1			
026	227150-8	INTERNAL GEAR 51		1			
027	213507-9	O RING 40		1			
028	158145-9	BEARING BOX COMPLETE		1	*		
028-1	143035-9	BEARING BOX COMPLETE	O	1			
029	638495-3	YORK UNIT		1			
030	619253-6	ARMATURE		1	*		
030-1	619375-2	ARMATURE	<	1			
031	196854-2	CARBON BRUSH CB-448		1	*		
031-1	196854-2	CARBON BRUSH CB-448	S	1	*		
031-2	198887-3	CARBON BRUSH CB-5	S	1			
032	638853-3	BRUSH HOLDER COMPLETE		1	*		
032-1	632G50-5	BRUSH HOLDER COMPLETE	S	1	*		
C10	689181-9	SPACER		2	*		
D10		INC. 31					
032-2	632L19-9	BRUSH HOLDER COMPLETE	<	1			
D10		INC. 31					
033	263032-0	RUBBER PIN 4		2			
034	418981-8	REAR COVER		1			
035	266130-9	TAPPING SCREW BIND PT 3X16		2			

036	631693-8	LIGHT CIRCUIT		1		
038	188243-5	HOUSING SET		1		
C10	263005-3	RUBBER PIN 6		2		
D10		INC. 1				
039	346317-0	HOOK		1		
040	251314-2	+ SCREW M4X12		1		
041	424026-2	CUSHION		1	*	
041-1	424476-1	CUSHION	O	1		
042	263036-2	RUBBER PIN 5		1		
043	268184-2	PIN 1.5		1		
044	857J89-7	DTW251 SERIAL NO. LABEL	S	1		
F35	194654-4	HOOK SET		1		
C10	251314-2	+ SCREW M4X12		1		
C20	324705-1	HOOK		1		
F36	194649-7	BATTERY PROTECTOR		1		
C10	251314-2	+ SCREW M4X12		2		
F37-3	197606-4	BATTERY BL1830B SET (2PIECES)	O	1	*	
F42-2	196235-0	BATTERY BL1815N SET	O	1		
F43-1	196449-1	BATTERY BL1815N SET	O	1		
F44-2	196449-1	BATTERY BL1815N SET	O	1		
F53	191B20-8	BIT ADAPTER SET		1		
A01	***DC18RC	DC18RC FAST CHARGER		1		
A02	194204-5	BATTERY BL1830 SET		2	*	
A02-1	194204-5	BATTERY BL1830 SET	O	2	*	
A02-2	197600-6	BATTERY BL1830B SET	<	2	*	
A02-3	197600-6	BATTERY BL1830B SET	O	2		
A03	141205-4	PLASTIC CARRYING CASE		1		
C10	324207-7	SHAFT		1		
C20	413098-2	PLATE		4		
C30	417724-5	LATCH		2		
C40	419215-2	PLASTIC CASE LID		1		
C50	419216-0	HANDLE		1		
A04	802V76-3	DTW251RFE PLASTIC CASE LABEL		1	*	
A04-1	804M50-3	DTW251RFE MODEL NO. LABEL	<	1		
A05	450128-8	BATTERY COVER		1		
A03	821550-0	CONNECTOR PLASTIC CASE (TYP E2)		1		
C10	453974-8	LATCH		4		
A04	837670-0	INNER TRAY		1		
A06	802V72-1	DTW251RFJ INDICATION LABEL		1		
A07	802V73-9	DTW251RFJ PLASTIC CASE LABEL		2	*	
A07-1	805V38-0	DTW251RFJ PLASTIC CASE LABEL	<	2		
A06	802V74-7	DTW251ZJ INDICATION LABEL		1		
A07	802V75-5	DTW251ZJ PLASTIC CASE LABEL		2	*	
A07-1	805V39-8	DTW251ZJ PLASTIC CASE LABEL	<	2		
A02	196399-0	BATTERY BL1840 SET		2	*	
A02-1	196399-0	BATTERY BL1840 SET	O	2	*	
A02-2	197265-4	BATTERY BL1840B SET	<	2	*	
A02-3	197265-4	BATTERY BL1840B SET	O	2		
A06	802V85-2	DTW251RMJ INDICATION LABEL		1		
A07	802V86-0	DTW251RMJ PLASTIC CASE LABEL		2	*	

A07-1	805V40-3	DTW251RMJ PLASTIC CASE LABEL	<	2	*		
A07-2	807W57-8	DTW251RMJ PLASTIC CASE LABEL	<	2			
A02	197280-8	BATTERY BL1850B SET		2	*		
A02-1	197280-8	BATTERY BL1850B SET	O	2			
A06	809B55-2	DTW251RTJ INDICATION LABEL		1			
A07	809B56-0	DTW251RTJ PLASTIC CASE LABEL		2			

Please state Parts No. when your order.

Print Date 27/12/2023