

Model No.EA3600F PETROL CHAIN SAW

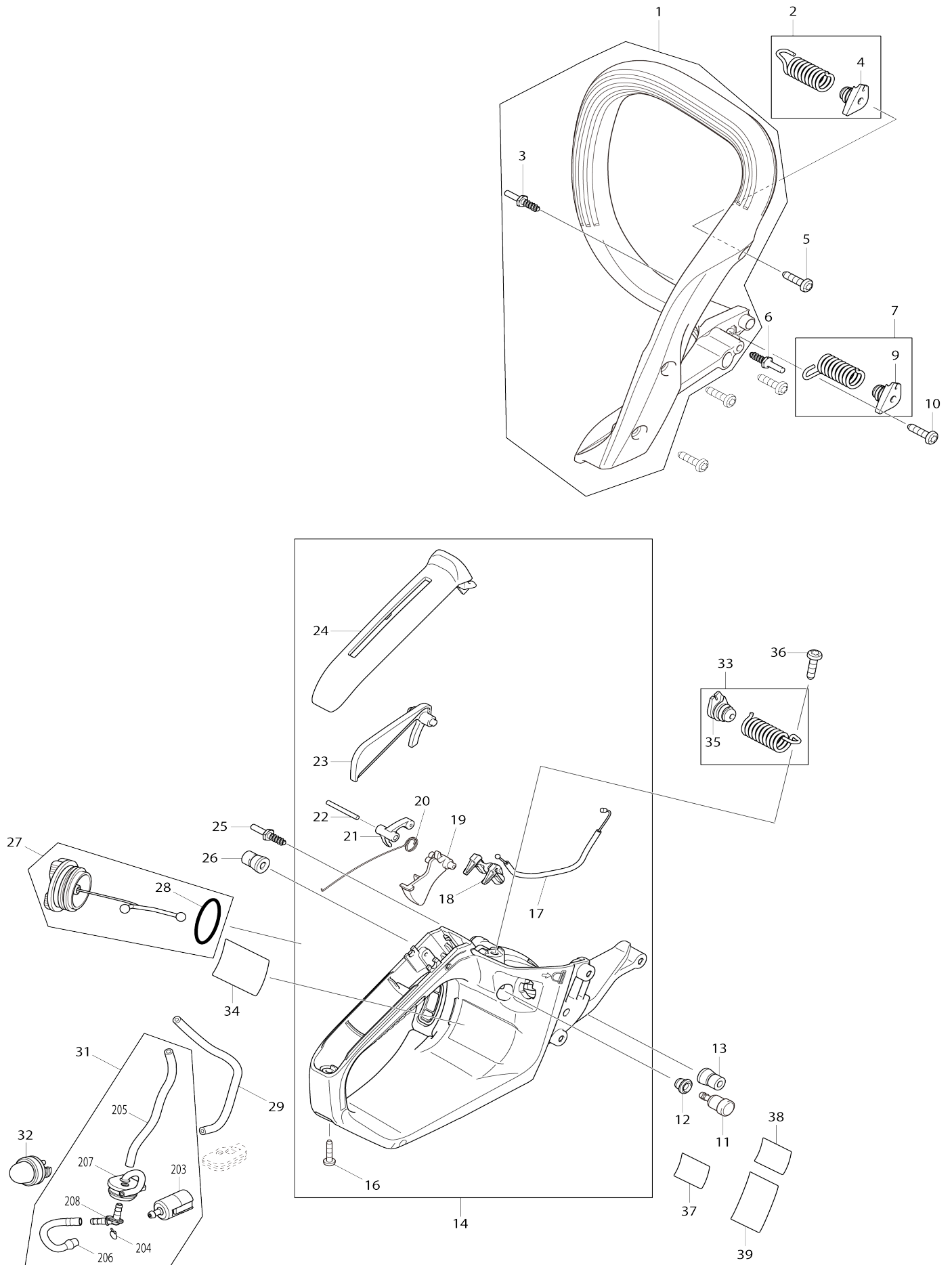

Model No.EA3600F PETROL CHAIN SAW

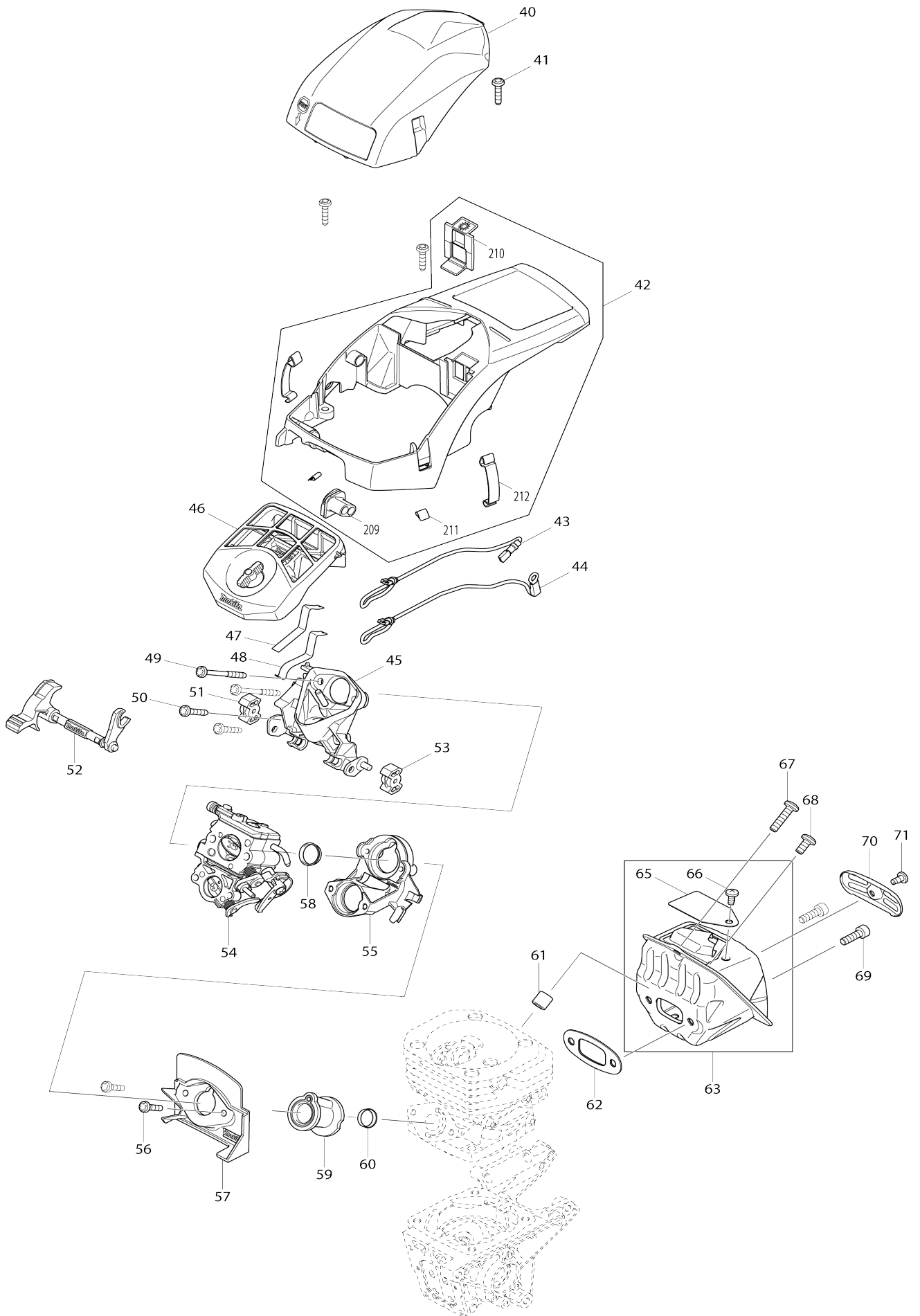

Model No.EA3600F PETROL CHAIN SAW

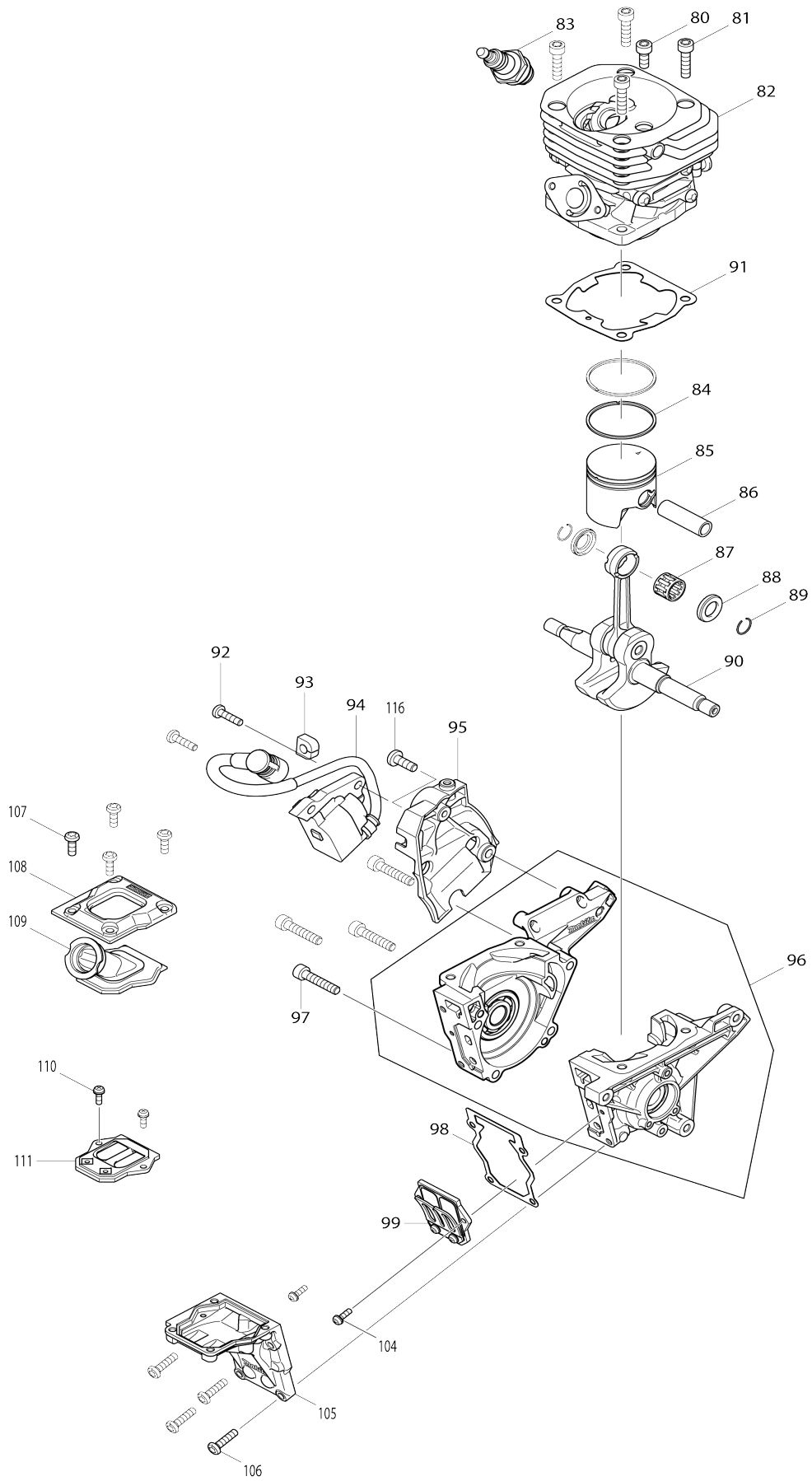

Model No.EA3600F PETROL CHAIN SAW

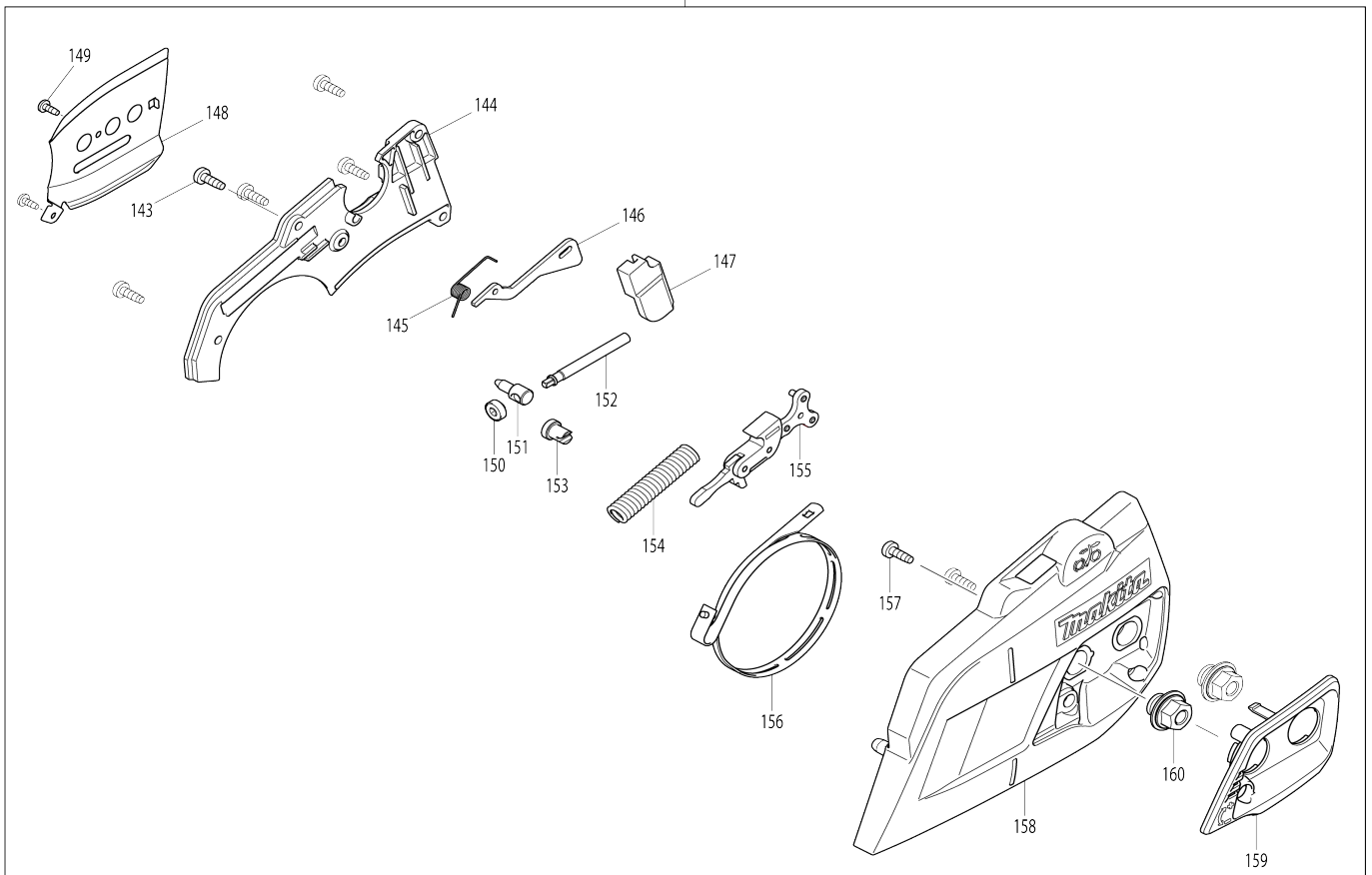
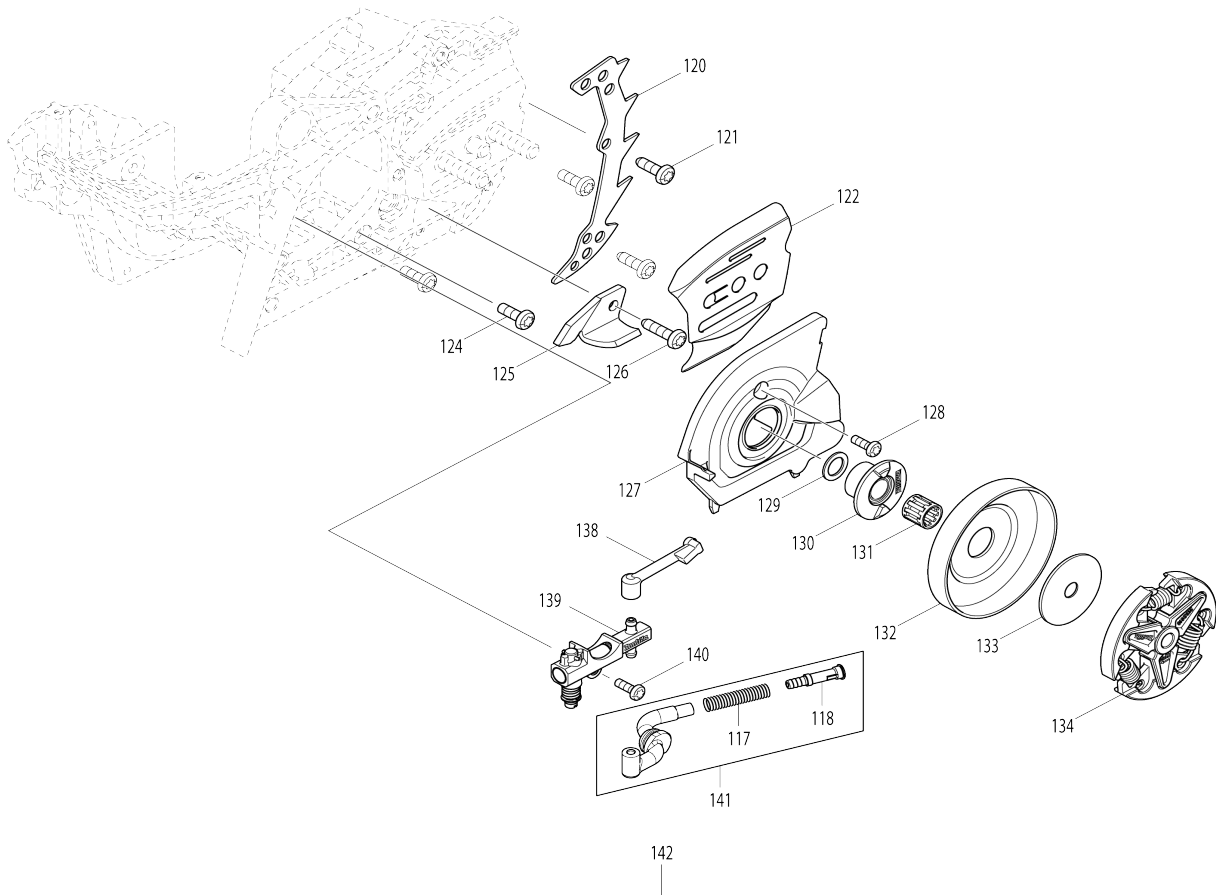

Model No.EA3600F PETROL CHAIN SAW

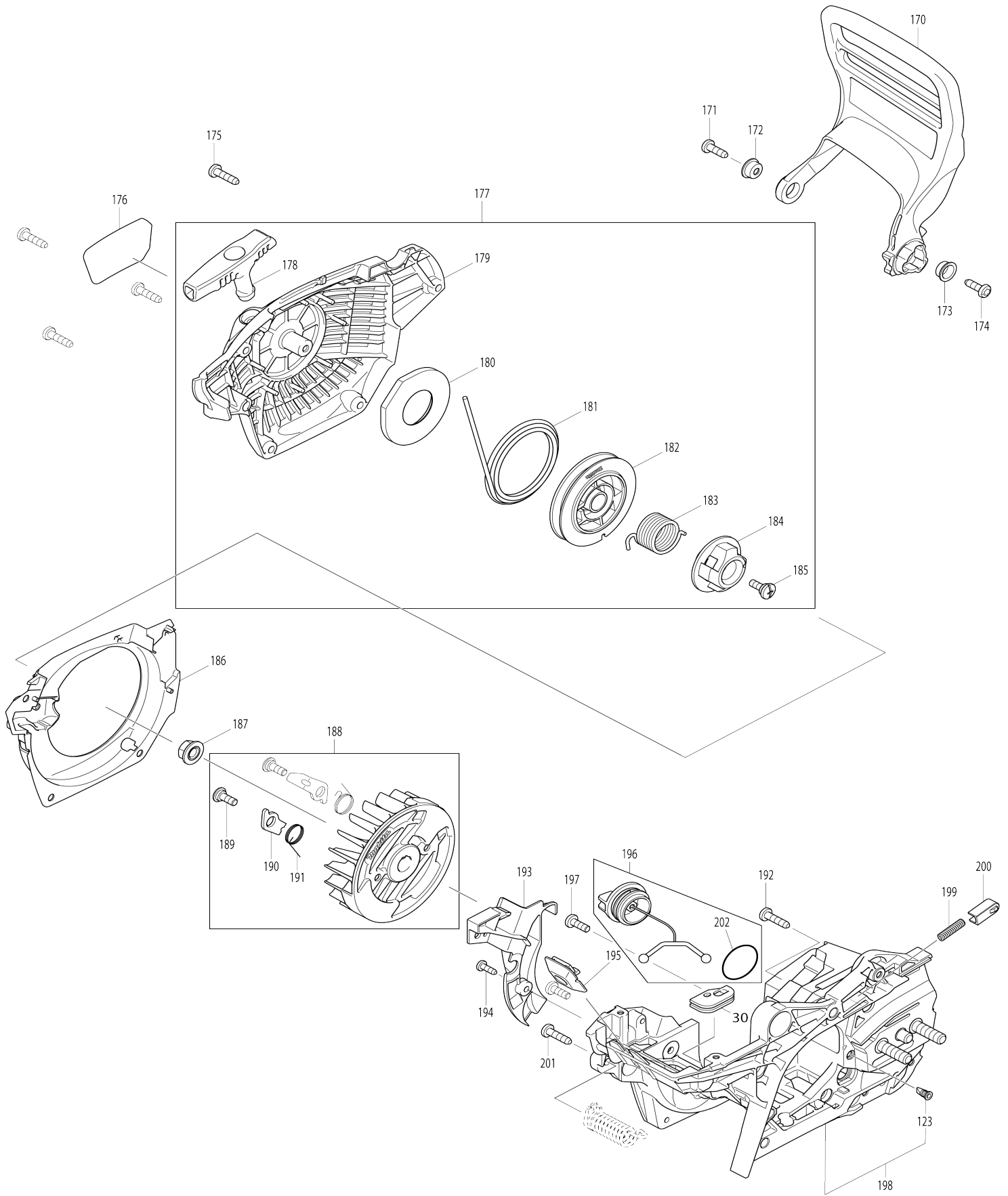

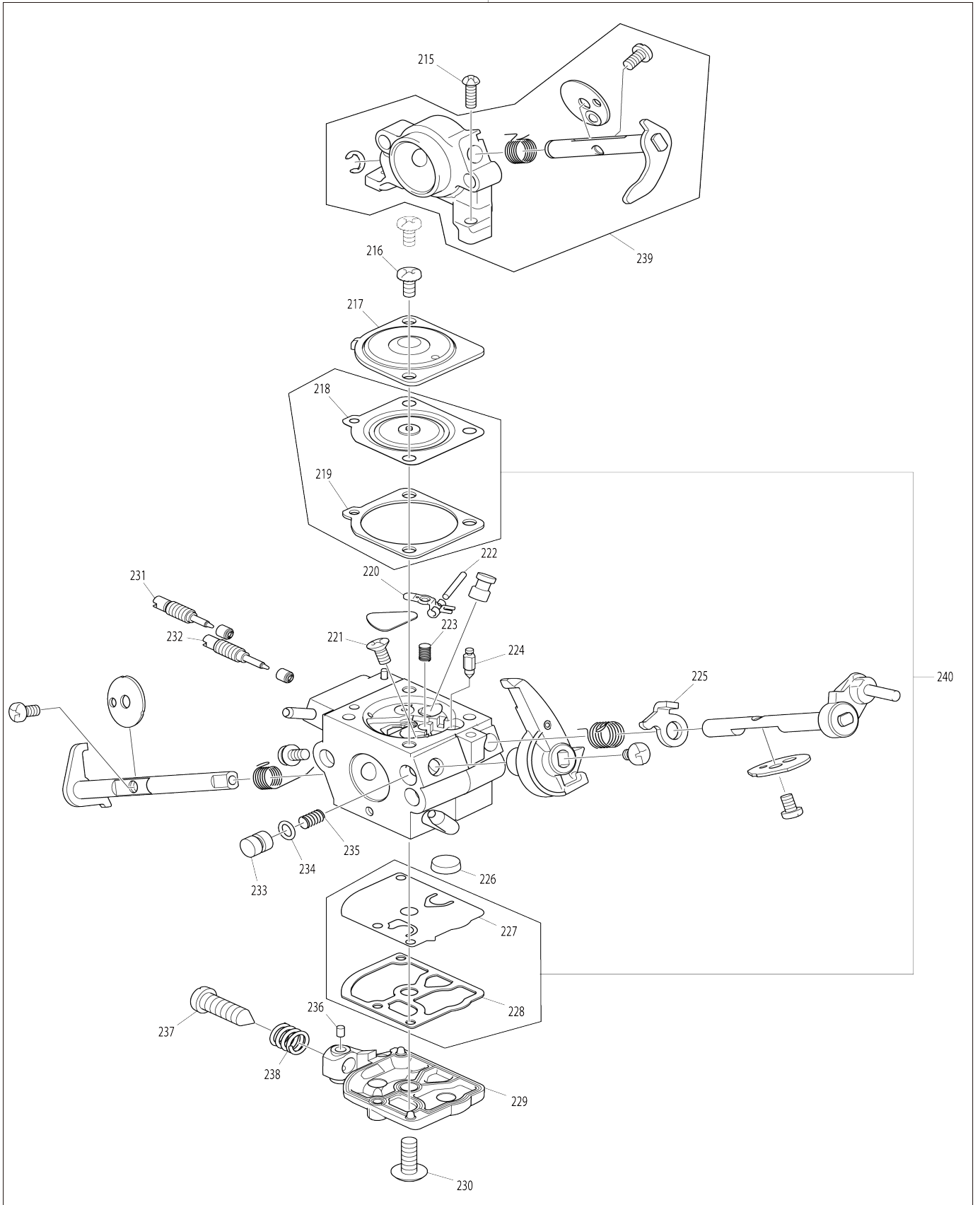

Model No.EA3600F PETROL CHAIN SAW

Item No.	Parts No.	Description	Interchangability	Q'ty	New/Old	Note1	Note2
001	142225-1	FRONT HANDLE COMPLETE		1			
D10		INC. 3					
002	142226-9	DAMPER SPRING R COMPLETE		1			
D10		INC. 4					
003	326339-6	STOPPER PIN		1			
004	454506-4	SPRING HOLDER		1			
005	266856-3	H.L. TAPPING SCREW 5X20		4			
006	326339-6	STOPPER PIN		1			
007	142227-7	DAMPER SPRING F COMPLETE		1			
D10		INC. 9					
009	454506-4	SPRING HOLDER		1			
010	266856-3	H.L. TAPPING SCREW 5X20		1			
011	168396-6	BREATHER		1			
012	424576-7	GROMMET		1			
013	424577-5	SIDE STOPPER		1			
014	126345-9	RIGHT HANDLE ASSEMBLY		1			
D10		INC. 16-24					
016	266858-9	H.L. TAPPING SCREW 4X18		1			
017	168812-8	THROTTLE CABLE		1			
018	454501-4	CABLE BRACKET		1			
019	454499-5	THROTTLE LEVER		1			
020	233606-1	RETURN SPRING		1			
021	454500-6	CABLE PULL LEVER		1			
022	268187-6	PIN 3		1			
023	454502-2	LOCKOUT LEVER		1			
024	454503-0	GRIP COVER		1			
025	326339-6	STOPPER PIN		1			
026	424577-5	SIDE STOPPER		1			
027-1	168823-3	TANK CAP COMPLETE		1			
D10		INC. 28					
028	213080-9	O RING 29.5		1			
029	422116-5	JOINT PIPE		1			
030	424573-3	DUST GROMMET		1			
031	126347-5	FUEL PIPE ASSEMBLY		1			
D10		INC. 203-208					
032	168398-2	PRIMER PUMP		1			
033	142226-9	DAMPER SPRING R COMPLETE		1			
D10		INC. 35					
034	814587-8	EA3600F NAME PLATE		1			
035	454506-4	SPRING HOLDER		1			
036	266856-3	H.L. TAPPING SCREW 5X20		1			
038	805U48-1	SOUND 111DB LABEL		1			
040	142239-0	CLEANER COVER COMPLETE		1			
C10	263002-9	RUBBER PIN 4		1			
041	266858-9	H.L. TAPPING SCREW 4X18		3			
042	126344-1	CYLINDER COVER ASSEMBLY		1			
D10		INC. 209-212					

043	632A97-3	SWITCH CORD		1		
044	632A98-1	EARTH CORD		1		
045-1	457411-4	MANOFOLD		1		
046	126370-0	CLEANER ASSEMBLY		1		
C10	454537-3	KNOB		1		
047	346704-3	EARTH PLATE		1		
048	346705-1	SWITCH SPRING		1		
049	266860-2	H.L. TAPPING SCREW 4X45		2		
050	266861-0	H.L. TAPPING SCREW 4X22		2		
051	424582-2	DAMPER		1		
052	454533-1	SWITCH LEVER		1		
053	424582-2	DAMPER		1		
054-1	161633-7	CARBURETOR ASSEMBLY		1	*	
D10		INC. 215-239				
054-2	161914-9	CARBURETOR ASSEMBLY	S	1		
D10		INC. 215-239				
055	454531-5	BRACKET		1		
056	266848-2	H.L.HEAD BIND BOLT M4X16		2		
057	454488-0	BUFFLE PLATE		1		
058	332074-6	INNER RING		1		
059	424571-7	INLET PIPE		1		
060	332075-4	INNER RING		1		
061	326304-5	SPACER		1		
062	413164-5	MUFFLER GASKET		1		
063	126342-5	MUFFLER ASSEMBLY		1	*	
D10		INC. 65,66				
063-1	126936-6	MUFFLER ASSEMBLY	S	1		
D10		INC. 65,66				
065	352023-7	SCREEN		1		
066	266796-5	TAPPING SCREW 4X8		1		
067	266851-3	H.L.BIND BOLT M5X20		1		
068	266850-5	H.L.BIND BOLT M5X10		1		
069	266849-0	H.L.SOCKET HEAD BOLT M5X16		2		
070	346691-6	DUST COVER		1		
071	266936-5	H.L.BIND BOLT M4X8		1		
080	266859-7	H.L.SOCKET HEAD BOLT M5X12		1		
081	266847-4	H.L.SOCKET HEAD BOLT M5X20		4		
082	142223-5	CYLINDER COMPLETE		1		
083	649500-1	SPARK PLUG (BPMR8Y)		1		
084	257365-3	PISTON RING		2		
085-1	319711-9	PISTON		1		
086	268331-5	PISTON PIN		1		
087	212127-6	NEEDLE CAGE 1011		1		
088	346698-2	THRUST WASHER		2		
089	234307-4	RETAINING RING		2		
090-1	140B29-7	CRANK SHAFT COMPLETE		1		
091	413163-7	BASE GASKET		1		
092	266848-2	H.L.HEAD BIND BOLT M4X16		2		
093	424581-4	GROMMET		1		
094	126350-6	IGNITION COIL ASSEMBLY		1		
C10	424580-6	PLUG CAP		1		
095	454520-0	PLATE		1		

096	142224-3	CRANK CASE COMPLETE		1		
C10	213697-8	OIL SEAL		2		
097	266852-1	H.L.SOCKET HEAD BOLT M5X25		4		
098	413165-3	GASKET		1		
099-1	123924-4	REED VALVE		1		
104	911013-5	PAN HEAD SCREW M3X10		2		
105	319022-2	REED VALVE COVER		1		
106	266848-2	H.L.HEAD BIND BOLT M4X16		4		
107	266846-6	H.L.BIND BOLT M4X12		4		
108	454489-8	BRACKET		1		
109	424572-5	AIR BOOT		1		
110	911013-5	PAN HEAD SCREW M3X10		2		
111-1	123923-6	REED VALVE		1		
116-1	251500-5	H.L. BIND BOLT M5X14		1		
117	234207-8	COMPRESSION SPRING 6		1		
118	452666-6	NIPPLE		1	*	
118-1	452666-6	NIPPLE	O	1		
120	346695-8	SPIKE BUMPER		1		
121	266857-1	H.L. TAPPING SCREW 5X16		2		
122	346694-0	GUIDE PLATE ES		1		
123	421298-0	CHECK VALVE		1		
124	266854-7	H.L. BIND BOLT M5X14		3		
125	346722-1	CHAIN CATCHER		1		
126	266856-3	H.L. TAPPING SCREW 5X20		1		
127	454509-8	PUMP COVER		1		
128	266846-6	H.L.BIND BOLT M4X12		1		
129	267047-9	FLAT WASHER 10		1		
130	221427-3	WORM GEAR		1		
131	212129-2	NEEDLE CAGE 1013		1		
132	165725-4	CLUTCH DRUM COMPLETE		1		
133	346693-2	BACK PLATE		1		
134	126348-3	CLUTCH ASSEMBLY		1		
C10	231883-9	TENSION SPRING 8		3		
138	424579-1	OIL PIPE (OUT)		1		
139	142156-4	OIL PUMP COMPLETE		1	*	
139-1	142156-4	OIL PUMP COMPLETE	O	1		
140	266846-6	H.L.BIND BOLT M4X12		1		
141	126349-1	OIL PIPE ASSEMBLY		1		
D10		INC. 117,118				
142	126371-8	CHAIN COVER ASSEMBLY		1	*	
D10		INC. 143-160				
142-1	127248-0	CHAIN COVER ASSEMBLY	<	1	*	
D10		INC. 143-160				
142-2	127248-0	CHAIN COVER ASSEMBLY	O	1		
D10		INC. 143-160				
143	266855-5	H.L. TAPPING SCREW 4X12		5		
144	454515-3	SPRING COVER		1		
145	233607-9	TORSION SPRING 6		1		
146	346702-7	LEVER		1		
147	313265-8	WEIGHT		1		
148	346699-0	GUIDE PLATE CS		1		

149	266166-8	TAPPING SCREW CT 3X8		2		
150	227496-2	STRAIGHT BEVEL GEAR 14		1		
151	326311-8	ADJUST PIN		1		
152	326313-4	ADJUST SCREW		1		
153	227620-7	DRIVE GEAR 14		1		
154	234304-0	COMPRESSION SPRING 7		1		
155	142234-0	LEVER COMPLETE		1		
156-1	143383-6	BRAKE BAND COMPLETE		1		
157	266855-5	H.L. TAPPING SCREW 4X12		2		
158-1	456227-4	CHAIN COVER		1		
159	454620-6	NUT COVER		1		
160-2	144689-5	FLANGE NUT COMPLETE		2	*	
160-3	162493-0	FLANGE NUT COMPLETE	<	2	*	
160-4	162493-0	FLANGE NUT COMPLETE	O	2		
170	142228-5	FRONT GUARD COMPLETE		1		
C10	802E03-8	CAUTION LABEL		1		
171	266857-1	H.L. TAPPING SCREW 5X16		1		
172	346697-4	HOLDER		1		
173	346697-4	HOLDER		1		
174	266857-1	H.L. TAPPING SCREW 5X16		1		
175	266856-3	H.L. TAPPING SCREW 5X20		4		
176	801Y86-5	EA3600F MODEL NO. LABEL		1		
177	126351-4	RECOIL STARTER ASSEMBLY		1		
D10		INC. 178-185				
178	454522-6	STARTER GRIP		1		
179	142237-4	STARTER CASE COMPLETE		1		
180	SG00000020	SPRING ASSEMBLY		1		
181	SG00000025	STARTER ROPE		1		
182	454523-4	REEL		1		
183	SG00000023	DAMPER SPRING		1		
184	454524-2	RATCHET WHEEL		1		
185	266777-9	TAPPING SCREW 5X12		1		
186	142213-8	FAN COVER COMPLETE		1		
187	264094-1	HEX.NUT M8-12 WITH CW		1		
188	142236-6	FLYWHEEL COMPLETE		1		
D10		INC. 189-191				
189	266866-0	H.L.SOCKET HEAD BOLT M5X12		2		
190	346703-5	RATCHET		2		
191	233609-5	TORSION SPRING 15		2		
192	266856-3	H.L. TAPPING SCREW 5X20		1		
193	454493-7	AIR GUIDE PLATE		1		
194	266855-5	H.L. TAPPING SCREW 4X12		1		
195	424574-1	DUMPER STOPPER		1		
196	168508-1	TANK CAP COMPLETE		1		
D10		INC. 202				
197	266854-7	H.L. BIND BOLT M5X14		2		
198	135662-6	ENGINE CASE ASS'Y		1		
D10		INC. 123				
199	234210-9	COMPRESSION SPRING 3		1		
200	313212-9	HAND GUARD GUIDE		1		
201	266856-3	H.L. TAPPING SCREW 5X20		1		
202	213355-6	O-RING 25		1		

203	163518-3	GASOLINE FILTER		1		
204	282020-8	HOSE CLAMP		1		
205	422113-1	OUTER FUEL PIPE		1		
206	422114-9	INNER FUEL PIPE		1		
207	424575-9	GROMMET		1		
208	454508-0	HOSE JOINT		1		
209	424595-3	NEEDLE GUIDE		1		
210	454496-1	SHUTTER PLATE		1		
211	232284-4	LEAF SPRING		2		
212	346696-6	HOOK		2		
215	ZJ00000063	SCREW		1		
216	ZJ00000014	SCREW (WITH SERRATION)		2		
217	ZJ00000055	COVER, METERING		1		
218	ZJ00000058	DIAPHRAGM ASS'Y, METERING		1		
219	ZJ00000011	GASKET, METERING CHAMBER		1		
220	ZJ00000006	LEVER		1		
221	ZJ00000009	SCREW (METERING LEVER PIN)		1		
222	ZJ00000008	PIN		1		
223	ZJ00000010	SPRING, METERING LEVER		1		
224	ZJ00000007	VALVE, INLET NEEDLE		1		
225	ZJ00000048	LEVER, CHOKE		1		
226	ZJ00000003	STRAINER		1		
227	ZJ00000029	DIAPHRAGM, PUMP		1		
228	ZJ00000016	GASKET, PUMP		1		
229	ZJ00000056	COVER, PUMP		1		
230	ZJ00000020	SCREW (PUMP COVER)		1		
231	ZJ00000051	SCREW, MAIN MIXTURE		1		
232	ZJ00000050	SCREW, IDLE MIXTURE		1		
233	ZJ00000074	PLUNGER		1		
234	ZJ00000054	O-RING		1		
235	ZJ00000073	SPRING		1		
237	ZJ00000061	SCREW, THROTTLE ADJUST		1		
238	ZJ00000068	SPRING, ADJUST SCREW		1		
239	ZJ00000075	AIR HEAD KIT		1		
240	ZJ00000076	GASKET AND DIAPHRAGM KIT		1		
D10		INC. 218,219,227,228				
A01	165201-8	GUIDE BAR 14		1	*	
A01-1	165201-8	GUIDE BAR 14	O	1		
A02	419559-0	CHAIN PROTECTION COVER 330		1		
A03	782027-9	BOX WRENCH		1		
A04	196207-5	SAW CHAIN SET		1		
E01	347558-1	HEAT PROTECTION FOIL	S	1		

Please state Parts No. when your order.

Print Date 18/10/2023