

Model No.EA6100P PETROL CHAIN SAW

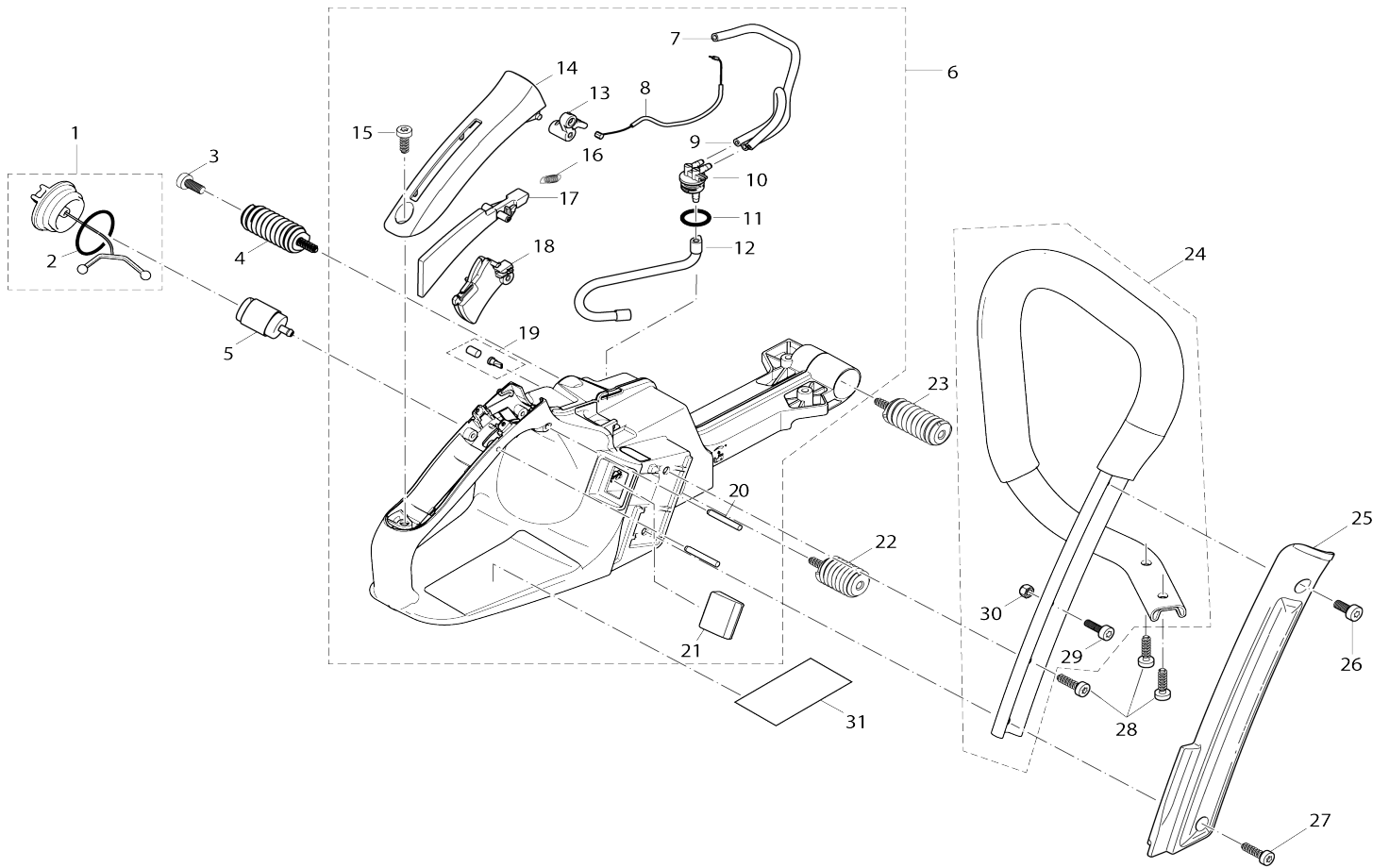

Model No.EA6100P PETROL CHAIN SAW

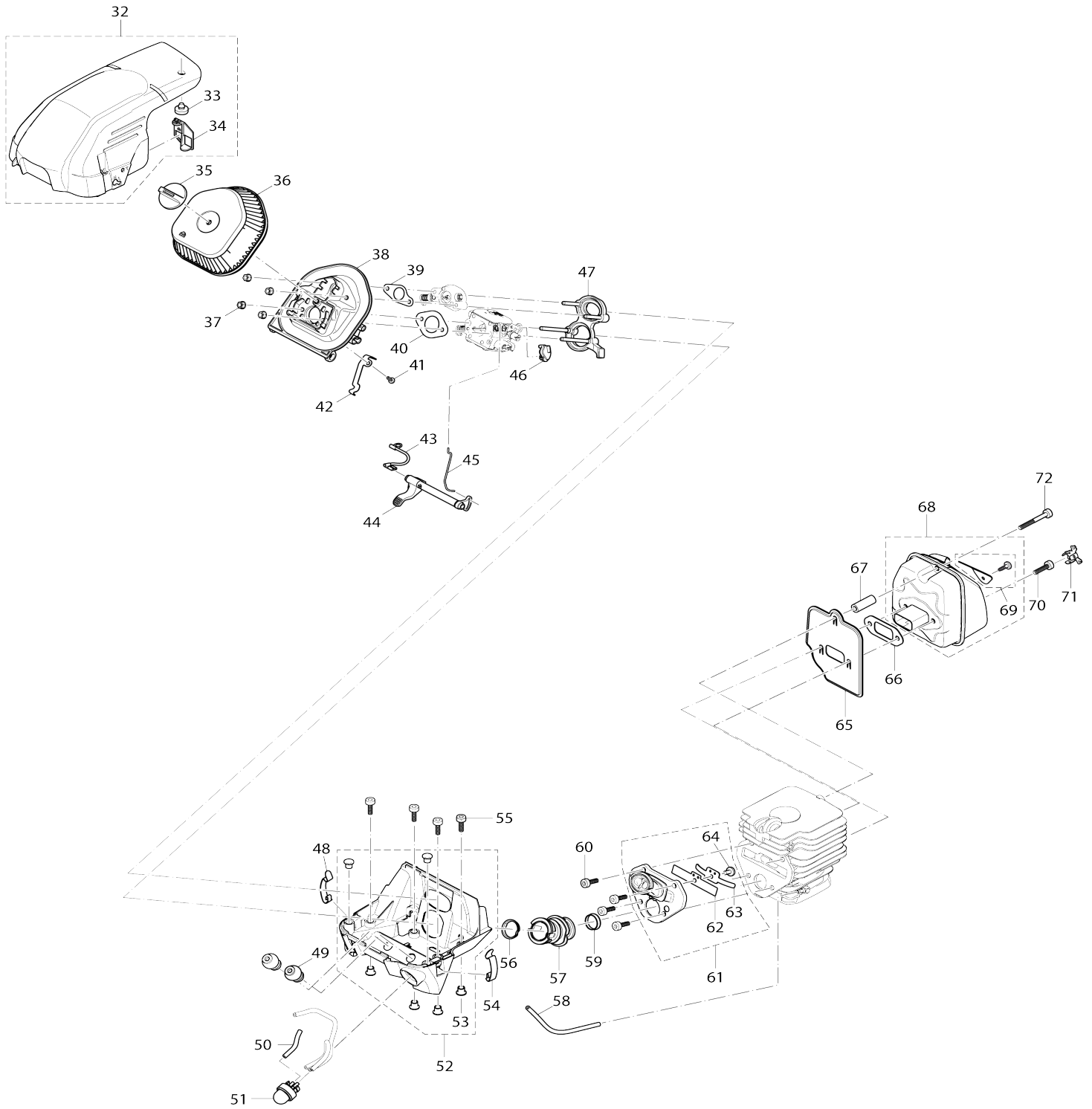

Model No.EA6100P PETROL CHAIN SAW

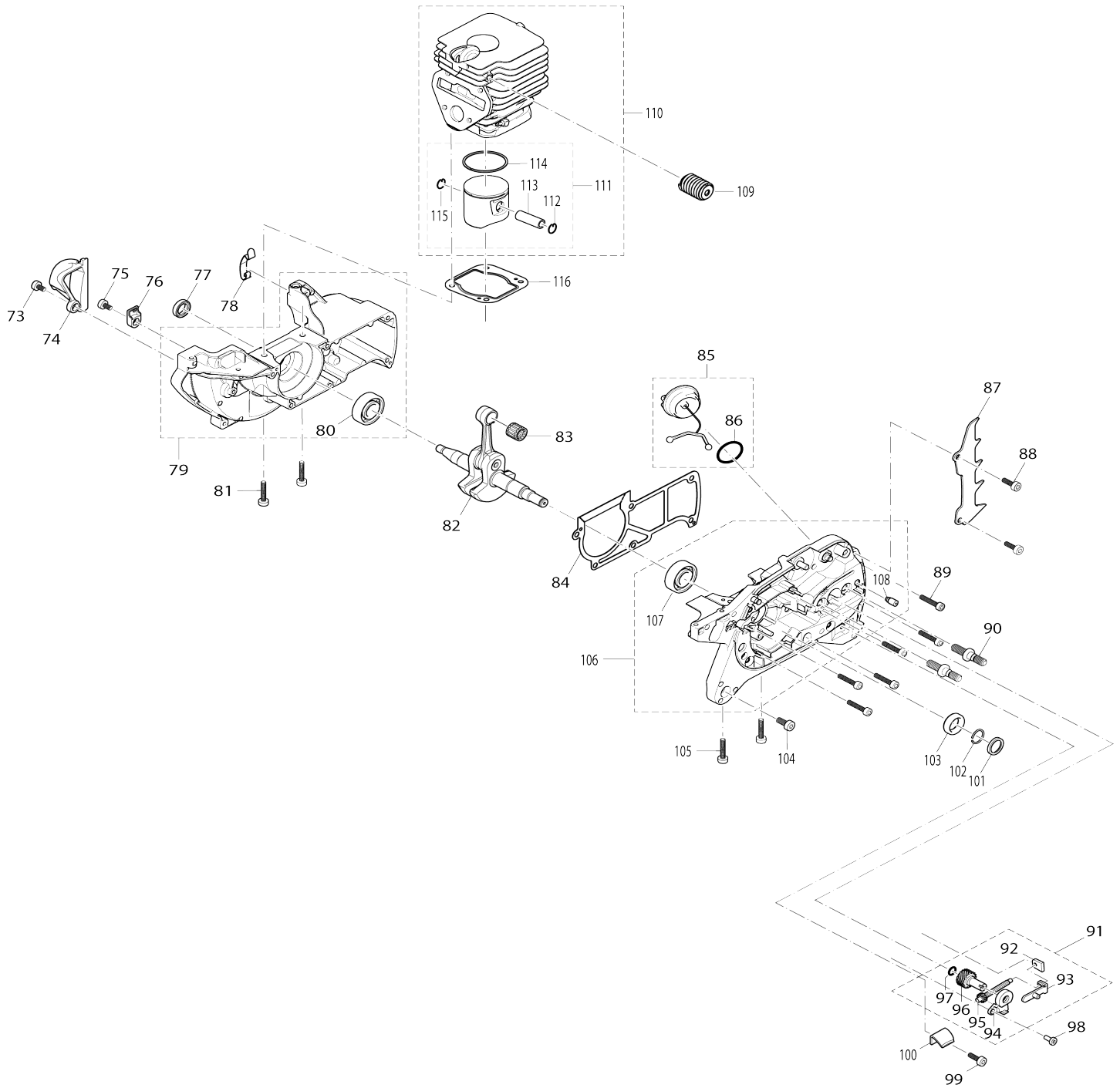

Model No.EA6100P PETROL CHAIN SAW

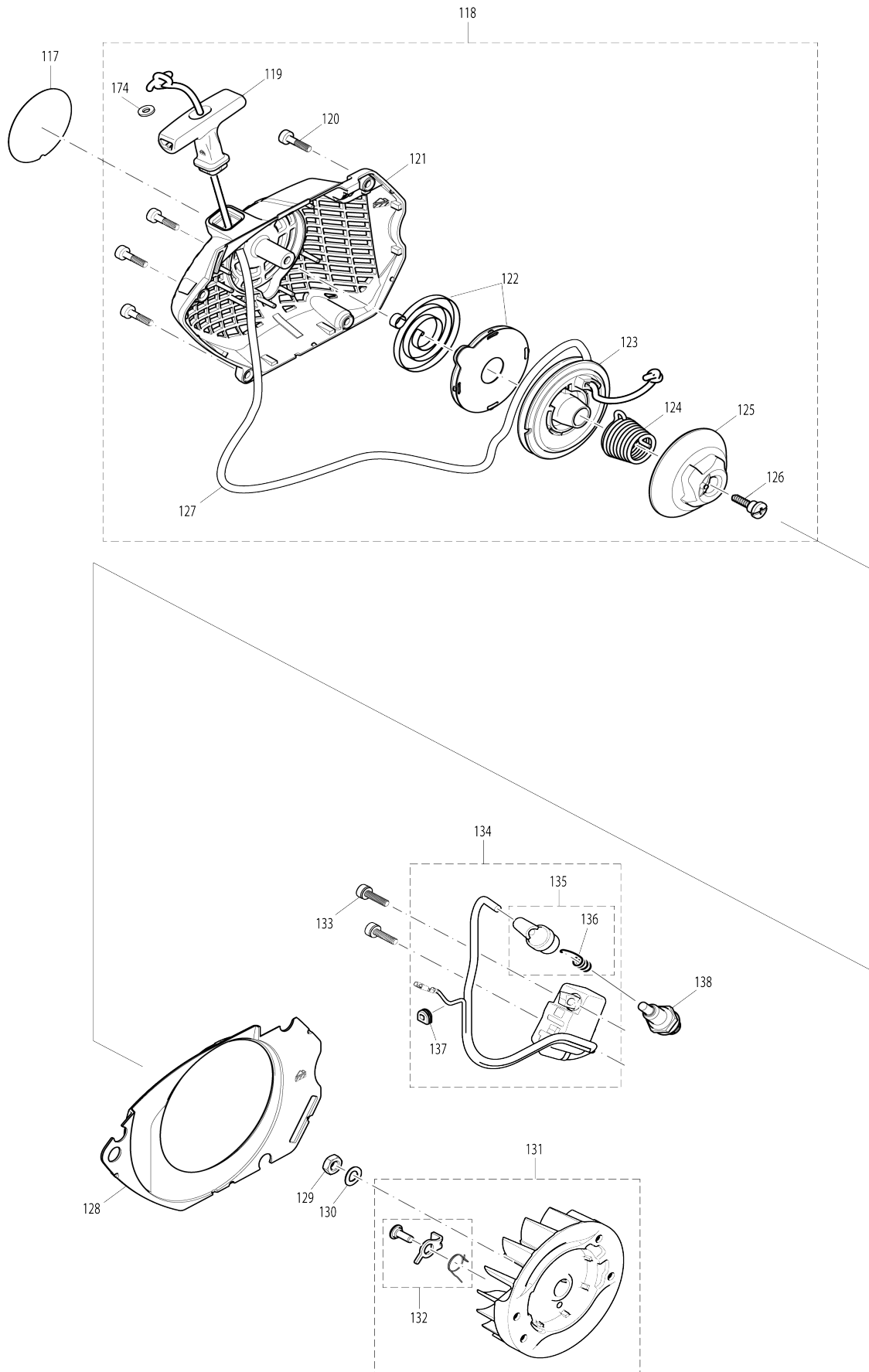

Model No.EA6100P PETROL CHAIN SAW

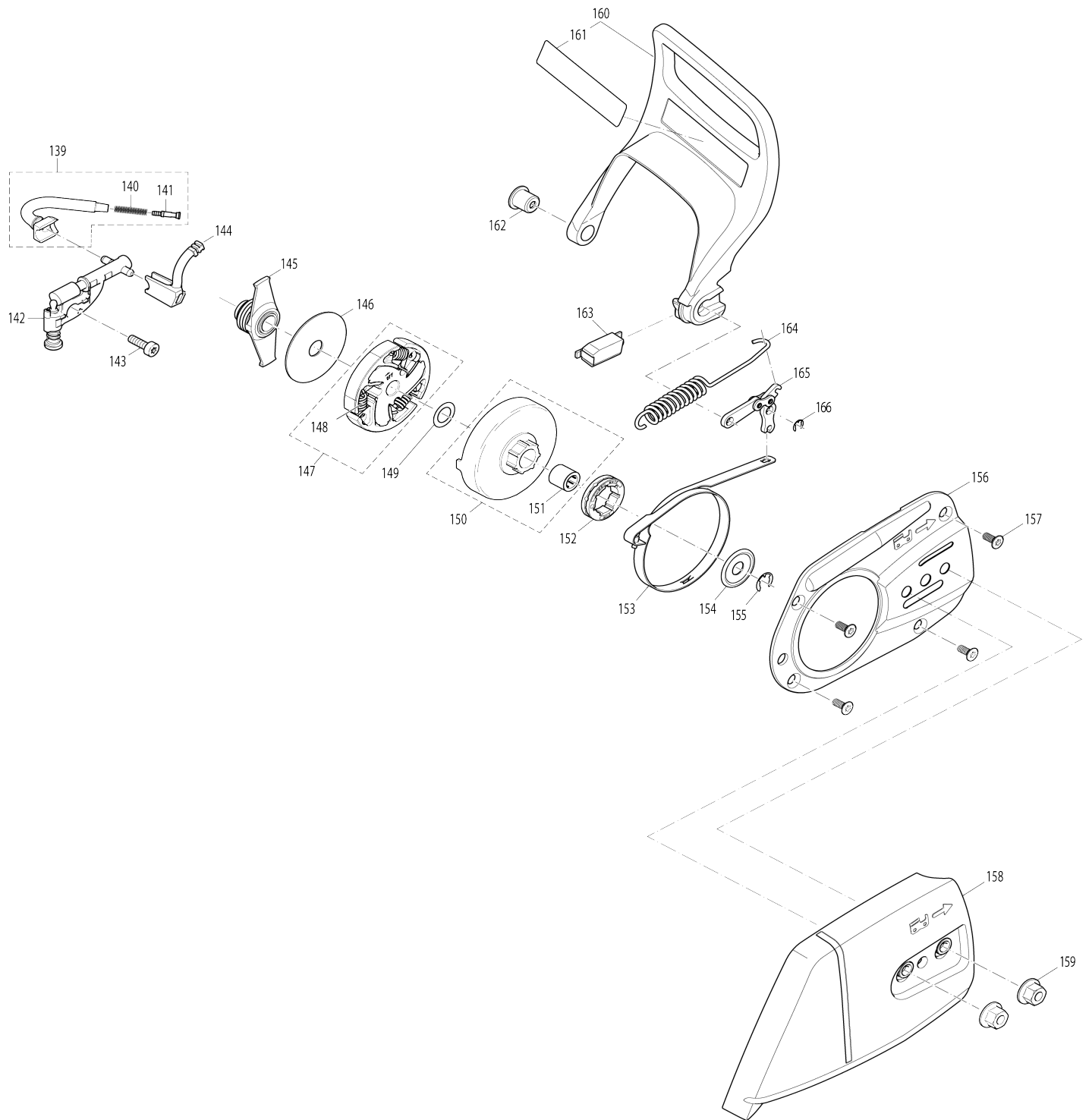

Model No.EA6100P PETROL CHAIN SAW

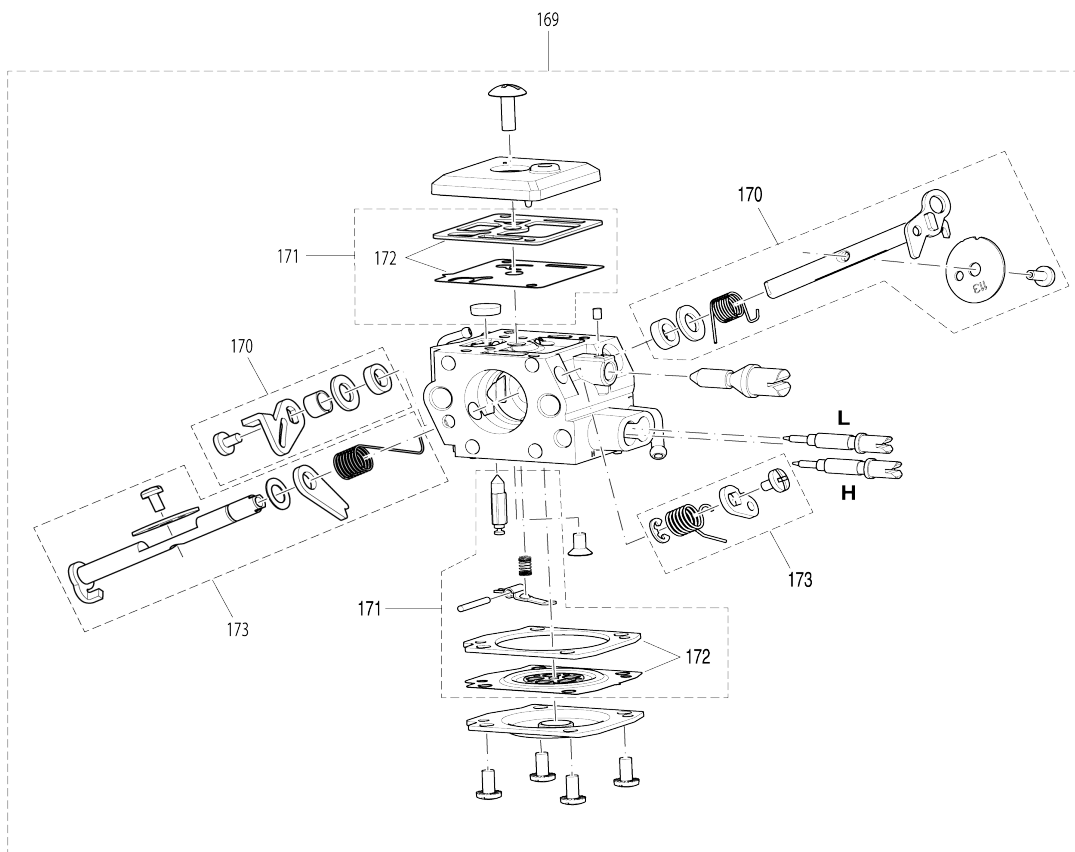
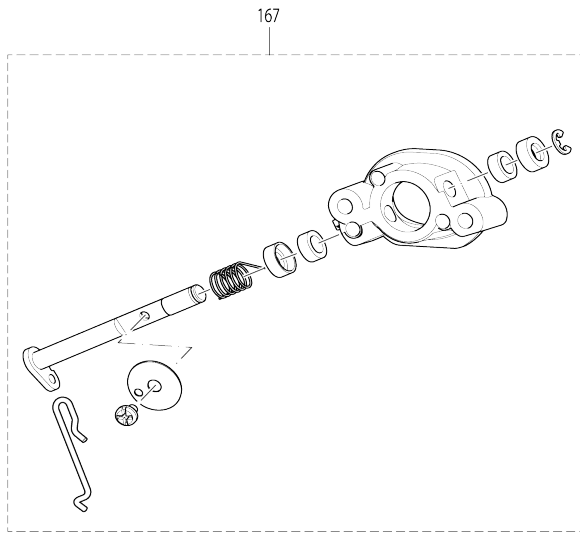

Model No.EA6100P PETROL CHAIN SAW

Item No.	Parts No.	Description	Interchangability	Q'ty	New/Old	Note1	Note2
001	181114202	TANK CAP CPL.		1	*		
D10		INC. 2					
001-1	168507-3	TANK CAP COMPLETE	O	1			
D10		INC. 2					
002	963229036	PACKING RING		1	*		
002-1	213080-9	O RING 29.5	O	1			
003	908006145	H.L. SOCKET HEAD BOLT M6X14		1			
004	181114301	DAMPING SPRING, CPL.		1			
C10	010114020	REP.KIT, FILTER(FELT ELEMENT)		1	*		
005	010114010	SUCTION HEAD(FUEL)		1	*		
C10	010114020	REP.KIT, FILTER(FELT ELEMENT)		1	*		
005-1	163499-1	SUCTION HEAD	O	1			
006	130114600	TANK CPL. BLUE		1			
D10		INC. 7-21					
007	965452660	FUEL TUBE 3MM RED (L=1M)		1			
008	130117040	THROTTLE CONTROL CABLE		1			
009	965452090	FUEL TUBE 2.5MM (L=1M)		1	*		
009-1	424755-7	TUBE 2.5-93	O	1			
010	195114060	NIPPLE		1			
011	963211020	O RING		1			
012	130114050	FUEL LINE		1			
013	038117030	ROCKER		1			
014	130117050	GRIP OUTER SHELL		1			
015	913455164	H.L. TAPPING SCREW 5.5X16		1	*		
015-1	266478-9	H.L.TAPPING SCREW 5.5X16	O	1			
016	130117060	TENSION SPRING		1			
017	038117020	CATCH LEVER		1			
018	130117010	THROTTLE LEVER		1			
019	170175010	AIR VALVE COMPLETE		1	*		
019-1	195762-4	AIR VALVE SET	O	1			
020	935930280	CYLINDRICAL PIN 3X28		2	*		
020-1	268335-7	PIN 3	O	2			
021	130148650	COVER HANDLE HEATING		1			
022	130114400	DAMPING SPRING CPL.		1			
023	181114301	DAMPING SPRING, CPL.		1			
024	130310100	FRONT HANDLE ASSY		1	*		
D10		INC. 29,30					
024-1	140G05-1	TUBULAR HANDLE CPL.	O	1			
D10		INC. 29,30					
025	130310850	HANDLE COVER MAKITA BLACK		1			
026	130310650	HANDLE COVER MAKITA BLUE		1	*		
026-1	908006145	H.L. SOCKET HEAD BOLT M6X14	X	1			
027	913455204	H.L.TAPPING SCREW 5.5X20		1	*		
027-1	913455204	H.L.TAPPING SCREW 5.5X20	O	1	*		
027-2	266475-5	H.L.TAPPING SCREW 5.5X20	O	1			
028	913455204	H.L.TAPPING SCREW 5.5X20		3	*		
028-1	913455204	H.L.TAPPING SCREW 5.5X20	O	3	*		

028-2	266475-5	H.L.TAPPING SCREW 5.5X20	O	3		
029	908005165	FILLISTER HEAD SCREW M5X16		1	*	
029-1	266605-8	H.L. SOCKET HEAD BOLT M5X16	O	1		
030	920405000	HEX. NUT M5		1	*	
030-1	252238-5	HEX. LOCK NUT M5-8	O	1		
032	130118600	AIR FILTER ELEMENT COVER		1		
D10		INC. 33,34				
033	965402360	RUBBER BUFFER		1	*	
033-1	424878-1	BUFFER	O	1		
034	130118140	ANTI ICING PLATE		1		
035	130173060	CLAMPING BOLT		1		
036	130173010	AIR FILTER ELEMENT		1		
037	175131300	HEX. FLANGE NUT M4		4	*	
037-1	264119-1	HEXAGONAL NUT M4	O	4		
038	130171010	INTAKE MANIFOLD		1	*	
038-1	130171011	INTAKE MANIFOLD	O	1		
039	315155010	GASKET AIR VALVE		1	*	
039-1	346955-8	GASKET AIR VALVE	O	1		
040	315155020	GASKET INTAKE MANIFOLD		1	*	
040-1	346956-6	GASKET INTAKE MANIFOLD	O	1		
041	915735100	PZ2 TAPPING SCREW 3.5X9.5		1	*	
041-1	251533-0	TAPPING SCREW 3.5X10	O	1		
042	130155010	CONTACT SPRING		1		
043	130147020	EARTH CABLE		1		
044	130155020	CHOKE LEVER		1		
045	130155040	CHOKE SHAFT		1		
046	175155082	THROTTLE CONTROL CABLE FIXTURE		1		
047	130131070	FLANGE RING		1		
048	130118070	STEELCLIP		1	*	
048-1	347071-9	CLAMP	O	1		
049	038171030	HOLDER		2		
050	965452090	FUEL TUBE 2.5MM (L=1M)		1	*	
050-1	424755-7	TUBE 2.5-93	O	1		
051	130153500	PRIMER		1		
052	130131600	CARBURETOR HOUSING BLUE ASSY		1		
D10		INC. 53				
053	001118100	BUSHING		6	*	
053-1	326780-3	BUSH	O	6		
054	130118070	STEELCLIP		1	*	
054-1	347071-9	CLAMP	O	1		
055	908005165	FILLISTER HEAD SCREW M5X16		4	*	
055-1	266605-8	H.L. SOCKET HEAD BOLT M5X16	O	4		
056	130131020	INSERT FOR SUCTION HOSE		1		
057	130131031	INTAKE HOSE		1	*	
057-1	130131032	SUCTION HOSE	O	1		
058	965452090	FUEL TUBE 2.5MM (L=1M)		1	*	
058-1	424755-7	TUBE 2.5-93	O	1		
059	130131050	INSERT		1		
060	908405145	H.L. SOCKET HEAD BOLT M5X14		4	*	
060-1	266986-0	H.L. SOCKET HEAD BOLT M5X14	O	4		

061	130131160	AIR HOSE CPL.		1	*		
D10		INC. 62-64					
061-1	130131161	AIR HOSE COMPLETE	O	1	*		
D10		INC. 62-64					
061-2	130131162	AIR HOSE COMPLETE	O	1			
D10		INC. 62-64					
062	315179021	LEAD VALVE		1	*		
062-1	346951-6	REEDVALVE	O	1			
063	315179010	VALVE STOPPER		1	*		
063-1	310674-2	VALVE STOPPER	O	1			
064	908004085	H.L. SOCKET HEAD BOLT M4X8		1	*		
064-1	908004085	H.L. SOCKET HEAD BOLT M4X8	O	1	*		
064-2	266985-2	H.L. SOCKET HEAD BOLT M4X8	O	1			
065	130174090	HEAT INSULATION PLATE		1			
066	395174120	MUFFLER GASKET		1	*		
066-1	346876-4	MUFFLER GASKET	O	1			
067	038174030	SLEEVE 5 L=26.8MM		1	*		
067-1	325939-9	CONNECTING LINK	O	1			
068	130174100	MUFFLER CPL.		1	*		
D10		INC. 69					
068-1	161513-7	MUFFLER CPL	O	1			
D10		INC. 69					
069	130174150	SPARK ARRESTER SCREEN CPL.		1			
070	908005205	H.L. SOCKET HEAD BOLT M5X20		2	*		
070-1	266476-3	H.L. SOCKET HEAD BOLT M5X20	O	2	*		
070-2	266476-3	H.L. SOCKET HEAD BOLT M5X20	O	2			
071	038174451	PLUG FOR MUFFLER TUBE		2			
072	908305405	H.L. SOCKET HEAD BOLT M5X40		1	*		
072-1	266943-8	H.L. SOCKET HEAD BOLT M5X40	O	1			
073	908005095	H.L. SOCKET HEAD BOLT M5X9		1	*		
073-1	266474-7	H.L. SOCKET HEAD BOLT M5X9	O	1			
074	130173080	SUCTION PIPE		1			
075	908005095	H.L. SOCKET HEAD BOLT M5X9		1	*		
075-1	266474-7	H.L. SOCKET HEAD BOLT M5X9	O	1			
076	130111090	CLAMP		1			
077	962900052	OIL SEAL		1	*		
077-1	213814-0	RADIAL RING	O	1			
078	130118070	STEELCLIP		1	*		
078-1	347071-9	CLAMP	O	1			
079	130111620	CRANKCASE ASSY-LEFT SIDE BLUE		1	*		
D10		INC. 80					
079-1	140R07-3	CRANKCASE MS BLUE COMPLETE	O	1			
D10		INC. 80					
080	960102152	BALL BEARING 6202		1	*		
080-1	211154-0	BALL BEARING 6202	O	1			
081	908005255	H.L. SOCKET HEAD BOLT M5X25		2	*		
081-1	266984-4	H.L. SOCKET HEAD BOLT M5X25	O	2			
082	130120102	CRANKSHAFT COMPLETE		1	*		
082-1	143709-2	CRANKSHAFT CPL.	<	1			
083	962210111	NEEDLE CAGE		1	*		
083-1	962210111	NEEDLE CAGE	O	1	*		

083-2	212164-0	NEEDLE CAGE	O	1		
084	130111070	CRANK CASE GASKET		1		
085	168507-3	TANK CAP COMPLETE		1		
D10		INC. 86				
086	213080-9	O RING 29.5		1		
087	130250010	SPIKE BAR		1		
088	908005165	FILLISTER HEAD SCREW M5X16		2	*	
088-1	266605-8	H.L. SOCKET HEAD BOLT M5X16	O	2		
089	908405255	H.L. SOCKET HEAD BOLT M5X25		6	*	
089-1	266880-6	H.L. SOCKET HEAD BOLT M5X25	O	6		
090	195232010	GUIDE BAR BOLT M8		2	*	
090-1	266978-9	BOLT	O	2		
091	130213150	CHAIN TENSIONER CPL.		1	*	
D10		INC. 92-97				
091-1	130213160	CHAIN TENSIONER CPL.	O	1		
D10		INC. 92-97				
092	181213260	TENSIONING SCREW BEARING		1		
093	130213240	TENSION SLIDE		1	*	
093-1	130213250	TENSION SLIDE	O	1	*	
093-2	130213251	TENSION SLIDE	O	1		
094	181213270	TRANSMISSION COVER		1	*	
094-1	185213270	TRANSMISSION COVER	O	1	*	
094-2	452667-4	GEAR COVER PROFESSIONAL	O	1		
095	181213230	TENSIONING SCREW		1	*	
095-1	227743-1	HELICAL GEAR 11	O	1		
096	181213250	ADJUSTING SCREW		1	*	
096-1	227744-9	HELICAL GEAR 18	O	1		
097	963207020	O RING		1		
098	908705125	H.L. SOCKET HEAD BOLT M5X12		1	*	
098-1	266484-4	H.L. SOCKET HEAD BOLT M5X12	O	1		
099	908006145	H.L. SOCKET HEAD BOLT M6X14		1		
100	181111050	CHAIN CATCH		1	*	
100-1	181111051	CHAIN CATCH	O	1		
101	394245010	STOP RING		1	*	
101-1	346872-2	STOP RING	O	1		
102	930916160	SPRING RING		1	*	
102-1	234366-8	SNAP RING A 16	O	1		
103	962900052	OIL SEAL		1	*	
103-1	213814-0	RADIAL RING	O	1		
104	908006145	H.L. SOCKET HEAD BOLT M6X14		1		
105	908005255	H.L. SOCKET HEAD BOLT M5X25		1	*	
105-1	266984-4	H.L. SOCKET HEAD BOLT M5X25	O	1		
106	130111610	CRANKCASE ASSY-RIGHT SIDE BLUE		1	*	
D10		INC. 107,108				
106-1	140R06-5	CRANKCASE CS BLUE COMPLETE	O	1		
D10		INC. 107,108				
107	960102152	BALL BEARING 6202		1	*	
107-1	211154-0	BALL BEARING 6202	O	1		
108	010245030	VENT VALVE		1	*	
108-1	168504-9	VENT VALVE	O	1		
109	181114401	DAMPING SPRING,CPL.		1		

110	130131150	CYLINDER 47 & PISTON SET		1		
D10		INC. 111				
111	315132101	PISTON & PISTON RING, PIN SET		1	*	
D10		INC. 112-115				
111-1	191L97-3	PISTON SET	O	1		
D10		INC. 112-115				
112	315132040	CIRCLIP		1	*	
112-1	234390-1	CIRCLIP 11	O	1		
113	315132050	PISTON PIN		1	*	
113-1	257846-7	PISTON PIN	O	1		
114	315132020	PISTON RING		1	*	
114-1	257384-9	PISTON RING D47	O	1		
115	315132040	CIRCLIP		1	*	
115-1	234390-1	CIRCLIP 11	O	1		
116	315131020	GASKET		1	*	
116-1	346950-8	CYLINDERBASE GASKET	O	1		
117	980115856	LABEL EA6100P		1		
118	130160600	STARTER ASSY BLUE		1	*	
D10		INC. 119-127				
118-1	130160602	STARTER ASSY BLUE	O	1	*	
D10		INC. 119-127				
D11		INC. 119,120,122-127,174				
118-2	144002-7	STARTING DEVICE CPL	O	1		
D11		INC. 119,120,122-127,174				
119	181164010	STARTER GRIP		1	*	
119-1	452458-3	STARTER GRIP	O	1		
120	908005205	H.L. SOCKET HEAD BOLT M5X20		4	*	
120-1	266476-3	H.L. SOCKET HEAD BOLT M5X20	O	4	*	
120-2	266476-3	H.L. SOCKET HEAD BOLT M5X20	O	4		
121	130160630	STARTER HOUSING ASSY BLUE		1	*	
121-1	130160631	STARTER HOUSING ASSY BLUE	O	1	*	
122	181163050	REWIND SPRING IN HOUSING		1	*	
122-1	140587-1	REWIND SPRING COMPLETE	O	1		
123	315162020	CABLE DRUM		1	*	
123-1	456308-4	CABLE DRUM	O	1		
124	181163080	SPRING EASY-START		1	*	
124-1	234193-3	SPRING EASY START	O	1		
125	315163090	STARTER RATCHET WHEEL		1	*	
125-1	456309-2	DRIVER EASY START	O	1		
126	181163095	STEPPED TAPPING SCREW 5X16.5		1	*	
126-1	266616-3	SCREW	O	1		
127	181164020	STARTER ROPE 3.5MM (L=1M)		1	*	
127-1	444022-4	STARTER ROPE	O	1		
128	130118040	AIR GUIDE PLATE		1		
129	920308024	HEX. NUT M8X1 (FINE THREAD)		1	*	
129-1	264022-6	HEX. NUT M8X1	O	1		
130	926208001	SPRING WASHER 8		1	*	
130-1	267822-3	SPRING WASHER 8	O	1		
131	130141100	FLYWHEEL CPL.		1	*	
D10		INC. 132				
131-1	143704-2	FLYWHEEL CPL	<	1		

C10	347384-8	RATCHET		2		
C20	232455-3	TORSION SPRING 13		2		
C30	266626-0	H.L. TAPPING SCREW 5X12		2		
132	130141150	STARTER RATCHET & SPRING SET		2	*	
133	908805205	H.L. SOCKET HEAD BOLT M5X20		2	*	
133-1	266472-1	TORX SOCKET HEAD BOLT M5X20	O	2		
134	130143100	IGNITION COIL COMPLETE		1	*	
D10		INC. 135,137				
134-1	130143101	IGNITION COIL COMPLETE	O	1		
D10		INC. 135,137				
135	957604260	PLUG CAP COMPLETE		1		
D10		INC. 136				
136	965604180	PLUG CAP SPRING		1	*	
136-1	234358-7	TERMINAL SPRING	O	1		
137	965401016	SEMI-CYLINDRICAL GROMMET		1	*	
137-1	424696-7	RUBBER GROMMET	O	1		
138	965603021	SPARK PLUG BPMR7A		1	*	
138-1	168648-5	SPARK PLUG (BPMR7A)	O	1		
139	181245100	OIL LINE CPL.		1		
D10		INC. 140,141				
140	021245060	PRESSURE SPRING		1	*	
140-1	231975-4	SPRING	O	1		
141	001245020	HOSE STEM		1		
142	179245201	OIL PUMP CPL.		1	*	
142-1	179245202	OIL PUMP CPL.	O	1	*	
142-2	179245204	OIL PUMP CPL.	O	1	*	
142-3	161346-0	OIL PUMP COMPLETE	O	1		
143	908705125	H.L. SOCKET HEAD BOLT M5X12		1	*	
143-1	266484-4	H.L SOCKET HEAD BOLT M5X12	O	1		
144	181245120	OIL LINE		1	*	
144-1	424178-9	OIL TUBE	O	1		
145	181245090	PUMP DRIVE		1	*	
145-1	450956-1	PUMP DRIVE	O	1		
146	001182042	DISC		1	*	
146-1	267389-1	FLAT WASHER 12	O	1		
147	175180101	CLUTCH ASSY.		1	*	
D10		INC. 148				
147-1	181180300	CLUTCH ASSY	O	1	*	
D10		INC. 148				
147-2	127443-2	CLUTCH ASSEMBLY	O	1		
D10		INC. 148				
148	024184021	TENSION SPRING		3	*	
148-1	181184020	TENSION SPRING	O	3	*	
148-2	232352-3	TENSION SPRING 6	O	3		
149	181224090	FLAT WASHER 10		1	*	
149-1	181224090	FLAT WASHER 10	O	1		
150	181223062	CLUTCH DRUM CPL.		1	*	
D10		INC. 151				
150-1	181223200	CLUTCH DRUM COMPLETE	O	1	*	
D10		INC. 151				
150-2	144765-5	CLUTCH DRUM COMPLETE	O	1		

D10		INC. 151				
151	962300009	NEEDLE BEARING		1	*	
151-1	212082-2	NEEDLE BEARING 1012	O	1		
152	181224040	RIM SPROCKET .325" SM7-7		1		
153	181213011	BRAKE BAND		1	*	
153-1	346029-5	BRAKE BAND	O	1		
154	181224081	WASHER 29		1	*	
154-1	267820-7	WASHER 29	O	1		
155	927408000	STOP RING E-8		1	*	
155-1	259045-7	STOP RING E-8	O	1		
156	130213190	CHAIN BRAKE COVER		1	*	
156-1	130213191		O	1		
157	908105124	H.L.S. FLAT HEAD BOLT M5X12		4		
158	130213600	SPROCKET GUARD CPL.		1		
159	923208004	HEX. FLANGE NUT M8(BAR NUT)		2	*	
159-1	252145-2	COLLARED HEX NUT M8	O	2		
160	130213200	HAND GUARD CPL.		1		
D10		INC. 161				
161	185114237	LABEL		1	*	
161-1	810449-4	CAUTION LABEL	O	1	*	
161-2	818N32-5	CAUTION LABEL	<	1		
162	181213320	BUSHING		1	*	
162-1	325604-0	BUSH	O	1		
163	181213170	HANDGUARD GUIDE,CPL.		1	*	
163-1	450926-0	STOPPER CASE	O	1		
164	181213023	TENSION SPRING		1	*	
164-1	231870-8	TENSION SPRING 10	O	1		
165	181213100	BRAKING MECHANISM		1	*	
165-1	163500-2	LINK PLATE COMPLETE	O	1		
166	927304000	STOP RING E-4		1	*	
166-1	257934-0	STOP RING E-4	O	1		
167	130153700	AIR FLAP CPL.		1	*	
D10		INC. 168				
167-1	143441-8	AIR HEAD COMPLETE	O	1		
169	130153100	CARBURETOR		1		
D10		INC. 170,171,173				
170	130153150	THROTTLE KIT		1	*	
170-1	130153150	THROTTLE KIT	O	1		
171	130153130	REPAIR KIT		1		
172	315153690	GASKET & DIAPHRAGM KIT		1	*	
172-1	315153691	GASKET & DIAPHRAGM KIT	<	1	*	
172-2	130153140	GASKET & DIAPHRAGM KIT	<	1		
173	130153160	CHOKE KIT		1		
174	928405000	SPRING WASHER 5		1	*	
174-1	928405000	SPRING WASHER 5	O	1	*	
174-2	267821-5	SPRING WASHER 5	O	1		
A01	528099664	SAW CHAIN 3/8" .058" L64 FC MB		1		
A02	443045651	GUIDE BAR STD 18"3/8".058" M		1	*	
A02-1	445045651	GUIDE BAR STD 18"3/8".058" M	O	1	*	
A02-2	162832-4	GUIDE BAR 18	O	1		
A03	952020650	BAR COVER 18-20"45-50CM MAKI TA		1		

A04	941719131	UNIVERSAL WRENCH		1	*		
A04-1	941719133	UNIVERSAL WRENCH 13/19	O	1	*		
A04-2	782033-4	UNIVERSAL WRENCH 13/19	O	1			
A05	940827000	HEXALOBULAR ANGLED DRIVER T27		1	*		
A05-1	782025-3	HEXALOBULAR WRENCH 27	O	1			
A06	944340001	SCREW DRIVER		1	*		
A06-1	783012-5	SCREWDRIVER	O	1			
A07	950004002	PLASTIC BAG		1	*		
A07-1	831340-3	TOOL BAG	O	1			

Please state Parts No. when your order.

Print Date 18/10/2023