

Model No.EN4951SH PETROL POLE HEDGE TRIMMER

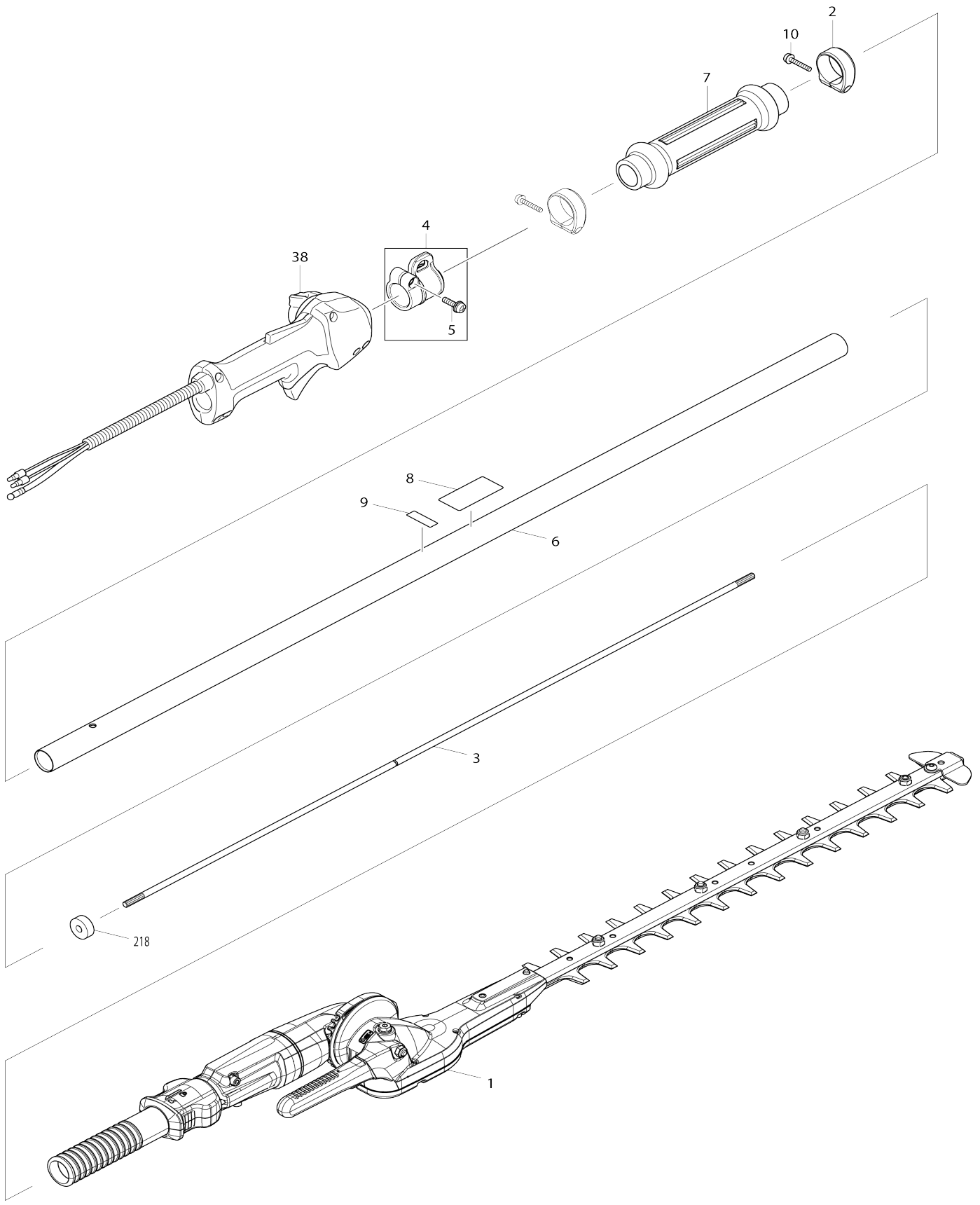

Model No.EN4951SH PETROL POLE HEDGE TRIMMER

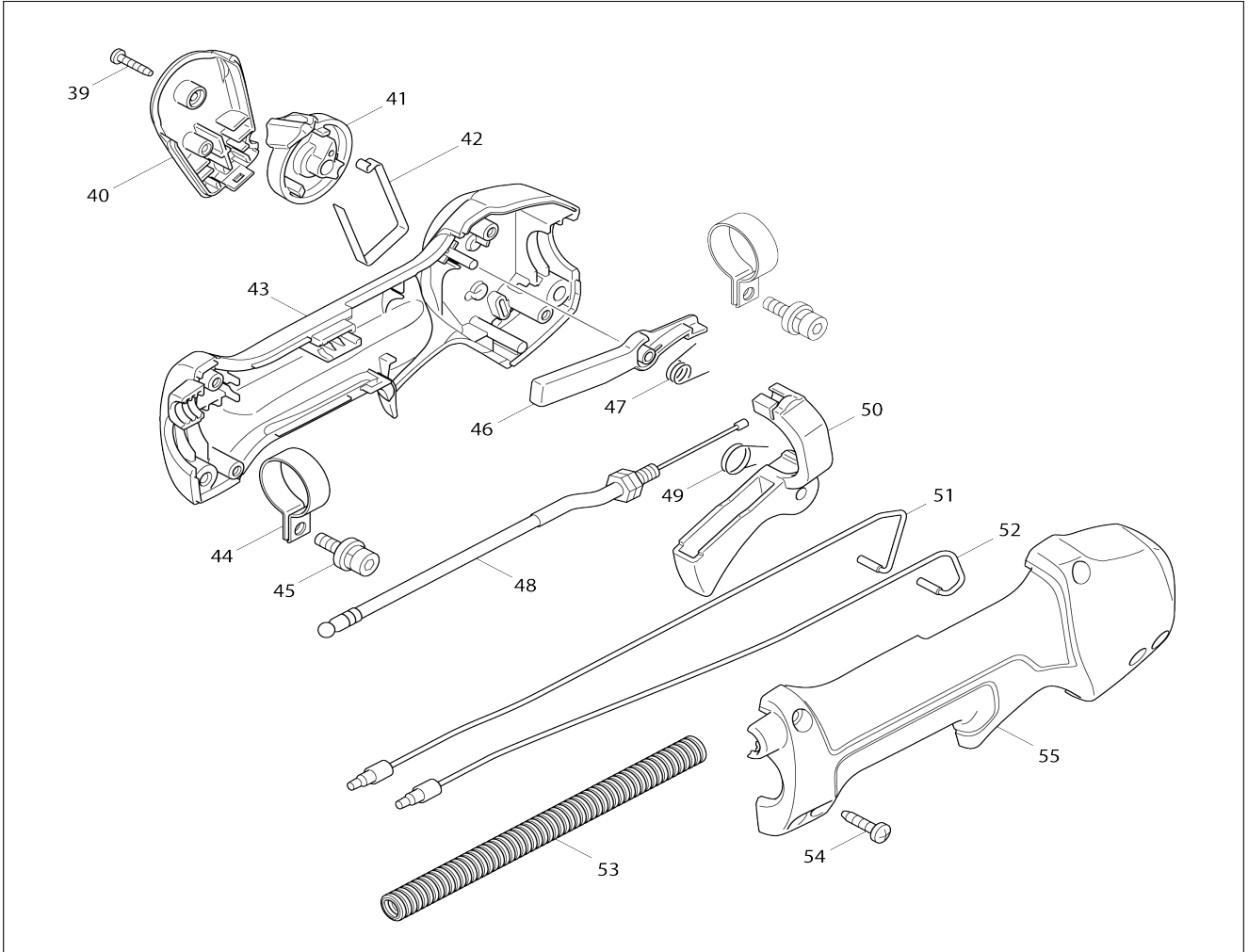

324

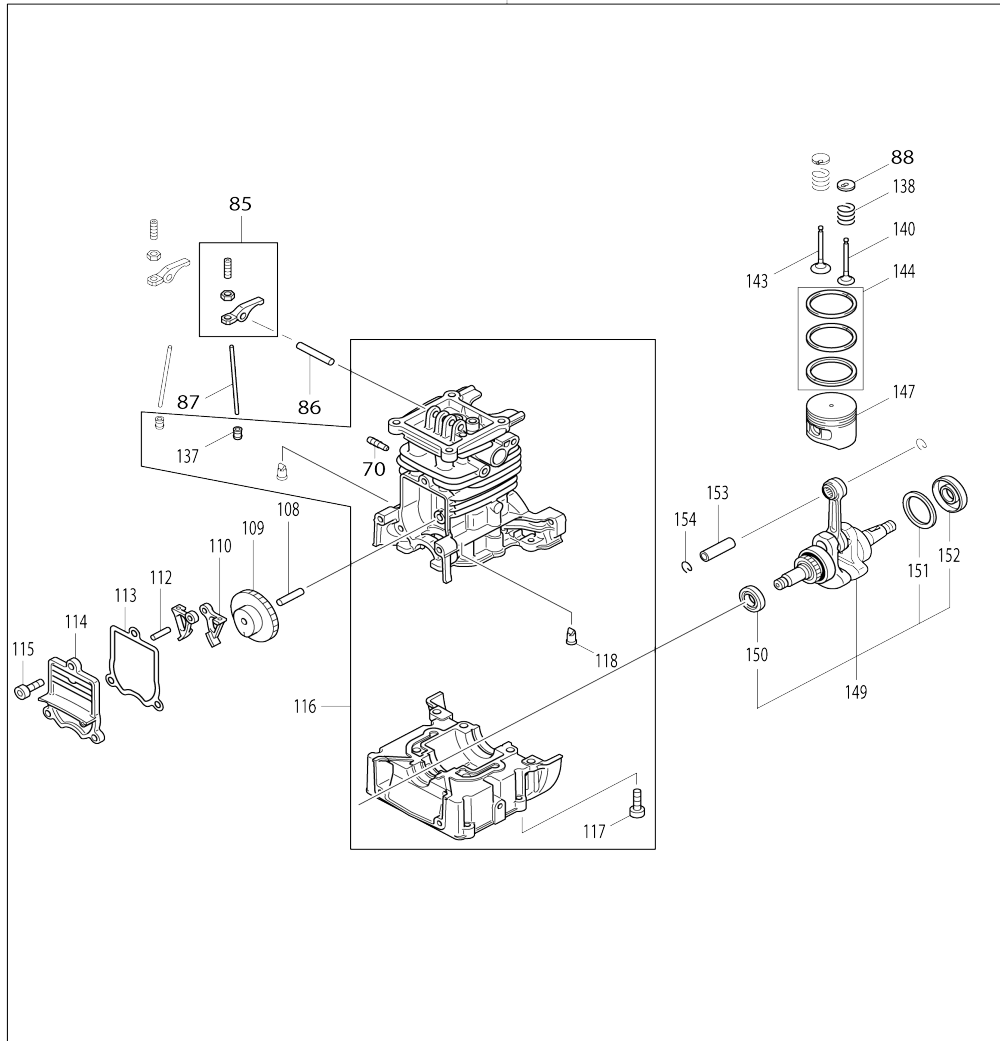

197

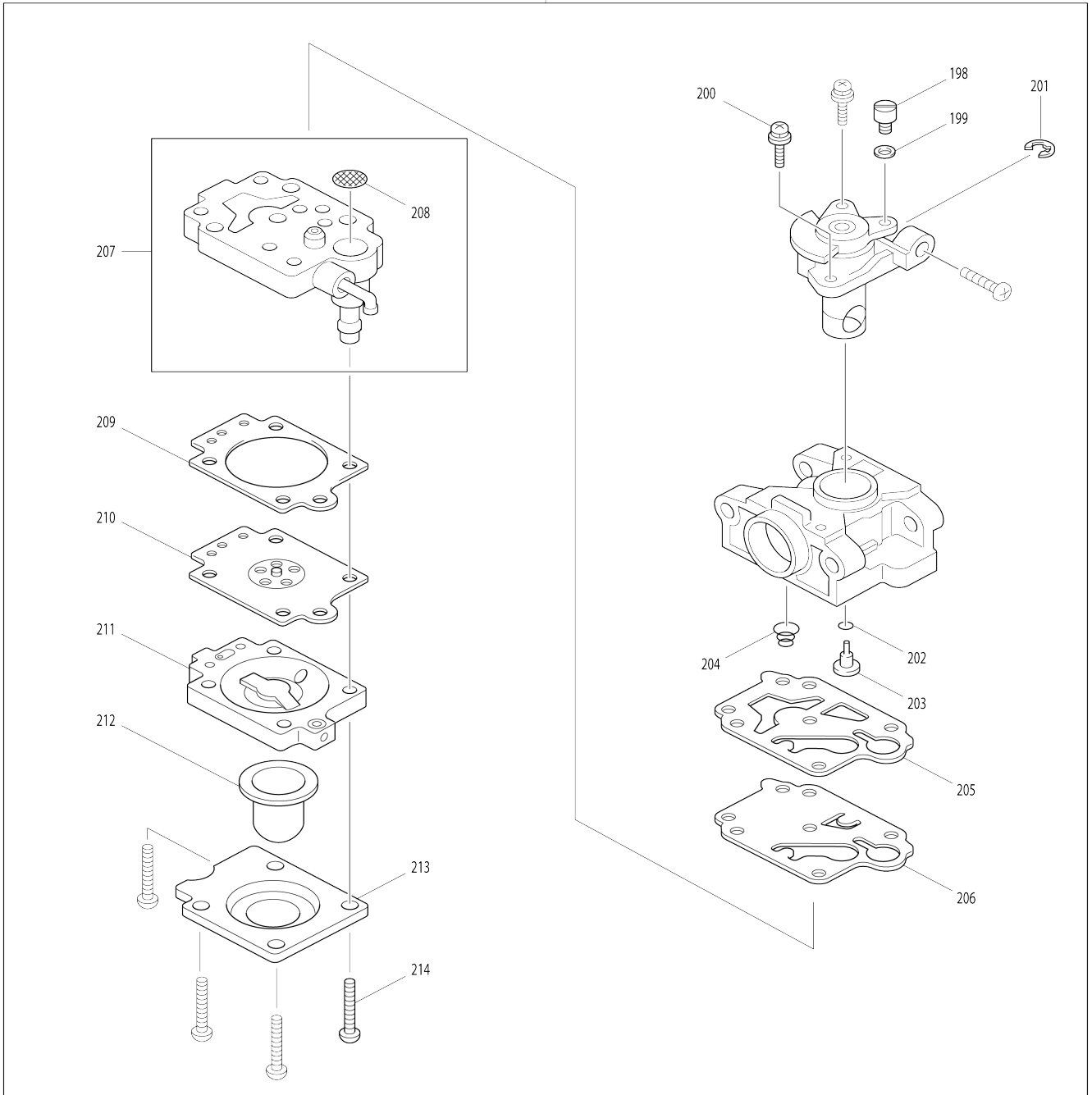

Model No.EN4951SH PETROL POLE HEDGE TRIMMER

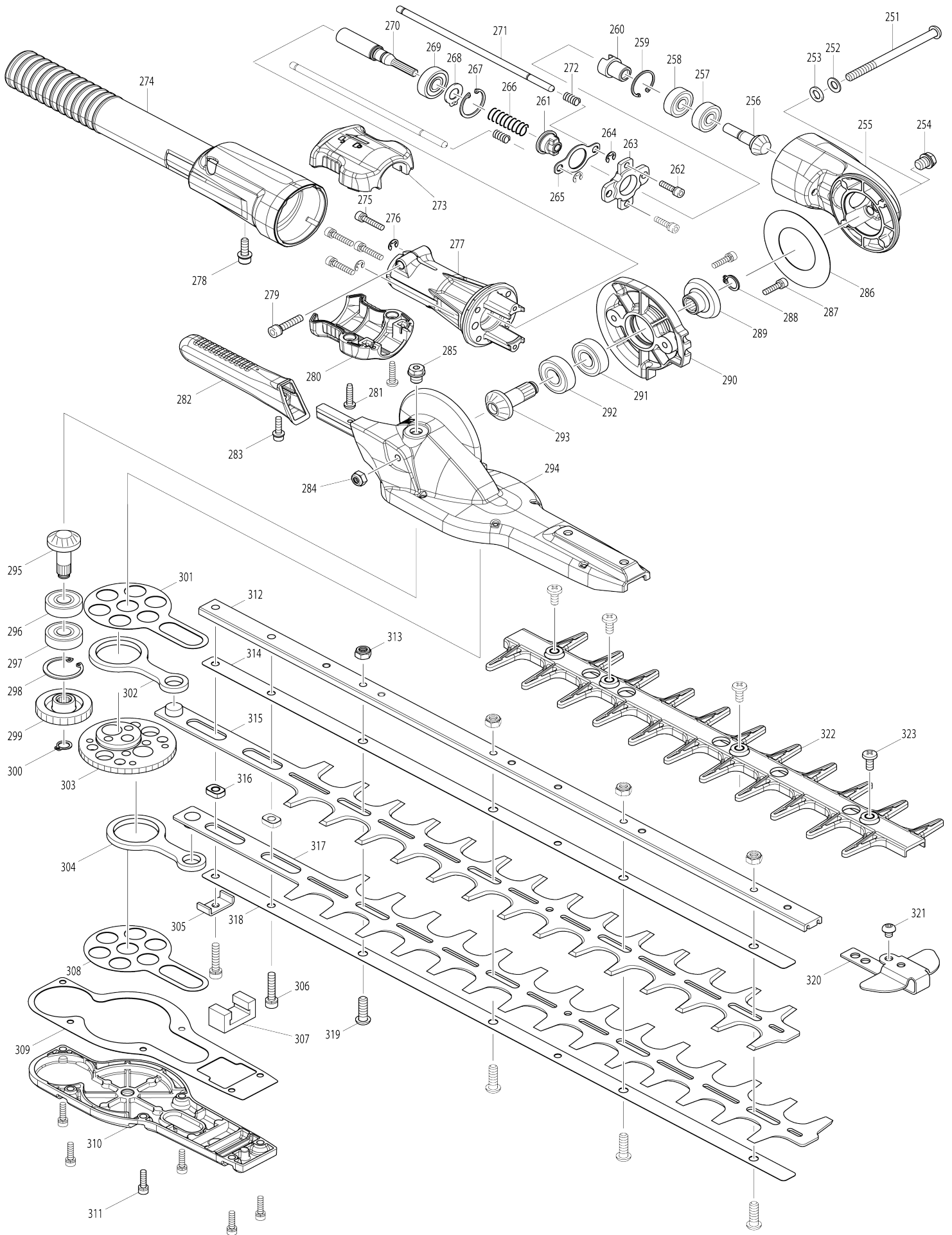

Model No.EN4951SH PETROL POLE HEDGE TRIMMER

Item No.	Parts No.	Description	Interchangeability	Q'ty	New/Old	Note1	Note2
001	123358-1	TRIMMER HEAD ASSEMBLY A		1	*		
D10		INC. 251-323					
001-1	123491-9	TRIMMER HEAD ASSEMBLY A	<	1	*		
D10		INC. 251-323					
001-2	135693-5	TRIMMER HEAD ASSEMBLY A	O	1	*		
D10		INC. 251-323					
001-3	135776-1	TRIMMER HEAD ASSY'S A	<	1			
D10		INC. 251-323					
002	454270-7	BAND		2			
003	326530-6	SHAFT		1			
004	195143-2	HANGER SET		1			
D10		INC. 5					
005	911233-1	PAN HEAD SCREW M5X20		1			
006	143201-8	PIPE COMPLETE A		1			
D10		INC. 219					
007	273531-4	GRIP		1			
008	893670-0	MAKITA LOGO LABEL		1			
009	801D19-4	SERIAL NO. LABEL		1			
010	911148-2	PAN HEAD SCREW M4X25		2			
033	816567-6	SERIAL NO. LABEL		1			
034	819430-2	CAUTION TAG		1			
036	806G66-8	EN4951SH MODEL NO. LABEL		1			
038	126488-7	CONTROL LEVER ASSEMBLY		1			
D10		INC. 39-55					
039	266130-9	TAPPING SCREW BIND PT 3X16		1			
040	451595-0	SWITCH COVER		1			
041	451594-2	SWITCH LEVER		1			
042	232251-9	LEAF SPRING		1			
043	188832-6	LEVER CASE SET		1			
D10		INC. 55					
044	346248-3	CLAMP 24		2			
045	922218-2	H.S.H.BOLT M5X14 WITH WR		2			
046	451593-4	LOCK LEVER		1			
047	233541-3	TORSION SPRING 7		1			
048	168571-4	CONTROL CABLE		1			
049	233540-5	TORSION SPRING 11		1			
050	455313-8	THROTTLE LEVER		1			
051	638714-7	LEAD UNIT		1			
052	638713-9	LEAD UNIT		1			
053	452071-7	CORRUGATE TUBE		1			
054	266326-2	TAPPING SCREW 4X18		4			
055	188832-6	LEVER CASE SET		1			
D10		INC. 43					
060	126202-1	CLEANER COVER ASSEMBLY		1	*		
D10		INC. 61					
060-1	123499-3	CLEANER COVER ASSEMBLY	S	1			
D10		INC. 61					

061	265791-2	THUMB SCREW M4		1		
062	443171-4	AIR CLEANER ELEMENT		1	*	
062-1	443171-4	AIR CLEANER ELEMENT	O	1		
063	443169-1	AIR CLEANER ELEMENT		1		
064	266871-7	H.S.BUTTON HEAD BOLT M5X60		2		
065	126198-6	CLEANER PLATE ASSEMBLY		1	*	
D10		INC. 66-68,223,224,231-234				
065-1	123501-2	CLEANER PLATE ASSEMBLY	S	1		
D10		INC. 66-68,223,224,231-234				
066	162346-3	SEPARATOR PLATE		1		
067	213540-1	O RING 15		1		
068	424316-3	CHECK VALVE		2		
069	422099-9	PIPE		1		
070	325665-0	JOINT PIPE		1		
071	442153-3	CARBURETOR GASKET		1		
072	266787-6	H.S.H.BOLT M5X18 WITH WR		2		
073	451825-9	CLAMP		1		
074	451729-5	INSULATOR		1		
075	213547-7	O-RING 12		1		
076	422109-2	BREATHER PIPE		1		
077	345918-1	HOSE CLAMP		1		
078	318745-9	ROCKER COVER OUTER		1		
079	922222-1	HEX. SOCKET HEAD BOLT M5X16		4		
080	453860-3	ROCKER COVER INNER		1		
081	162304-9	ROCKER COVER GASKET		1		
082	424302-4	PLUG CAP		1		
083	324891-8	PLUG CAP SPRING		1		
084	168534-0	SPARK PLUG		1		
085	125554-7	ROCKER ARM ASSEMBLY		2		
086	256200-2	PIN 5		1		
087	256865-0	ROD 2.5		2		
088	325668-4	SPRING RETAINER		2		
089	451735-0	CLUTCH CASE		1		
090	922228-9	H.S.H.BOLT M5X18 WITH WR		3		
091	450569-8	SPACER		1		
092	961052-5	RETAINING RING (EXT) S-12		1		
093	210111-5	BALL BEARING 6201LLU		1		
094	962151-6	RETAINING RING R-32		1		
095	168809-7	CLUTCH DRUM COMPLETE		1	*	
095-1	161588-6	CLUTCH DRUM COMPLETE	<	1		
096	266864-4	SHOULDER HEX. BOLT M6X25		2		
097	267817-6	WASHER 8		2		
098	126135-0	CLUTCH ASSEMBLY		1		
D10		INC. 99,100				
099	161332-1	CLUTCH SHOE		2		
100	231881-3	TENSION SPRING 7		1		
101	267812-6	WASHER 6		2		
102	264039-9	CONED DISK SPRING HEXNUT M 8-13		1		
103	318569-3	FLYWHEEL		1		
104	444021-6	TUBE		1		
105	266602-4	HEX. SOCKET HEAD BOLT M4X20		2		

106	452049-0	SPACER		2		
107	168559-4	IGNITION COIL		1		
108	268238-5	PIN 5		1		
109	125552-1	CAM GEAR ASSEMBLY		1		
110	313169-4	CAM LIFTER		2		
112	268239-3	PIN 4		1		
113	162274-2	CAM GEAR COVER GASKET		1		
114	318443-5	CAM GEAR COVER		1		
115	922222-1	HEX. SOCKET HEAD BOLT M5X16		3		
116	135478-9	CYLINDER BLOCK ASSEMBLY		1		
D10		INC. 70,117,118,137				
117	922222-1	HEX. SOCKET HEAD BOLT M5X16		6		
118	424201-0	CHECK VALVE		2		
119	346331-6	MUFFLER GASKET		1		
120	168554-4	EXHAUST MUFFLER		1		
121	266440-4	HEX SOCKET HEAD BOLT M5X40		2		
122	168483-1	PULLEY		1		
123	451731-8	MUFFLER PLATE		1		
124	922218-2	H.S.H.BOLT M5X14 WITH WR		1		
125	638707-4	LEAD UNIT		1		
126	638708-2	LEAD UNIT		1		
128	922218-2	H.S.H.BOLT M5X14 WITH WR		1		
129	453266-5	CYLINDER COVER		1		
130	922218-2	H.S.H.BOLT M5X14 WITH WR		1		
131	424082-2	BUFFER RUBBER		1		
132	922211-6	H.S.H.BOLT M5X12 WITH W		1		
133	922226-3	HEX. SOCKET HEAD BOLT M5X18		2		
134	318249-1	PIPE HOLDER		1		
135	318250-6	PIPE HOLDER		1		
136	424083-0	BUFFER RUBBER		1		
137	424200-2	SPACER		2		
138	234108-0	COMPRESSION SPRING 9		2		
140	326366-3	EXHAUST VALVE		1		
143	326367-1	INTAKE VALVE		1		
144	195145-8	PISTON RING SET		1		
147	318441-9	PISTON		1		
148	254040-2	WOODRUFF KEY 3		1		
149	126359-8	CRANK SHAFT ASSEMBLY		1	*	
D10		INC. 150-152				
149-1	123774-7	CRANK SHAFT ASSEMBLY	<	1		
D10		INC. 150-152				
150	213148-1	OIL SEAL 10		1	*	
150-1	213769-9	OIL SEAL 10	<	1		
151	267400-9	FLAT WASHER 23		1		
152	213147-3	OIL SEAL 12		1	*	
152-1	213089-1	OIL SEAL 12	<	1		
153	257781-9	PISTON PIN		1		
154	233976-8	CLIP		2		
155	162345-5	OIL CASE GASKET		1		
156	346083-9	LEAD VALVE		1		
157	318910-0	RETAINER PLATE		1		
158	922112-8	HEX. SOCKET HEAD BOLT M4X10		1		

159	318588-9	OIL CASE		1		
160	922222-1	HEX. SOCKET HEAD BOLT M5X16		4		
161	424344-8	DAMPER		1		
162	346305-7	GASKET		1		
163	266611-3	HEX BOLT M6X8		1		
164	213548-5	O-RING 20		1		
165	325665-0	JOINT PIPE		1		
166	282020-8	HOSE CLAMP		1	*	
166-1	282020-8	HOSE CLAMP	O	1		
167	325666-8	OIL WEIGHT		1	*	
167-1	325666-8	OIL WEIGHT	O	1		
168	424301-6	OIL TUBE		1	*	
168-1	125805-8	OIL TUBE ASSEMBLY	S	1		
C10	424301-6	OIL TUBE		1		
D10		INC. 166,167				
169	452047-4	OIL CAP		1		
170	424343-0	GASKET		1		
171	452048-2	OIL PIPE		1		
172	922218-2	H.S.H.BOLT M5X14 WITH WR		2		
173	125728-0	FUEL TANK CAP ASSEMBLY		1	*	
173-1	127112-5	FUEL TANK CAP ASSEMBLY	O	1		
175	168755-4	TUBE COMPLETE		1		
176	282020-8	HOSE CLAMP		1		
177	163518-3	GASOLINE FILTER		1		
178	451736-8	FUEL TANK		1		
179	424080-6	BUFFER RUBBER		2		
180	424081-4	BUFFER RUBBER		1		
181	451737-6	TANK GUARD		1		
182	922218-2	H.S.H.BOLT M5X14 WITH WR		4		
183	125752-3	RECOIL STARTER ASSEMBLY		1		
D10		INC. 184,185,187-193				
184	424319-7	STARTER KNOB		1		
185	424359-5	DAMPER		1		
187	266585-8	TAPPING SCREW 5X12		1		
188	325923-4	SWING ARM		1		
189	451938-6	COLLAR		1		
190	451937-8	REEL		1		
191	232258-5	SPIRAL SPRING		1		
192	444023-2	STARTER ROPE		1		
193	451733-4	STARTER CASE		1		
194	922223-9	H.S.H.BOLT M5X16 WITH WR		4		
196	816565-0	MAKITA LOGO LABEL		1		
197	168762-7	CARBURETOR		1		
D10		INC. 198-207,209-214				
198	325922-6	SWIVEL		1		
199	413140-9	WASHER		1		
200	266581-6	PAN HEAD SCREW M3X8 WITH W		2	*	
200-1	WJ00096364	SCREW M3X8 WITH WASHER	O	2		
201	257964-1	STOP RING E-3		1		
202	213538-8	O RING 2		1		
203	325985-2	JET		1		

204	234183-6	CONICAL COMPRESSION SPRING 5-9		1		
205	442155-9	PUMP GASKET		1		
206	168575-6	PUMP DIAPHRAGM		1	*	
206-1	WJ00009599	PUMP DIAPHRAGM	O	1		
207	141737-1	PUMP BODY		1		
D10		INC. 208				
208	352021-1	INLET SCREEN		1		
209	442154-1	METERING DIAPHRAGM GASKET		1		
210	168620-7	METERING DIAPHRAGM		1		
211	140438-8	AIR PURGE BODY		1		
212	424314-7	PRIMER PUMP		1		
213	346270-0	PRIMER PUMP COVER		1		
214	266582-4	TAPPING SCREW 3X24		4		
215	810455-9	CAUTION PLATE		1		
216	800F73-7	INDICATION LABEL		1		
217	941151-9	FLAT WASHER 6		1		
218	443170-6	FELT		1		
219	806G68-4	CAUTION LABEL		1		
223	266427-6	TAPPING SCREW 4X12		1		
224	452219-1	CHOKE PLATE		1		
231	452220-6	CHOKE LEVER		1		
232	266007-8	TAPPING SCREW BIND PT 3X10		1		
233	352020-3	SEPARATOR MESH		1		
234	453865-3	SEPARATOR CASE		1		
235	453862-9	OIL CASE PLATE		1		
236	346732-8	PLATE		1		
237	266927-6	H.L. SOCKET HEAD BOLT M4X20		1		
238	442199-9	GASKET		1		
239	931102-0	HEX. NUT M4		1		
240	346730-2	HOLDER		1		
251	266817-3	H.S. BUTTON HEAD BOLT M6X85		1		
252	232279-7	CONED DISC SPRING 6		1		
253	941151-9	FLAT WASHER 6		1		
254	266818-1	HEX. SOCKET HEX. BOLT M8X8		1		
255	318969-7	JOINT		1		
256	227604-5	SPIRAL BEVEL GEAR 9		1	*	
256-1	227A84-1	SPIRAL BEVEL GEAR 9	S	1		
257	211032-4	BALL BEARING 608ZZ		1	*	
257-1	210191-1	BALL BEARING 608ZZ	O	1		
258	211032-4	BALL BEARING 608ZZ		1	*	
258-1	210191-1	BALL BEARING 608ZZ	O	1		
259	962102-9	RETAINING RING R-22		1		
260	310534-8	CAM A		1		
261	310535-6	CAM B		1		
262	922126-7	HEX. SOCKET HEAD BOLT M4X16		2		
263	313254-3	HOLDER PLATE		1		
264	961011-9	STOP RING E-4		2		
265	346657-6	SLIDE PLATE		1		
266	231297-2	COMPRESSION SPRING 9		1		
267	962103-7	RETAINING RING R-24		1		
268	961005-4	RETAINING RING S-9		1		

269	210049-4	BALL BEARING 609ZZ		1	*		
269-1	210217-9	BALL BEARING 609ZZ	O	1			
270	142000-5	SPINDLE COMPLETE		1			
271	326256-0	ROD 5		2	*		
271-1	326812-6	ROD 5	<	2			
272	233117-6	COMPRESSION SPRING 6		2			
273	187575-7	SLIDE LEVER SET		1			
D10		INC. 280					
274	454249-8	COVER		1			
275	265493-0	HEX. SOCKET HEAD BOLT M4X20		4			
276	961011-9	STOP RING E-4		2			
277	318970-2	PIPE HOLDER		1			
278	922223-9	H.S.H.BOLT M5X16 WITH WR		1			
279	922241-7	HEX. SOCKET HEAD BOLT M5X25		1			
280	187575-7	SLIDE LEVER SET		1			
D10		INC. 273					
281	265995-6	TAPPING SCREW 4X18		2			
282	454248-0	GRIP		1	*		
282-1	456369-4	GRIP	S	1			
283	922128-3	HEX. SOCKET HEAD BOLT M4X16		1	*		
283-1	911516-9	PAN HEAD SCREW M4X12	S	2			
284	252190-7	HEX.LOCK NUT M6-10		1			
285	266818-1	HEX. SOCKET HEX. BOLT M8X8		1			
286	267467-7	FLAT WASHER 36		1			
287	922126-7	HEX. SOCKET HEAD BOLT M4X16		2			
288	961006-2	RETAINING RING S-10		1			
289	227605-3	SPIRAL BEVEL GEAR 22		1	*		
289-1	227A85-9	SPIRAL BEVEL GEAR 22	S	1			
290	310533-0	ANGULAR PLATE		1			
291	211148-5	BALL BEARING 6001ZZ		1	*		
291-1	210263-2	BALL BEARING 6001ZZ	O	1			
292	211148-5	BALL BEARING 6001ZZ		1	*		
292-1	210263-2	BALL BEARING 6001ZZ	O	1			
293	227606-1	SPIRAL BEVEL GEAR 11		1			
294	142018-6	GEAR HOUSING COMPLETE		1	*		
294-1	143500-8	GEAR HOUSING COMPLETE	S	1			
295	227607-9	SPIRAL BEVEL GEAR 12		1			
296	211062-5	BALL BEARING 6000ZZ		1			
297	211062-5	BALL BEARING 6000ZZ		1			
298	962105-3	RETAINING RING R-26		1			
299	227317-8	SPUR GEAR 24		1			
300	961004-6	RETAINING RING (EXT) S-8		1			
301	346658-4	PLATE		1			
302	346251-4	CONNECTING ROD		1			
303	227248-1	SPUR GEAR 43		1			
304	346251-4	CONNECTING ROD		1			
305	346256-4	HOLDER		1			
306	922241-7	HEX. SOCKET HEAD BOLT M5X25		2			
307	443159-4	SEAL		1			
308	346658-4	PLATE		1			
309	423458-0	GASKET		1			
310	318968-9	UNDER COVER		1			

311	922126-7	HEX. SOCKET HEAD BOLT M4X16		6		
312	332058-4	GUIDE BAR		1		
313	264089-4	HEX. LOCK NUT M6-10		4		
314	346665-7	PLATE		1		
315	725187-4	SHEAR BLADE		1		
316	313211-1	SLEEVE 5		2		
317	725187-4	SHEAR BLADE		1		
318	346665-7	PLATE		1		
319	266824-6	H.S. BUTTON HEAD BOLT M6X20		4		
320	346629-1	END COVER		1		
321	266075-1	HEX. SOCKET HEAD BOLT M5X6		1		
322	454672-7	BLADE GUARD		1		
323	915211-3	BINDING HEAD SCREW M5X12		4		
324	135668-4	SHORT BLOCK ASS'Y 25.4CC		1		
D10		INC. 85-88,108-110,112-116,138				
D20		140,143,144,147.149,153,154				
A01	195500-4	OIL SET		1	*	
A01-1	197007-6	OIL SET	O	1	*	
A01-2	191A18-9	OIL SET	O	1	*	
A01-3	197007-6	OIL SET	O	1		
A02	454279-9	BLADE COVER		1		
A03	782233-6	BOX DRIVER 10-16		1		
A04	783223-2	HEX. WRENCH 4		1		
A05	831304-7	ACCESSORY BAG		1		
A06	125516-5	BAND ASSEMBLY		1		

Please state Parts No. when your order.

Print Date 23/10/2023