

Model No.EY2650H TELESCOPIC PETROL POLE SAW

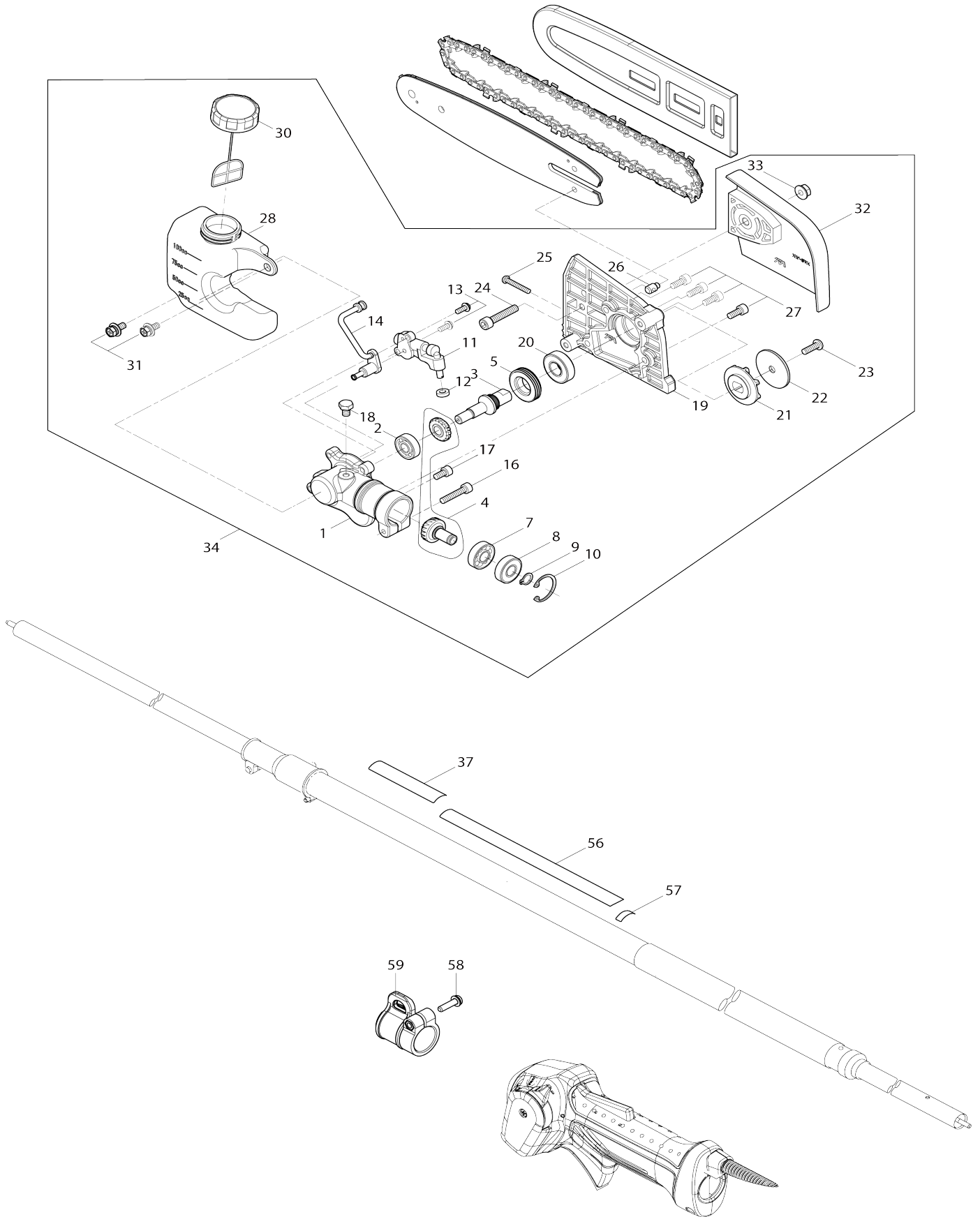

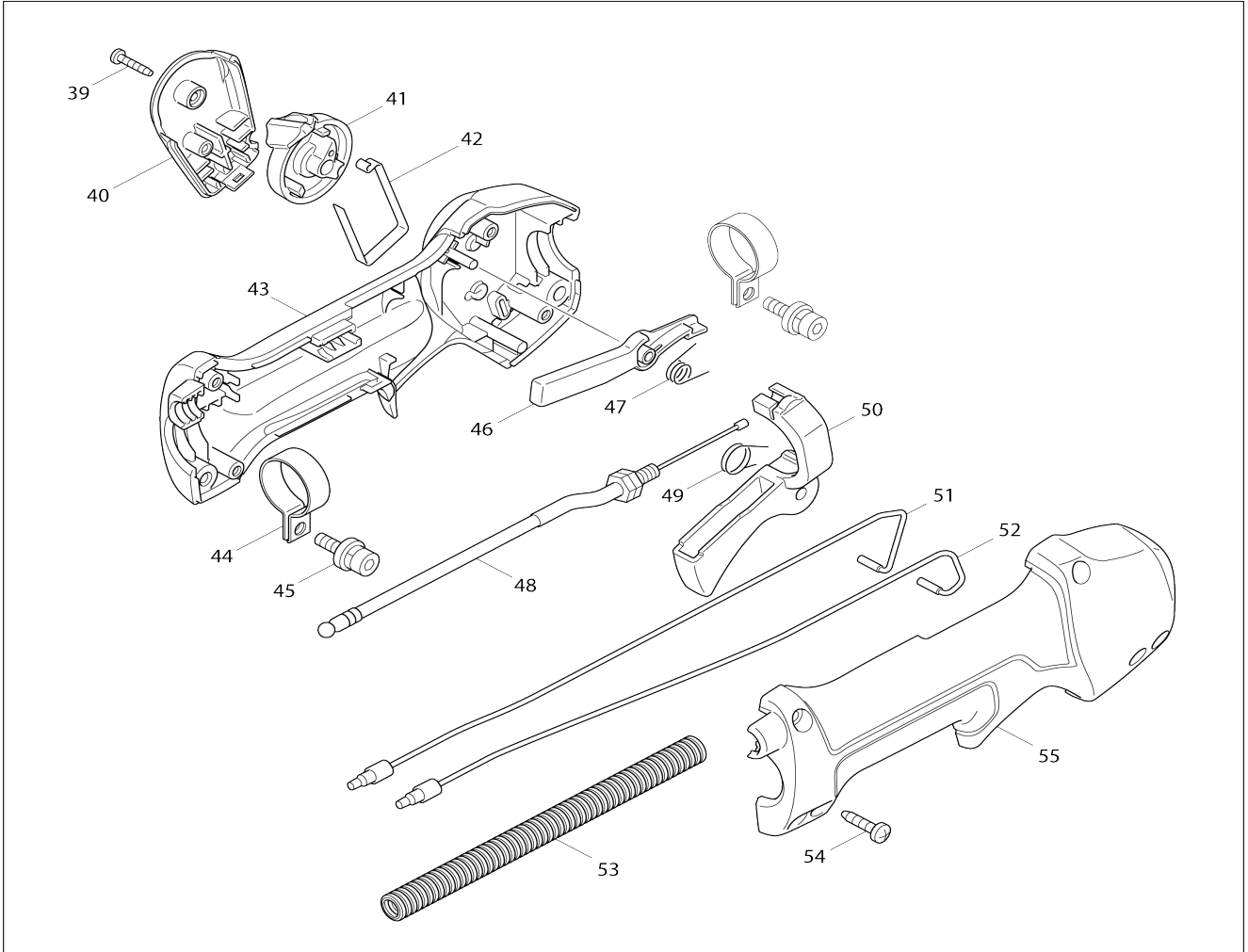

Model No.EY2650H TELESCOPIC PETROL POLE SAW

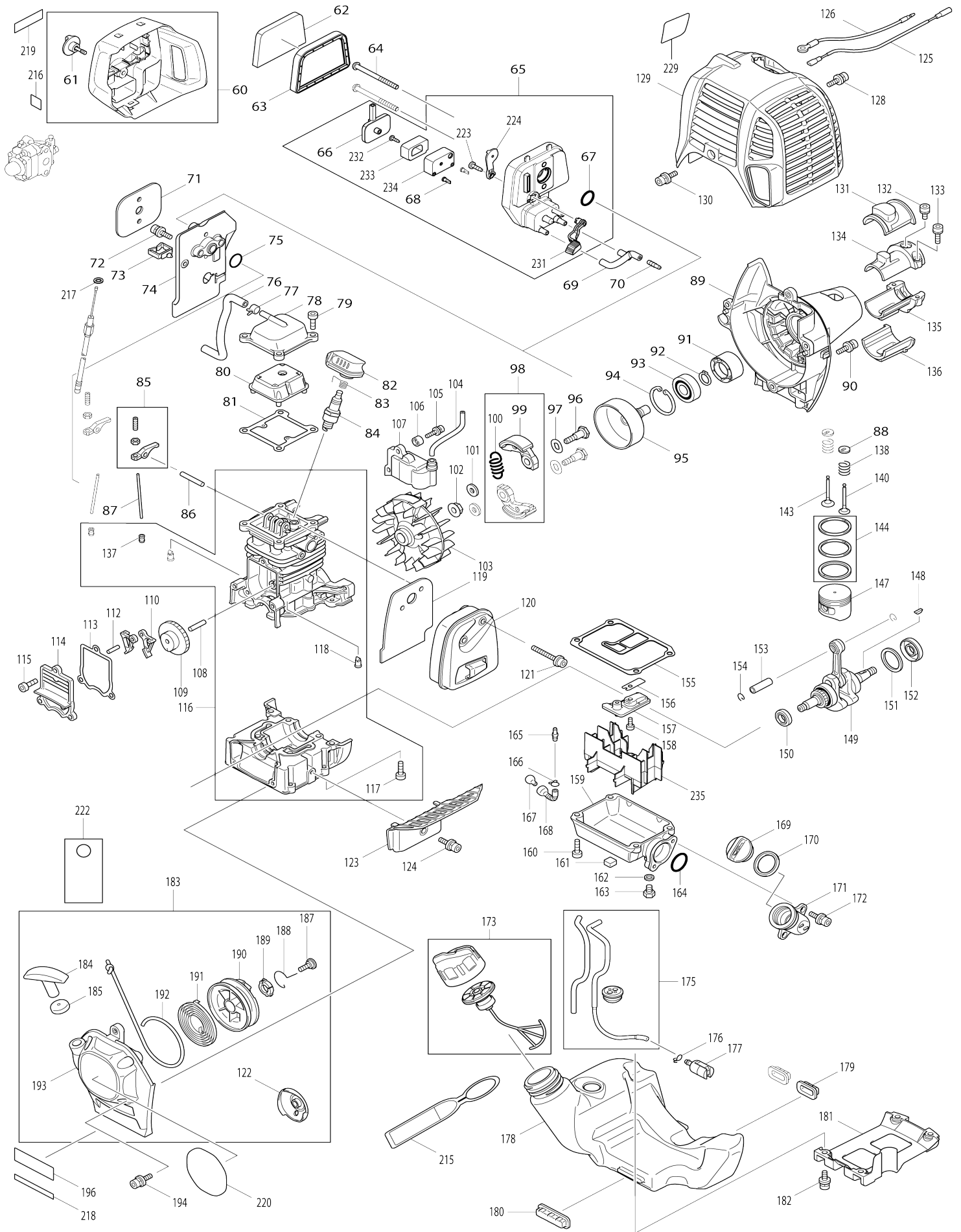

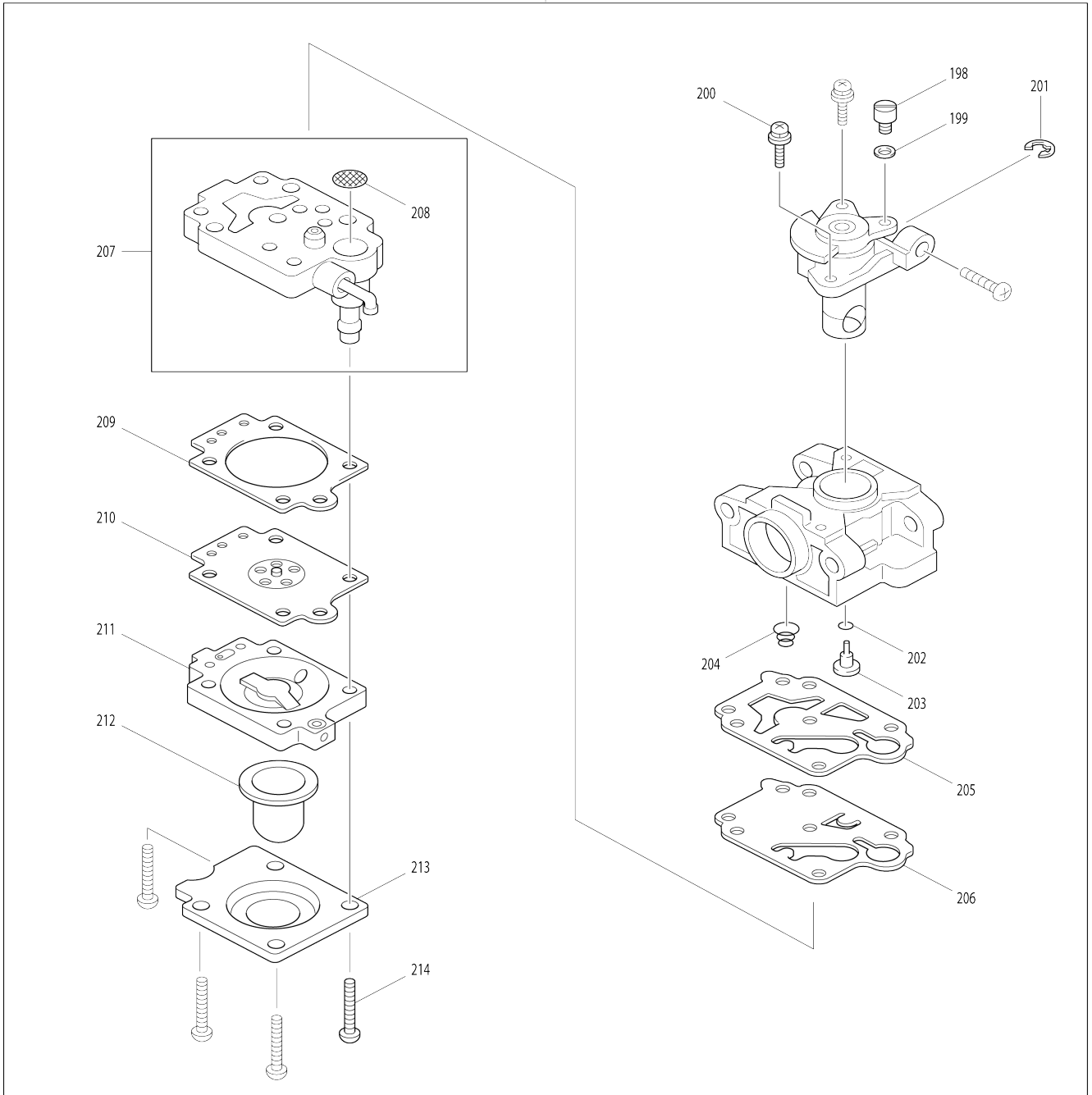

Model No.EY2650H TELESCOPIC PETROL POLE SAW

309

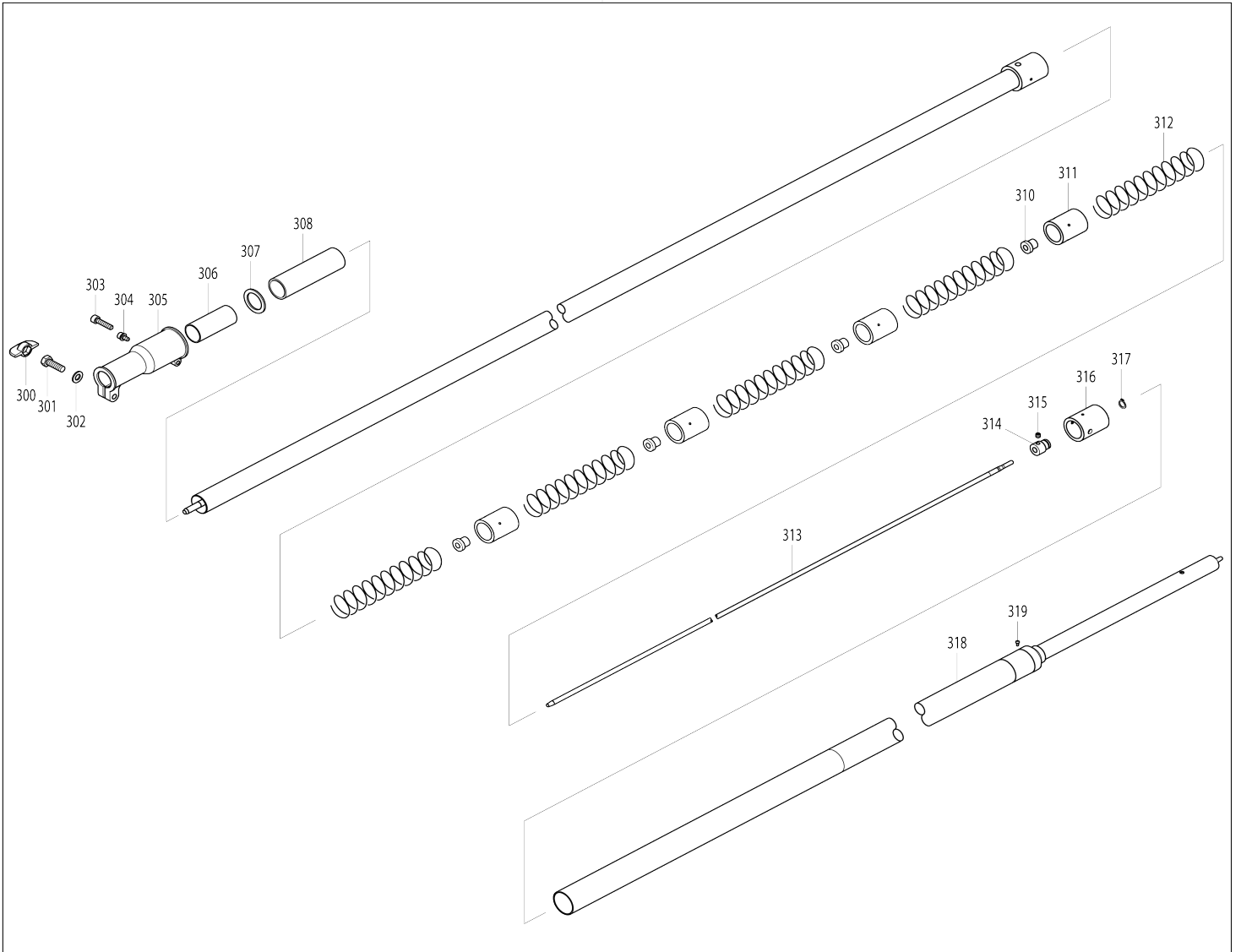

Model No.EY2650H TELESCOPIC PETROL POLE SAW

Item No.	Parts No.	Description	Interchangability	Q'ty	New/Old	Note1	Note2
001-1	XTM0000029	GEAR CASE A		1			
002	XTM0000002	BALL BEARING 608		1			
003-1	XTM0000024	GEAR SHAFT		1	*		
003-2	XTM0000030	GEAR SHAFT	S	1			
004-1	XTM0000028	BEVEL GEAR SET		1			
005	XTM0000005	WORM WHEEL		1			
007	XTM0000006	BALL BEARING 609		1			
008	XTM0000007	BALL BEARING 609Z		1			
009	961005-4	RETAINING RING S-9		1			
010	962103-7	RETAINING RING R-24		1			
011-1	XTM0000025	OIL PUMP		1			
012	XTM0000009	SEAL		1			
013	911111-5	PAN HEAD SCREW M4X10 WITH W		2			
014	XTM0000010	OIL PIPE ASS'Y		1			
016	922242-5	HEX. SOCKET HEAD BOLT M5X25		1			
017	922207-7	HEX. SOCKET HEAD BOLT M5X10		1			
018	XTM0000011	HB BOLT 6X8		1			
019-2	XTM0000027	GEAR CASE B		1			
020	XTM0000013	BALL BEARING 6001DDW		1			
021	XTM0000014	SPROCKET		1			
022	XTM0000015	SPEOCKET WASHER		1	*		
022-1	XTM0000031	SPROCKET WASHER	S	1			
023	XTM0000016	H.S. BOTTON HEAD SCREW M6X15		1	*		
023-1	XTM0000032	E RING	S	1			
024	922352-8	HEX. SOCKET HEAD BOLT M6X30		1			
025	XTM0000017	ADJUSTER SCREW M4X30		1	*		
025-1	XTM0000017	ADJUSTER SCREW M4X30	O	1			
026	XTM0000018	ADJUSTER		1			
027	922212-4	HEX. SOCKET HEAD BOLT M5X12		4			
028	XTM0000019	OIL TANK ASS'Y		1			
030	XTM0000020	TANK CAP ASS'Y		1			
031	XTM0000021	H.S.H.BOLT M5X12SW		2			
032	XTM0000022	CHAIN COVER		1			
033	XTM0000023	FLANGE NUT M6		1			
034-2	123366-2	POLE SAW HEAD ASSEMBLY		1	*		
D10		INC. 1-5,7-14,16-28,30-33					
034-3	127300-4	POLE SAW HEAD ASSEMBLY	<	1			
D10		INC. 1-5,7-14,16-28,30-33					
037-1	808D12-9	MAKITA LOGO LABEL		1			
038	126488-7	CONTROL LEVER ASSEMBLY		1			
D10		INC. 39-55					
039	266130-9	TAPPING SCREW BIND PT 3X16		1			
040	451595-0	SWITCH COVER		1			
041	451594-2	SWITCH LEVER		1			
042	232251-9	LEAF SPRING		1			
043	188832-6	LEVER CASE SET		1			

D10		INC. 55				
044	346248-3	CLAMP 24		2		
045	922218-2	H.S.H.BOLT M5X14 WITH WR		2		
046	451593-4	LOCK LEVER		1		
047	233541-3	TORSION SPRING 7		1		
048	168571-4	CONTROL CABLE		1		
049	233540-5	TORSION SPRING 11		1		
050	455313-8	THROTTLE LEVER		1		
051	638714-7	LEAD UNIT		1		
052	638713-9	LEAD UNIT		1		
053	452071-7	CORRUGATE TUBE		1		
054	266326-2	TAPPING SCREW 4X18		4		
055	188832-6	LEVER CASE SET		1		
D10		INC. 43				
056	803K81-7	CAUTION LABEL		1		
057	801D19-4	SERIAL NO. LABEL		1		
058	911233-1	PAN HEAD SCREW M5X20		1		
059	168478-4	HANGER		1		
060-1	123499-3	CLEANER COVER ASSEMBLY		1		
D10		INC. 61				
061	265791-2	THUMB SCREW M4		1		
062	443171-4	AIR CLEANER ELEMENT		1	*	
062-1	443171-4	AIR CLEANER ELEMENT	O	1		
063	443169-1	AIR CLEANER ELEMENT		1		
064	266618-9	H.S.BUTTON HEAD BOLT M5X60		2		
065-1	123501-2	CLEANER PLATE ASSEMBLY		1		
D10		INC. 66-68,223,224,231-234				
066	162346-3	SEPARATOR PLATE		1		
067	213540-1	O RING 15		1		
068	424316-3	CHECK VALVE		2		
069	422099-9	PIPE		1		
070	325665-0	JOINT PIPE		1		
071	442153-3	CARBURETOR GASKET		1		
072	266787-6	H.S.H.BOLT M5X18 WITH WR		2		
073	451825-9	CLAMP		1		
074	451729-5	INSULATOR		1		
075	213547-7	O-RING 12		1		
076	422109-2	BREATHER PIPE		1		
077	345918-1	HOSE CLAMP		1		
078	318745-9	ROCKER COVER OUTER		1		
079	922222-1	HEX. SOCKET HEAD BOLT M5X16		4		
080	453860-3	ROCKER COVER INNER		1		
081	162304-9	ROCKER COVER GASKET		1		
082	424302-4	PLUG CAP		1		
083	324891-8	PLUG CAP SPRING		1		
084	168534-0	SPARK PLUG		1		
085	125554-7	ROCKER ARM ASSEMBLY		2		
086	256200-2	PIN 5		1		
087	256865-0	ROD 2.5		2		
088	325668-4	SPRING RETAINER		2		
089	451735-0	CLUTCH CASE		1		
090	922228-9	H.S.H.BOLT M5X18 WITH WR		3		

091	450569-8	SPACER		1		
092	961052-5	RETAINING RING (EXT) S-12		1		
093	210111-5	BALL BEARING 6201LLU		1		
094	962151-6	RETAINING RING R-32		1		
095	165747-4	CLUTCH DRUM COMPLETE		1		
096	266864-4	SHOULDER HEX. BOLT M6X25		2		
097	267817-6	WASHER 8		2		
098	126135-0	CLUTCH ASSEMBLY		1		
D10		INC. 99,100				
099-1	161332-1	CLUTCH SHOE		2		
100	231881-3	TENSION SPRING 7		1		
101	267812-6	WASHER 6		2		
102	264039-9	CONED DISK SPRING HEXNUT M 8-13		1		
103	318569-3	FLYWHEEL		1		
104	444021-6	TUBE		1		
105	266602-4	HEX. SOCKET HEAD BOLT M4X20		2		
106	452049-0	SPACER		2		
107	168559-4	IGNITION COIL		1		
108	268238-5	PIN 5		1		
109	125552-1	CAM GEAR ASSEMBLY		1		
110	313169-4	CAM LIFTER		2		
112	268239-3	PIN 4		1		
113	162274-2	CAM GEAR COVER GASKET		1		
114	318443-5	CAM GEAR COVER		1		
115	922222-1	HEX. SOCKET HEAD BOLT M5X16		3		
116	135478-9	CYLINDER BLOCK ASSEMBLY		1		
D10		INC. 117,118,137				
117	922222-1	HEX. SOCKET HEAD BOLT M5X16		6		
118	424201-0	CHECK VALVE		2		
119	346331-6	MUFFLER GASKET		1		
120	168554-4	EXHAUST MUFFLER		1		
121	266440-4	HEX SOCKET HEAD BOLT M5X40		2		
122	168483-1	PULLEY		1		
123	451731-8	MUFFLER PLATE		1		
124	922218-2	H.S.H.BOLT M5X14 WITH WR		1		
125	638707-4	LEAD UNIT		1		
126	638708-2	LEAD UNIT		1		
128	922218-2	H.S.H.BOLT M5X14 WITH WR		1		
129	453266-5	CYLINDER COVER		1		
130	922218-2	H.S.H.BOLT M5X14 WITH WR		1		
131	424082-2	BUFFER RUBBER		1		
132	922211-6	H.S.H.BOLT M5X12 WITH W		1		
133	922226-3	HEX. SOCKET HEAD BOLT M5X18		2		
134	318249-1	PIPE HOLDER		1		
135	318250-6	PIPE HOLDER		1		
136	424083-0	BUFFER RUBBER		1		
137	424200-2	SPACER		2		
138	234108-0	COMPRESSION SPRING 9		2		
140-1	326366-3	EXHAUST VALVE		1		
143-1	326367-1	INTAKE VALVE		1		
144	195145-8	PISTON RING SET		1		

147	318441-9	PISTON		1		
148	254040-2	WOODRUFF KEY 3		1		
149-1	123774-7	CRANK SHAFT ASSEMBLY		1		
D10		INC. 150-152				
150-1	213769-9	OIL SEAL 10		1		
151	267400-9	FLAT WASHER 23		1		
152-1	213089-1	OIL SEAL 12		1		
153	257781-9	PISTON PIN		1		
154	233976-8	CLIP		2		
155	162345-5	OIL CASE GASKET		1		
156	346083-9	LEAD VALVE		1		
157	318910-0	RETAINER PLATE		1		
158	922112-8	HEX. SOCKET HEAD BOLT M4X10		1		
159	318588-9	OIL CASE		1		
160	922222-1	HEX. SOCKET HEAD BOLT M5X16		4		
161	424344-8	DAMPER		1		
162	346305-7	GASKET		1		
163	266611-3	HEX BOLT M6X8		1		
164	213548-5	O-RING 20		1		
165	325665-0	JOINT PIPE		1		
166-1	282020-8	HOSE CLAMP		1		
167-1	325666-8	OIL WEIGHT		1		
168-1	125805-8	OIL TUBE ASSEMBLY		1		
C10	424301-6	OIL TUBE		1		
D10		INC. 166,167				
169	452047-4	OIL CAP		1		
170	424343-0	GASKET		1		
171	452048-2	OIL PIPE		1		
172	922218-2	H.S.H.BOLT M5X14 WITH WR		2		
173	125728-0	FUEL TANK CAP ASSEMBLY		1	*	
173-1	127112-5	FUEL TANK CAP ASSEMBLY	O	1		
175	168755-4	TUBE COMPLETE		1		
176	282020-8	HOSE CLAMP		1		
177	163518-3	GASOLINE FILTER		1		
178	451736-8	FUEL TANK		1		
179	424080-6	BUFFER RUBBER		2		
180	424081-4	BUFFER RUBBER		1		
181	451737-6	TANK GUARD		1		
182	922218-2	H.S.H.BOLT M5X14 WITH WR		4		
183	195308-6	RECOIL STARTER SET		1		
D10		INC. 122,184,185,187-193				
184	424319-7	STARTER KNOB		1		
185	424359-5	DAMPER		1		
187	266585-8	TAPPING SCREW 5X12		1		
188	325923-4	SWING ARM		1		
189	451938-6	COLLAR		1		
190	451937-8	REEL		1		
191	232258-5	SPIRAL SPRING		1		
192	444023-2	STARTER ROPE		1		
193	451733-4	STARTER CASE		1		
194	922223-9	H.S.H.BOLT M5X16 WITH WR		4		

196	816565-0	MAKITA LOGO LABEL		1		
197	168762-7	CARBURETOR		1		
D10		INC. 198-207,209-214				
198	325922-6	SWIVEL		1		
199	413140-9	WASHER		1		
200-1	WJ00096364	SCREW M3X8 WITH WASHER		2		
201	257964-1	STOP RING E-3		1		
202	213538-8	O RING 2		1		
203	325985-2	JET		1		
204	234183-6	CONICAL COMPRESSION SPRING 5-9		1		
205	442155-9	PUMP GASKET		1		
206-1	WJ00009599	PUMP DIAPHRAGM		1		
207	141737-1	PUMP BODY		1		
D10		INC. 208				
208	352021-1	INLET SCREEN		1		
209	442154-1	METERING DIAPHRAGM GASKET		1		
210	168620-7	METERING DIAPHRAGM		1		
211	140438-8	AIR PURGE BODY		1		
212	424314-7	PRIMER PUMP		1		
213	346270-0	PRIMER PUMP COVER		1		
214	266582-4	TAPPING SCREW 3X24		4		
215	810455-9	CAUTION PLATE		1		
216	800F73-7	INDICATION LABEL		1		
217	941151-9	FLAT WASHER 6		1		
218	816567-6	SERIAL NO. LABEL		1		
220	803K90-6	EY2650H MODEL NO. LABEL		1		
222	819430-2	CAUTION TAG		1		
223	266427-6	TAPPING SCREW 4X12		1		
224	452219-1	CHOKE PLATE		1		
231	452220-6	CHOKE LEVER		1		
232	266007-8	TAPPING SCREW BIND PT 3X10		1		
233	352020-3	SEPARATOR MESH		1		
234	453865-3	SEPARATOR CASE		1		
235	453862-9	OIL CASE PLATE		1		
236-1	135668-4	SHORT BLOCK ASS'Y 25.4CC		1		
D10		INC. 85-88,108-110,112-118,				
D20		INC. 137,138,140,143,144,147,				
D30		INC. 149-154				
300	TF6116068B	KNOB		1		
301	TF119F0840	HEX.BOLT		1		
302	TF411M0800	FLAT WASHER		1		
303	TF120S0625	HEX.SOCKET HEAD BOLT (M6X25)		1		
304	TF120S0510	HEX.SOCKET HEAD BOLT (M5X10)		1		
305	TF2616001A	SLIDE HOLDER		1		
306	TF6126008A	SLEEVE		1		
307	TF3651008A	SLIDE HOLDER WASHER		1		
308	TF6362070A	CUSHION TUBE		1		
309-1	142607-7	TELESCOPIC PIPE COMPLETE		1		
C10	TF3312328A	MAIN PIPE ASSY		1		

D10		INC. 56,300-319				
310	TF6126009A	DRIVE BUSH		4		
311	TF6126010A	BUSH HOLDER		4		
312	TF5313012A	SPRING		5		
313	TF4117027A	DRIVE SHAFT		1		
314	TF4613005B	SET COLLAR		1		
315	TF290Q0506	HEX.SOCKET HEAD SET SCREW		1		
316	TF6126010A	BUSH HOLDER		1		
317	TF480J1200	SNAP RING (S-12)		1		
318-1	TF3318145B	GUIDE PIPE ASSY		1		
319	TF244F0408	SCREW		1		
320	286284-6	CAP		1		
A01	125516-5	BAND ASSEMBLY		1		
A02	195246-2	SAFETY GOGGLE		1	*	
A03-1	197007-6	OIL SET		1	*	
A03-2	191A18-9	OIL SET	O	1	*	
A03-3	197007-6	OIL SET	O	1		
A04	831304-7	ACCESSORY BAG		1		
A05	782233-6	BOX DRIVER 10-16		1		
A06	783020-6	- DRIVER		1		
A07	783223-2	HEX. WRENCH 4		1		
A08	165695-7	GUIDE BAR 10		1		
A09	452093-7	GUIDE BAR CASE		1		
A10	196142-7	SAW CHAIN SET		1	*	
A10-1	191H20-4	SAW CHAIN 10 SET	O	1		

Please state Parts No. when your order.

Print Date 23/10/2023