

# Model No.GA9081 230MM ANGLE GRINDER

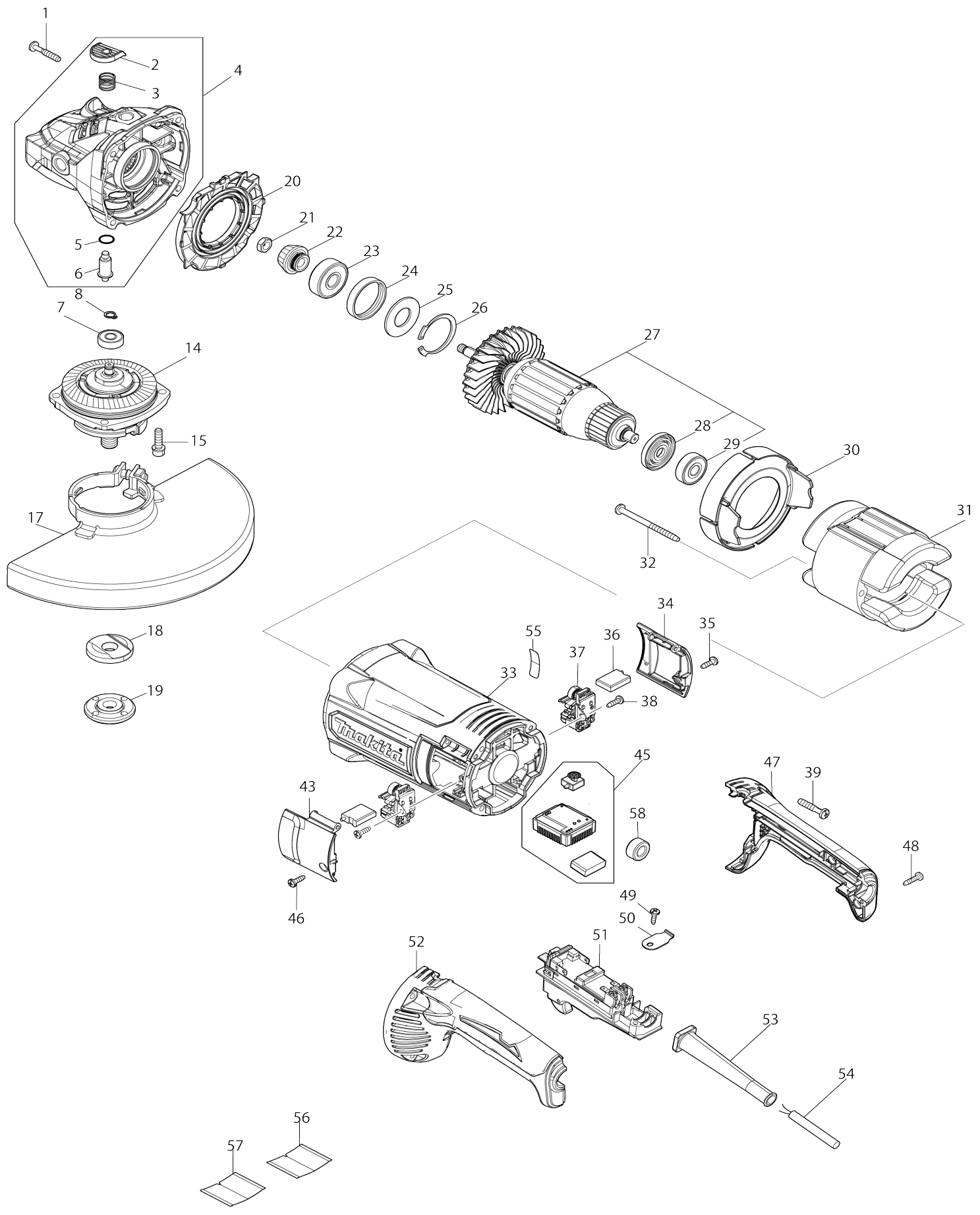

Model No.GA9081 230MM ANGLE GRINDER

Item No.	Parts No.	Description	Interchangability	Q'ty	New/Old	Note1	Note2
001	251489-7	TAPPING SCREW 5X30		4	*		
001-1	922253-0	H.S.H.BOLT M5X30 WITH WR	<	4			
002	413H41-9	PIN CAP		1			
003	233292-8	COMPRESSION SPRING 12		1			
004	136698-8	GEAR HOUSING ASSY		1			
C10	262118-7	FELT RING 18		1			
C20	263002-9	RUBBER PIN 4		1			
D10		INC. 2,3,5,6					
005	213062-1	O RING 9		1			
006	256491-5	SHOULDER PIN 5		1			
007	211032-4	BALL BEARING 608ZZ		1			
008	961004-6	RETAINING RING (EXT) S-8		1			
014	122C64-3	TORQUE LIMITER ASSEMBLY 230		1			
C10	213760-7	O RING 78		1			
C15	252429-8	NUT M15-23		1	*		
C16	252323-4	CIRCULAR NUT M15-23	<	1			
C20	232163-6	CUP SPRING 20		2			
C25	267798-4	LOCK WASHER		1			
C30	227492-0	SPIRAL BEVEL GEAR 53C		1			
C35	265120-9	PAN HEAD SCREW M5X16		3			
C40	285741-1	BEARING RETAINER 50		1			
C45	267167-9	FLAT WASHER 15		1			
C50	211278-2	BALL BEARING 6203DDW		1			
C55	312D39-8	BEARING BOX		1			
C60	141D62-4	SPINDLE COMPLETE		1			
015	265541-5	HEX. SOCKET HEAD BOLT M6X22		4			
017	122891-0	WHEEL COVER 230K ASSEMBLY		1	*		
C10	213017-6	O RING 6		1	*		
C20	265198-2	+PAN HEAD SCREW M8X25		1	*		
017-1	141P32-5	WHEEL COVER 230K COMPLETE	<	1			
C10	213017-6	O RING 6		1			
C20	265198-2	+PAN HEAD SCREW M8X25		1			
C30	8050A1-8	CAUTION LABEL		1			
018	224490-5	INNER FLANGE 14-45		1			
019	224485-8	LOCK NUT 14-45		1			
020	456238-9	DIFFUSER		1			
021	252194-9	HEX. NUT M8		1			
022	227490-4	SPIRAL BEVEL GEAR 12		1			
023	211132-0	BALL BEARING 6301DDW		1			
024	262085-6	RUBBER RING 38		1			
025	267299-2	FLAT WASHER 20		1			
026	962211-4	RETAINING RING R-42		1			
027	511A29-2	ARMATURE ASS'Y 240V		1			
C10	240161-6	FAN 86		1			
D10		INC. 28,29					
028	681630-2	INSULATION WASHER		1			
029	211087-9	BALL BEARING 6200DDW		1			

030	456239-7	BAFFLE PLATE		1		
031	627086-5	FIELD 240V		1		
032	266038-7	TAPPING SCREW 5X70		2		
033	413599-0	MOTOR HOUSING		1		
034	456246-0	BRUSH HOLDER COVER R		1		
035	266385-6	TAPPING SCREW 4X14		1	*	
035-1	265B74-2	TAPPING SCREW 4X14	O	1	*	
035-2	266385-6	TAPPING SCREW 4X14	O	1		
036	191T31-1	CARBON BRUSH SET CB-224		1		
037	643715-2	BRUSH HOLDER		2		
038	266385-6	TAPPING SCREW 4X14		2	*	
038-1	265B74-2	TAPPING SCREW 4X14	O	2	*	
038-2	266385-6	TAPPING SCREW 4X14	O	2		
039	251489-7	TAPPING SCREW 5X30		4		
043	456245-2	BRUSH HOLDER COVER L		1		
045	620E20-4	CONTROLLER		1		
046	266385-6	TAPPING SCREW 4X14		1	*	
046-1	265B74-2	TAPPING SCREW 4X14	O	1	*	
046-2	266385-6	TAPPING SCREW 4X14	O	1		
047	183C62-2	HANDLE SET		1		
D10		INC. 52				
048	266326-2	TAPPING SCREW 4X18		2	*	
048-1	265B67-9	TAPPING SCREW 4X18	O	2	*	
048-2	266326-2	TAPPING SCREW 4X18	O	2		
049	266385-6	TAPPING SCREW 4X14		1	*	
049-1	265B74-2	TAPPING SCREW 4X14	O	1	*	
049-2	266385-6	TAPPING SCREW 4X14	O	1		
050	687169-3	STRAIN RELIEF		1		
051	632F79-5	SWITCH UNIT		1		
052	183C62-2	HANDLE SET		1		
D10		INC. 47				
053	682573-1	CORD GUARD 10		1		
054	695107-1	POWER SUPPLY CORD 1.5-2-2.5		1		
055	811S37-4	GA9081 SERIAL NO. LABEL		1		
056	811S34-0	GA9081 NAME PLATE		1		
057	8038D3-7	CLEAR LABEL		1	*	
058	688131-1	LINE FILTER		1	*	
058-1	688131-1	LINE FILTER	O	1		
A01	143486-6	GRIP 37 COMPLETE		1		
A02	782034-2	LOCK NUT WRENCH 35		1		
A10	122913-6	WHEEL COVER 230CK ASSEMBLY		1		
C10	213017-6	O RING 6		1		
C20	265198-2	+PAN HEAD SCREW M8X25		1		
F07	197476-1	DUST COVER ATTACHMENT SET		1		
F09	192227-7	SUPER FLANGE		1		
F11	194305-9	LOCK NUT RELEASE SOCKET 35 SET		1		
F45	191X44-6	180MM DUST COLLECT COVER K SET		1		

Please state Parts No. when your order.

Print Date 01/05/2024