

Model No.HB350 MAGNETIC DRILL

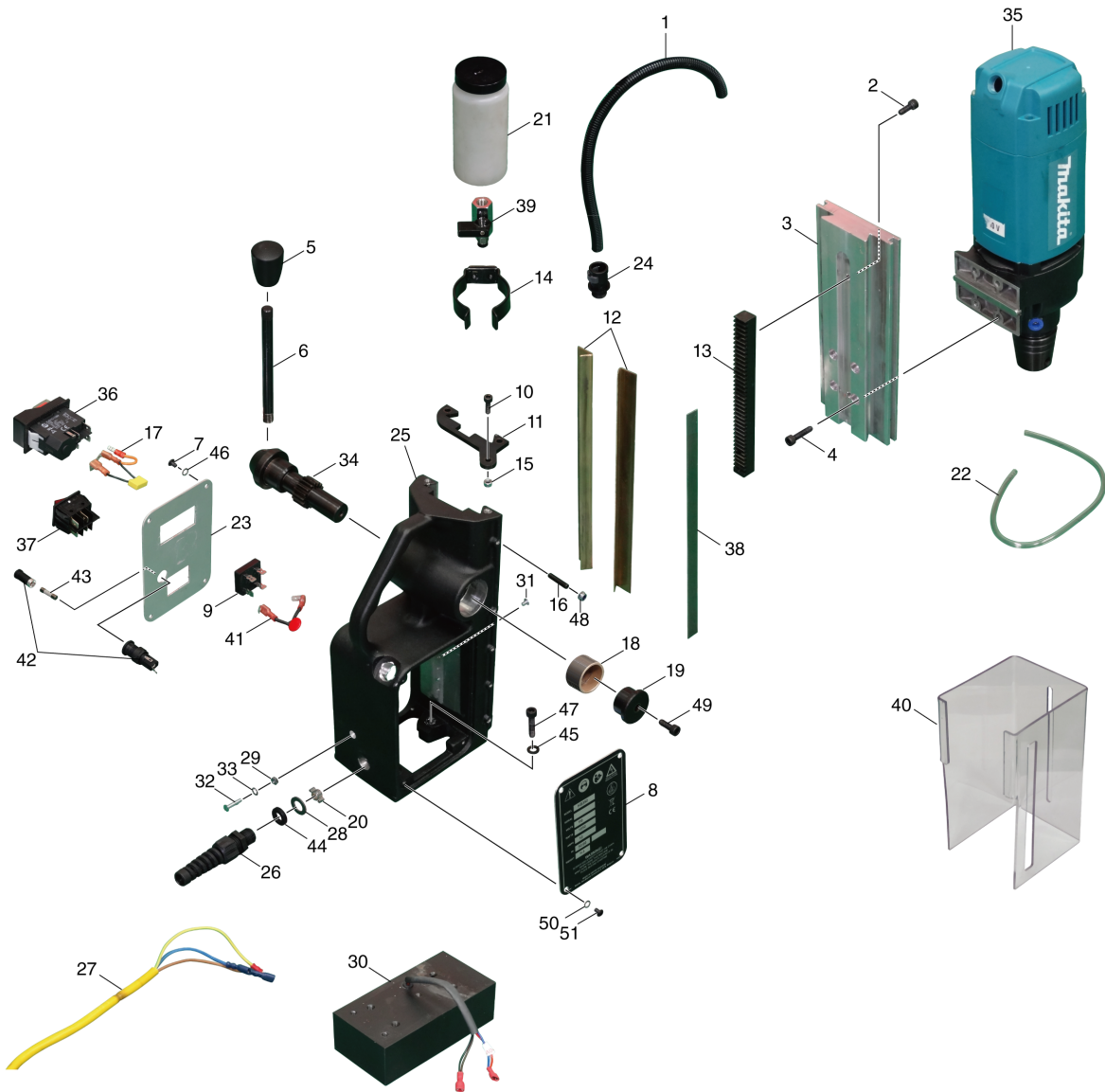

Model No.HB350 MAGNETIC DRILL

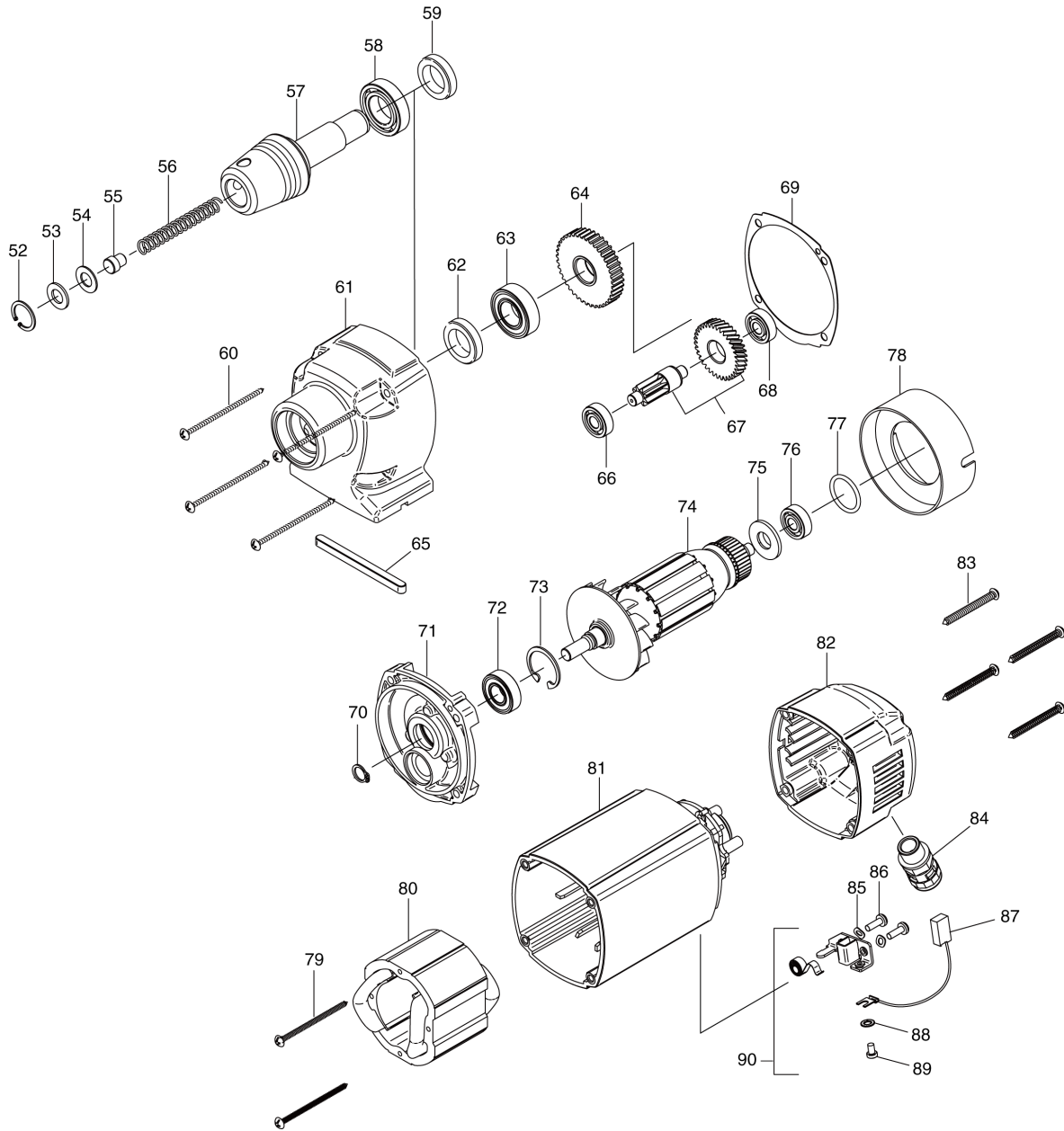

Model No.HB350 MAGNETIC DRILL

| Item | Parts No. | Description | I/C | Qty | New/Old | Opt. 1 | Opt. 2 | Note |
|-------|------------|----------------------------------|-----|-----|---------|--------|--------|------|
| 001 | UD000M0443 | CONDUIT LARGE 12MM | | 1 | | | | |
| 002 | UDSC616CAP | HEX SOCKET HEAD BOLT M6X16 | | 2 | | | | |
| 003 | UD000M1000 | SLIDE | | 1 | | | | |
| 004 | UDSC625CAP | HEX SOCKET HEAD BOLT M6X25 | | 4 | | | | |
| 005 | UD000M0841 | HANDLE KNOB | | 1 | | | | |
| 006 | UD000BD043 | HANDLE(10X130) | | 1 | | | | |
| 007 | UD0SC46BUT | H.S. BUTTON HEAD BOLT M4X6 | | 4 | | | | |
| 008 | UD000M1003 | WARNING PLATE HB350 CE | | 1 | * | | | |
| 008-1 | UD000M1048 | WARNING PLATE HB350 EU | X | 1 | | | | |
| 009 | UD000M0401 | BRIDGE RECTIFIER | | 1 | | | | |
| 010 | UDSC516CAP | HEX SOCKET HEAD BOLT M5X16 | | 3 | | | | |
| 011 | UD00M0811A | BRACKET | | 1 | | | | |
| 012 | UD000M0101 | RAIL | | 2 | | | | |
| 013 | UD000M0831 | RACK | | 1 | | | | |
| 014 | UD0010076C | OIL CUP RETAINING RING | | 1 | | | | |
| 015 | UD0010085B | M5 NYLOC NUT | | 1 | | | | |
| 016 | UD0010085A | M5X25 GRUB SCREW | | 5 | | | | |
| 017 | UD0RD43118 | CAPACITOR | | 1 | * | | | |
| 017-1 | UD000M1100 | CAPACITOR ASSEMBLY | < | 1 | | | | |
| 018 | UD000M0081 | PINION BUSH | | 2 | | | | |
| 019 | UD000M0072 | PINION END CAP (DEEP) | | 1 | | | | |
| 020 | UD0RD47179 | O CLIP | | 1 | | | | |
| 021 | UD0030046A | SMALL OILCUP C/W TAP (BLACK) | | 1 | | | | |
| 022 | UD000BD029 | 6MM OIL PIPE | | 1 | | | | |
| 023 | UD000M1001 | PANEL PLATE | | 1 | | | | |
| 024 | UD00040026 | M16 GLAND | | 1 | | | | |
| 025 | UDM0001BLK | MAIN HOUSING | | 1 | | | | |
| 026 | UD00010231 | M16 STRAIN RELIEF GLAND | | 1 | | | | |
| 027 | UD00CLBL04 | POWER SUPPLY CORD EU | | 1 | * | | | |
| 027-1 | UD00CABL04 | POWER SUPPLY CORD EU | X | 1 | | | | |
| 028 | UD0RD47187 | FLAT WASHER 10 | | 1 | | | | |
| 029 | UDNUT-M4-B | HEX NUT M4 | | 1 | | | | |
| 030 | UD000M1020 | MAGNET BASE | | 1 | | | | |
| 031 | UD0SC46CSK | -COUNTERSUNK HEAD SCREW M4X6 | | 5 | | | | |
| 032 | UDSC412CSK | -COUNTERSUNK HEAD SCREW M4X12 | | 1 | * | | | |
| 032-1 | UD412CSK-B | -COUNTERSUNK HEAD SCREW M4X12 | X | 1 | | | | |
| 033 | UD0SPWR-M4 | TOOTHED LOCK WASHER 4 | | 1 | | | | |
| 034 | UD000M0041 | PINION | | 1 | | | | |
| 035 | UD00EIB523 | DRILL UNIT 230V | | 1 | | | | |
| 036 | UD00NCP002 | SWITCH(230V) | | 1 | | | | |
| 037 | UD00NCP006 | SWITCH | | 1 | | | | |
| 038 | UD000M0441 | PLATE | | 1 | | | | |

Please order the parts with part number.

Print Date 26/10/2023

Model No.HB350 MAGNETIC DRILL

| Item | Parts No. | Description | I/C | Qty | New/Old | Opt. 1 | Opt. 2 | Note |
|-------|------------|-----------------------------|-----|-----|---------|--------|--------|------|
| 039 | UD00050015 | COCK | | 1 | | | | |
| 040 | UD00VISO18 | GUARD | | 1 | | | | |
| 041 | UDW18XC521 | VARISTOR 20MM 275VRMS | | 1 | * | | | |
| 041-1 | UD000M1104 | VARISTOR ASSEMBLY(230V) | < | 1 | | | | |
| 042 | UDW18XC511 | FUSE HOLDER | | 1 | | | | |
| 043 | UDW18XC512 | FUSE | | 1 | | | | |
| 044 | UD00UOD009 | RUBBER WASHER 10 | | 1 | | | | |
| 045 | UD0SPWR-M5 | FLAT WASHER 6 | | 3 | * | | | |
| 045-1 | UD0SPWR-M6 | FLAT WASHER 6 | X | 3 | | | | |
| 046 | UD0SPWR-M4 | TOOTHED LOCK WASHER 4 | | 4 | | | | |
| 047 | UDSC625CAP | HEX SOCKET HEAD BOLT M6X25 | | 3 | | | | |
| 048 | UD0010085B | M5 NYLOC NUT | | 5 | | | | |
| 049 | UDSC616CAP | HEX SOCKET HEAD BOLT M6X16 | | 1 | | | | |
| 050 | UD0SPWR-M4 | TOOTHED LOCK WASHER 4 | | 4 | | | | |
| 051 | UD0SC46BUT | H.S. BUTTON HEAD BOLT M4X6 | | 4 | | | | |
| 052 | UD00EBD030 | CIRCLIP | | 1 | | | | |
| 053 | UD00EBD029 | RUBBER WASHER | | 1 | | | | |
| 054 | UD00EBD028 | WASHER | | 1 | | | | |
| 055 | UD00EBD027 | EJECTION PLUG | | 1 | | | | |
| 056 | UD00EBD026 | COMPRESSION SPRING | | 1 | | | | |
| 057 | UD00EIB528 | SPINDLE | | 1 | | | | |
| 058 | UD00EBD025 | BALL BEARING 6904 2RS | | 1 | | | | |
| 059 | UD00EBD020 | OIL SEAL | | 1 | * | | | |
| 059-1 | UD00EIB184 | OIL SEAL | O | 1 | | | | |
| 060 | UD00EBD022 | TAPPING SCREW 4.8X60 | | 4 | | | | |
| 061 | UD00EBD021 | GEAR CASE | | 1 | | | | |
| 062 | UD00EBD020 | OIL SEAL | | 1 | * | | | |
| 062-1 | UD00EIB184 | OIL SEAL | O | 1 | | | | |
| 063 | UD00UDC004 | BALL BEARING 6003 2RS | | 1 | | | | |
| 064 | UD00EBD019 | SPINDLE GEAR | | 1 | | | | |
| 065 | UD000M1019 | KEY | | 1 | | | | |
| 066 | UD00UDC022 | GROOVED BALL BEARING 608ZZ | | 1 | | | | |
| 067 | UD00EBD018 | INTERNAL SHAFT ASSY | | 1 | | | | |
| 068 | UD00UDC022 | GROOVED BALL BEARING 608ZZ | | 1 | | | | |
| 069 | UD00EBD017 | GASKET | | 1 | | | | |
| 070 | UD00EBD016 | CIRCLIP | | 1 | | | | |
| 071 | UD00EBD015 | GEAR CASE COVER | | 1 | | | | |
| 072 | UD00UDC023 | GROOVED BALL BEARING 6001ZZ | | 1 | | | | |
| 073 | UD00EBD014 | CIRCLIP | | 1 | | | | |
| 074 | UDEBD013-B | ARMATURE 230V | | 1 | | | | |
| 075 | UD00EBD012 | INSULASION WASHER | | 1 | | | | |

Please order the parts with part number.

Print Date 26/10/2023

Model No.HB350 MAGNETIC DRILL

| Item | Parts No. | Description | I/C | Qty | New/Old | Opt. 1 | Opt. 2 | Note |
|------|------------|-------------------------------|-----|-----|---------|--------|--------|------|
| 076 | UD00UDC022 | GROOVED BALL BEARING 608ZZ | | 1 | | | | |
| 077 | UD00EBD011 | O-RING | | 1 | | | | |
| 078 | UD00EBD010 | BAFFLE PLATE | | 1 | | | | |
| 079 | UD00EBD009 | TAPPING SCREW 3.9X60 | | 2 | | | | |
| 080 | UDEBD008-B | FIELD 230V | | 1 | | | | |
| 081 | UD00EIB526 | MOTOR HOUSING | | 1 | | | | |
| 082 | UD00EIB527 | REAR COVER | | 1 | | | | |
| 083 | UD00EBD005 | TAPPING SCREW 4.8X45 | | 4 | | | | |
| 084 | UD00040025 | PLUG B | | 1 | | | | |
| 085 | UD00EBD004 | WAVE WASHER 4 | | 2 | | | | |
| 086 | UD00EBD003 | PAN HEAD SCREW M4X12 | | 2 | | | | |
| 087 | UD00EBD002 | CARBON BRUSH | | 2 | | | | |
| 088 | UD00EBD031 | TOOTHED LOCK WASHER 4 | | 2 | | | | |
| 089 | UD00EBD032 | ROUND HEAD SCREW | | 2 | | | | |
| 090 | UD00EBD001 | BRUSH HOLDER ASSY | | 1 | | | | |
| 091 | UD00PL1889 | MAKITA LOGO LABEL | | 1 | | | | |
| A01 | UD00CASE50 | CARRY CASE | | 1 | | | | |
| A02 | UD000KEY01 | KEY 2.5MM | | 1 | | | | |
| A03 | UD000KEY03 | KEY 4MM | | 1 | | | | |
| A04 | UD000KEY04 | KEY 5MM | | 1 | | | | |
| A05 | UD0STRAP01 | STRAP | | 1 | | | | |

Please order the parts with part number.

Print Date 26/10/2023