

Model No.HM1801 ELECTRIC BREAKER

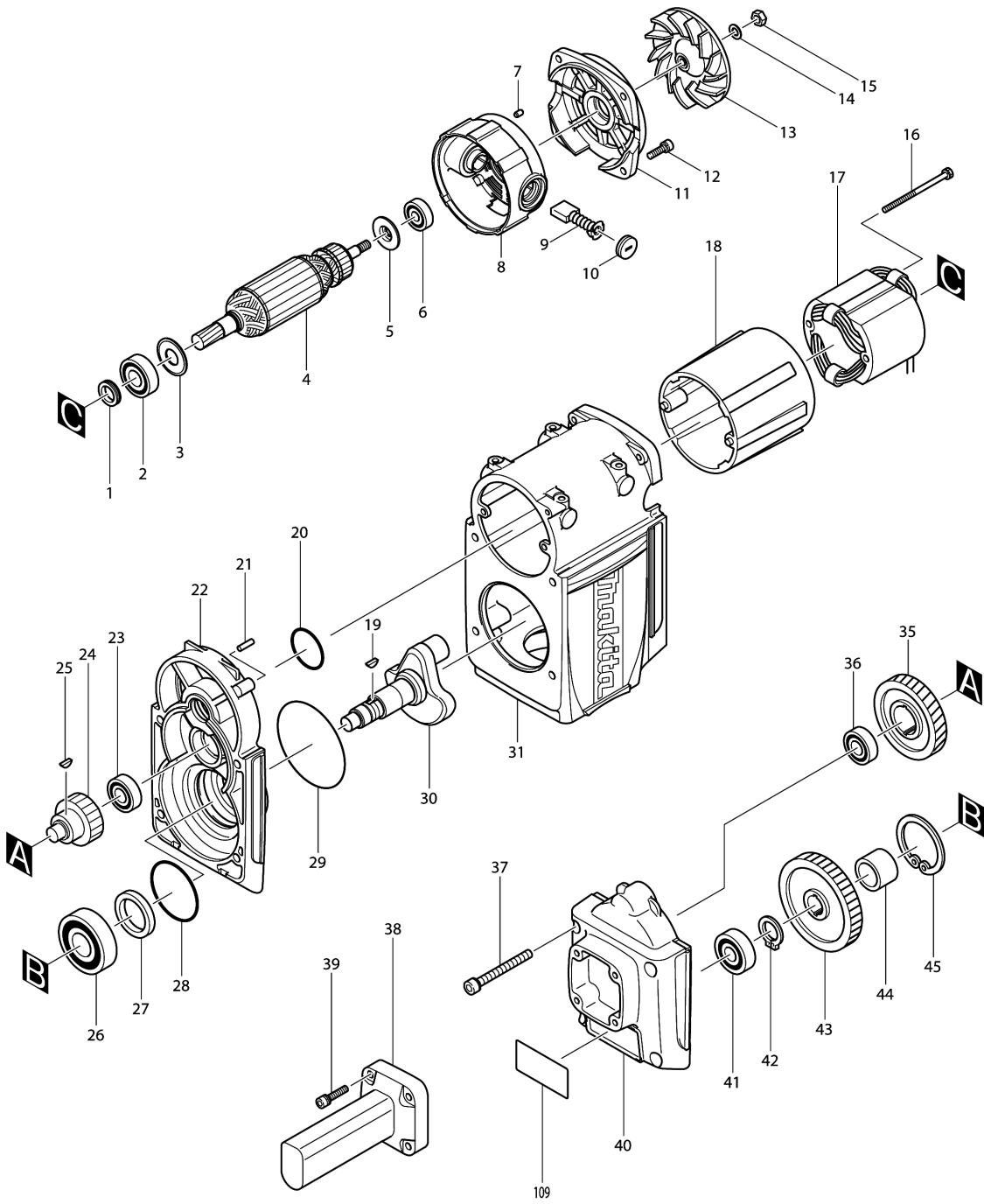

# Model No.HM1801 ELECTRIC BREAKER

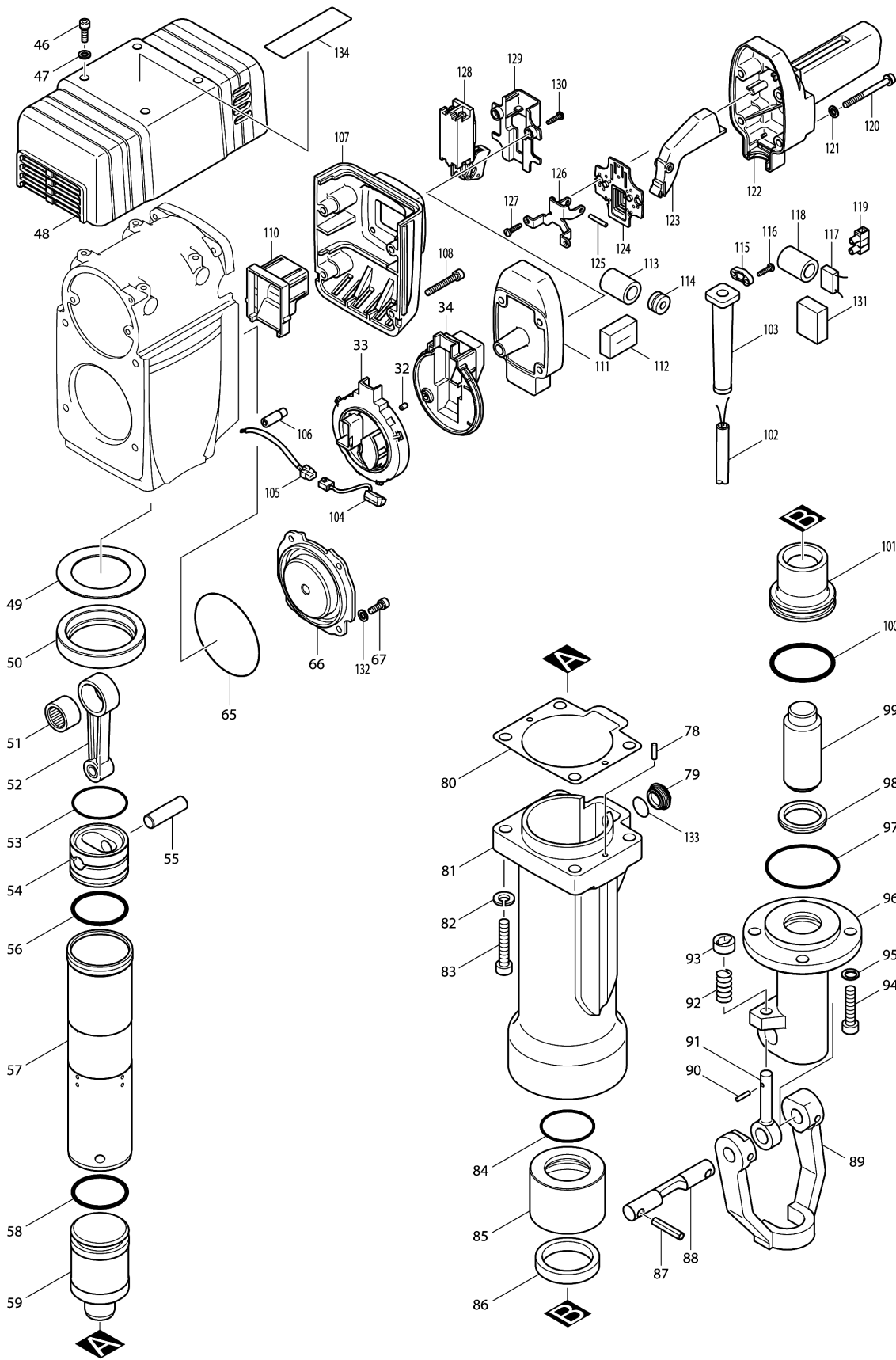

Model No.HM1801 ELECTRIC BREAKER

Item	Parts No.	Description	I/C	Qty	New/Old	Opt. 1	Opt. 2	Note
001	322566-3	SCREW SEAL		1				
002	211256-2	BALL BEARING 6203LLB		1				
003	267706-5	WASHER 17		1				
004	516922-9	ARMATURE ASS'Y 200-240V		1				
D10		INC. 1-3,5,6						
005	681646-7	INSULATION WASHER		1				
006	211066-7	BALL BEARING 6200LLB		1	*			
006-1	211087-9	BALL BEARING 6200DDW	<	1				
007	263002-9	RUBBER PIN 4		4				
008	154586-7	MOTOR HOUSING B COMPLETE		1				
C10	414665-6	FIX RING		2				
C20	643711-0	BRUSH HOLDER		2				
009	191957-7	A.C. CARBON BRUSH CB-204		1				
010	643710-2	BRUSH HOLDER CAP		2				
011	317899-9	BEARING BOX		1				
012	265366-7	HEX. SOCKET HEAD BOLT M6X22		4				
013	240024-6	FAN 100		1				
014	253165-9	FLAT WASHER 8		1				
015	931402-8	HEX. NUT M8		1				
016	265344-7	+ HEX. BOLT M5X85		2				
017	628943-0	FIELD 240V		1				
018	414787-2	MOTOR HOUSING A		1				
019	254001-2	WOODRUFF KEY 4		2				
020	213507-9	O RING 40		1				
021	256151-9	PIN 5		1				
022	154585-9	GEAR HOUSING COMPLETE		1				
D10		INC. 20,28						
023	211209-1	BALL BEARING 6202		1				
024	226251-9	SPUR GEAR 22		1				
025	254001-2	WOODRUFF KEY 4		2				
026	211361-5	BALL BEARING 6305LLB		1				
027	213476-4	OIL SEAL 35		1				
028	213721-7	O RING 61		1				
029	213806-9	O RING 90		1				
030	324544-9	CRANK SHAFT		1				
031-1	318027-9	CRANK HOUSING		1				
032	263002-9	RUBBER PIN 4		1				
033-1	419262-3	CRANK HOUSING CAP		1				
034-1	419263-1	CAP COVER		1				
035	221793-8	HELICAL GEAR 50		1				
036	211209-1	BALL BEARING 6202		1				
037	922496-4	HEX. SOCKET HEAD BOLT M8X75		4				
038	418415-1	SIDE HANDLE		1				
039	922353-6	HEX.SOCKET HEAD BOLT M6X30		4				

Please order the parts with part number.

Print Date 4/12/2023

Model No.HM1801 ELECTRIC BREAKER

Item	Parts No.	Description	I/C	Qty	New/Old	Opt. 1	Opt. 2	Note
040	317902-6	GEAR HOUSING COVER		1				
041	211214-8	BALL BEARING 6302		1				
042	961060-6	RETAINING RING S-20		1				
043	226242-0	SPUR GEAR 47		1				
044	331416-1	SLEEVE 25		1				
045	962301-3	RETAINING RING R-62		1				
046	922331-6	HEX. SOCKET HEAD BOLT M6X20		4				
047	941152-7	FLAT WASHER 6		4				
048-1	419324-7	MOTOR HOUSING COVER		1				
049	267296-8	FLAT WASHER 63		1				
050	324580-5	SPACER		1				
051	212358-7	NEEDLE BEARING 2520		1				
052	322476-4	CONNECTING ROD		1				
053	213662-7	O RING 55		1				
054	324536-8	PISTON		1				
055	268130-5	PIN 15		1				
056	213666-9	O RING 52		1				
057	331694-3	CYLINDER LINER 62		1				
058	213666-9	O RING 52		1				
059	324546-5	STRIKER		1				
065	213855-6	O RING 95		1				
066	419001-1	CRANK CAP		1				
067	922331-6	HEX. SOCKET HEAD BOLT M6X20		4				
078	256151-9	PIN 5		1				
079	324606-3	CAP		1	*			
079-1	450347-6	CAP	S	1				
080	162241-7	GASKET		1				
081	317917-3	BARREL		1				
082	942301-9	SPRING WASHER 12		4				
083	922677-0	HEX. SOCKET BOLT M12X55		4				
084	213660-1	O RING 53		1				
085	322548-5	CYLINDER B		1				
086	262050-5	RUBBER RING 54		1				
087	951272-9	SPRING PIN 8-40		2				
088	324238-6	TOOL RETAINER SHAFT		1				
089	324236-0	TOOL RETAINER		1				
090	256219-1	PIN 4		2				
091	322477-2	TOOL RETAINER POLE		2				
092	233083-7	COMPRESSION SPRING 12		2				
093	322560-5	RETAINER RING		2				
094	265989-1	HEX. SOCKET BOLT M12X45		4				
095	253989-3	SPRING WASHER 12		4				
096	324539-2	TOOL HOLDER 29		1				
097	213755-0	O RING 75		1				

Please order the parts with part number.

Print Date 4/12/2023

Model No.HM1801 ELECTRIC BREAKER

Item	Parts No.	Description	I/C	Qty	New/Old	Opt. 1	Opt. 2	Note
098	213517-6	X RING 40		1				
099	324545-7	IMPACT BOLT		1				
100	213667-7	O RING 60		1				
101	324541-5	IMPACT BOLT HOLDER		1				
102	695123-3	POWER SUPPLY CORD 1.5-2-4.0		1				
103	682546-4	CORD GUARD 12-125		1				
104	631671-8	PILOT LAMP		1				
105	638378-7	LEAD UNIT		1				
106	418951-7	LENS		1				
107	317901-8	REAR CASE		1				
108	922366-7	HEX. SOCKET HEAD BOLT M6X45		4				
109	861404-9	HM1801 NAME PLATE		1	*			
109-1	858S81-0	HM1801 NAME PLATE	O	1				
110	418954-1	TOP COVER		1				
111	419044-3	HANDLE SUB BASE		1				
112	685700-9	SPONGE SHEET		1				
113	685722-9	SPONGE		1				
114	688131-1	LINE FILTER		1	*			
114-1	688131-1	LINE FILTER	O	1				
115	687053-2	STRAIN RELIEF		1				
116	265995-6	TAPPING SCREW 4X18		2				
117	645200-1	NOISE SUPPRESSOR		1				
118	685722-9	SPONGE		1				
119	654554-5	TERMINAL BLOCK		2				
120	265535-0	HEX.SOCKET HEAD BOLT M6X65		4				
121	941152-7	FLAT WASHER 6		4				
122	418333-3	HANDLE		1				
123	418332-5	SWITCH LEVER		1				
124	421850-4	DUST PLATE		1				
125	256206-0	PIN 4		1				
126	345355-9	SUPPORT		1				
127	265995-6	TAPPING SCREW 4X18		2				
128	651131-4	SWITCH C3D-15MS		1				
129	419045-1	SWITCH COVER		1				
130	265995-6	TAPPING SCREW 4X18		2				
131	685718-0	SPONGE SHEET		1				
132	941152-7	FLAT WASHER 6		4				
133	213373-4	O RING 22		1	*			
133-1	213953-6	O RING 24	S	1				
135	265995-6	TAPPING SCREW 4X18		1				
136	424132-3	CAP RUBBER		2				
137	819352-6	CLEAR LABEL		1	*			
A01	783203-8	HEX. WRENCH 5		1				
B01	195205-6	HAMMER SERVICE KIT		1				

Please order the parts with part number.

Print Date 4/12/2023

Model No.HM1801 ELECTRIC BREAKER

Item	Parts No.	Description	I/C	Qty	New/Old	Opt. 1	Opt. 2	Note
C10	181490-7	HAMMER GREASE 30G		2				
D10		INC. 9,56,58,84,98,100						
F08	197148-8	DUST EXTRACTOR ATTACHMENT SET		1				
F10	197168-2	DUST EXTRACTOR ATTACHMENT SET		1				

Please order the parts with part number.

Print Date 4/12/2023