

Model No.HP1641 HAMMER DRILL 16MM

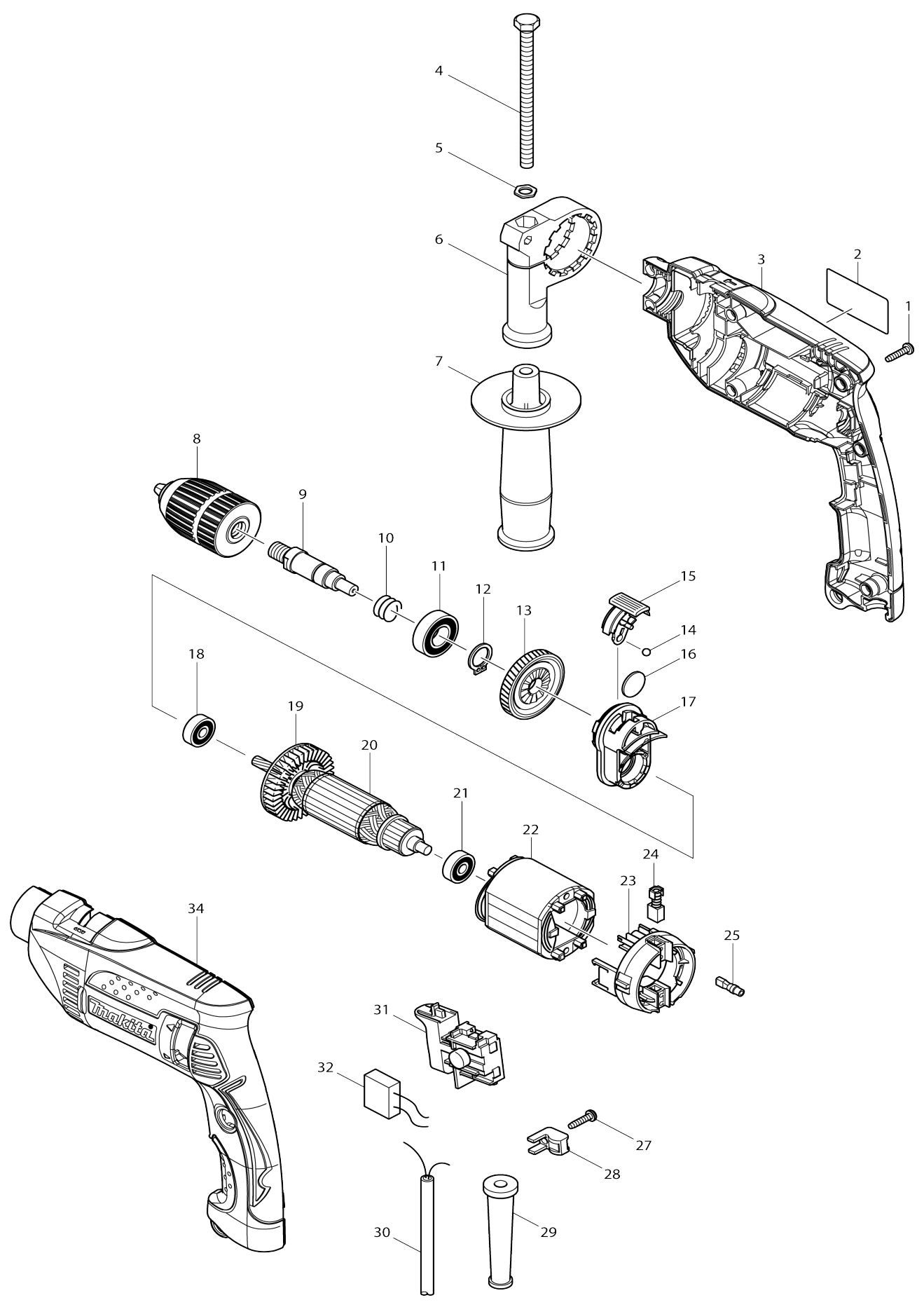

Model No.HP1641 HAMMER DRILL 16MM

Item No.	Parts No.	Description	Interc hang eability	Q'ty	New/ Old	Note1	Note2
001	265995-6	TAPPING SCREW 4X18		7			
002	866006-6	HP1641 NAME PLATE		1			
003	188611-2	HOUSING SET		1	*		
C10	345399-9	PLATE		2	*		
D10		INC. 34					
003-1	183U71-9	HOUSING SET	S	1			
C10	345399-9	PLATE		2			
D10		INC. 34					
004	265583-9	HEX. BOLT M8X120		1			
005	345280-4	HEX. WASHER		1			
006	417630-4	GRIP BASE		1			
007	152489-9	GRIP 36 COMPLETE		1			
008-1	196193-0	KEYLESS DRILL CHUCK		1	*		
008-2	196564-1	KEYLESS DRILL CHUCK	O	1	*		
008-3	196193-0	KEYLESS DRILL CHUCK	<	1			
009	324397-6	SPINDLE		1			
010	233389-3	COMPRESSION SPRING 15		1			
011	211201-7	BALL BEARING 6002LLB		1			
012	961055-9	RETAINING RING S-15		1			
013	226579-5	HELICAL GEAR 45		1			
014	216018-3	STEEL BALL 5.0		1			
015	418319-7	CHANGE LEVER		1			
016	345354-1	PLATE 19		1			
017-1	141165-0	CAM HOLDER COMPLETE		1			
018	210023-2	BALL BEARING 627DDW		1			
019	240067-8	FAN 55		1			
020	517458-1	ARMATURE ASS'Y 220-240V		1			
D10		INC. 18,19,21					
021	211028-5	BALL BEARING 627LB		1			
022	633568-7	FIELD 220-240V		1			
023	638237-5	BRUSH HOLDER UNIT		1	*		
023-1	632542-6	BRUSH HOLDER UNIT	S	1			
024	191962-4	CARBON BRUSH CB-419		1			
025	686038-5	RECEPTACLE SLEEVE		2			
027	265995-6	TAPPING SCREW 4X18		1			
028	687260-7	STRAIN RELIEF		1			
029	682502-4	CORD GUARD 8-85		1			
030	665383-1	POWER SUPPLY CORD 1.0-2-2.0		1			
031	650570-5	SWITCH TG843TB-2		1			
032-1	645267-9	NOISE SUPPRESSOR		1			
034	188611-2	HOUSING SET		1	*		
C10	345399-9	PLATE		2	*		
D10		INC. 3					
034-1	183U71-9	HOUSING SET	S	1			
C10	345399-9	PLATE		2			
D10		INC. 3					
A01	324219-0	DEPTH GAUGE		1			

A02	821549-5	CONNECTOR PLASTIC CASE (TYPE1)		1			
C10	453974-8	LATCH		4			
A03	837666-1	INNER TRAY		1	*		
A03-1	838038-3	INNER TRAY	<	1			
A04	801C94-4	HP1641J INDICATION LABEL		1			
A05	801C95-2	HP1641J PLASTIC CASE LABEL		2			
E04	646173-1	CHOKE COIL		1			
E05	646172-3	CHOKE COIL		1			

Please state Parts No. when your order.

Print Date 10/25/2023