

Model No.HR3200C ROTARY HAMMER 32MM

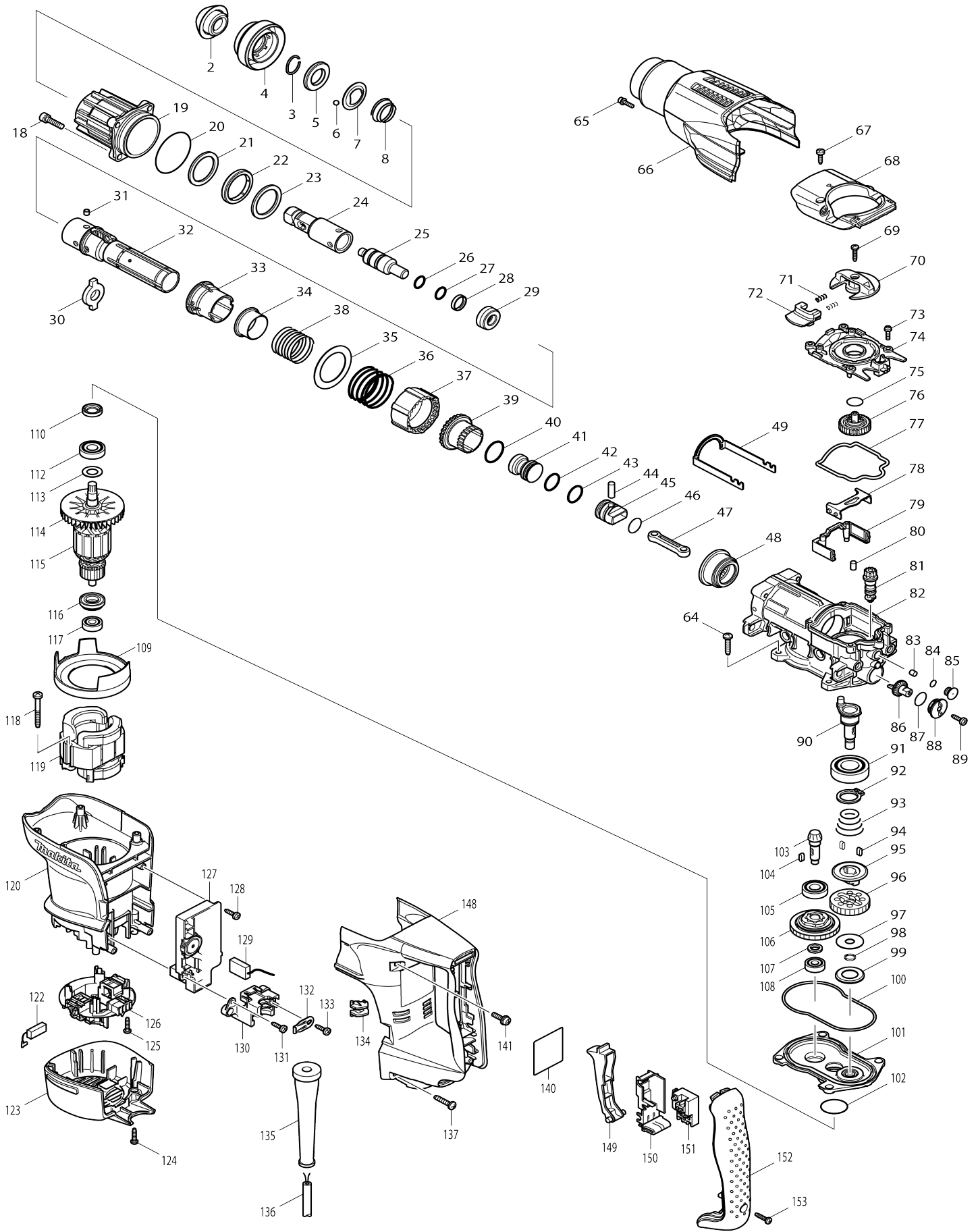

Model No.HR3200C ROTARY HAMMER 32MM

Item No.	Parts No.	Description	Interchangability	Q'ty	New/Old	Note1	Note2
002	286282-0	TOOL HOLDER CAP		1			
003	233940-9	RING SPRING 19		1			
004	450245-4	CHUCK COVER		1			
005	257288-5	RING 21		1			
006	216022-2	STEEL BALL 7.0		2			
007	345873-7	GUIDE WASHER		1			
008	234049-0	CONICAL COMPRESSIONSPRING 22-32		1			
018	922341-3	HEX. SOCKET HEAD BOLT M6X25		4			
019	158533-0	BARREL COMPLETE		1			
C10	213436-6	OIL SEAL 28		1			
C20	213516-8	O RING 36		1	*		
C21	213142-3	O-RING 35	O	1			
020	213656-2	O RING 53		1			
021	267810-0	FLAT WASHER 34		1			
022	262138-1	URETHAN RING 34		1			
023	267810-0	FLAT WASHER 34		1			
024	324840-5	TOOL HOLDER		1			
025	324849-7	IMPACT BOLT		1			
026	213228-3	O RING 15		1			
027	213228-3	O RING 15		1			
028	213321-3	FLUORO CARBON RESIN RING 20		1			
029	424062-8	RUBBER RING 13		1			
030	324838-2	SLIDE PLATE		1			
031	256266-2	PIN 6		4			
032	331794-9	CYLINDER 25		1			
033	450243-8	SLIDE SLEEVE		1			
034	331805-0	RING 29		1			
035	267360-5	FLAT WASHER 40		1			
036	234052-1	COMPRESSION SPRING 42		1			
037	450236-5	LOCK SLEEVE		1			
038	234050-5	COMPRESSION SPRING 34		1			
039	331795-7	DRIVING SLEEVE		1			
040	213434-0	O RING 26		1			
041	324858-6	STRIKER		1			
042	213283-5	O-RING 18		1			
043	213283-5	O-RING 18		1			
044	256087-2	PIN 7		1			
045	324918-4	PISTON		1			
046	213262-3	O RING 18		1			
047	450235-7	CONECTING ROD		1			
048	227531-6	SPIRAL BEVEL GEAR 37		1			
049	345867-2	LINK ARM		1			
064	266041-8	TAPPING SCREW 5X25		4			
065	922123-3	HEX. SOCKET HEAD BOLT M4X14		1			
066	450261-6	CRANK HOUSING COVER		1			
067	266192-7	TAPPING SCREW 4X14		2			
068	318201-9	CRANK CAP COVER		1			

069	265995-6	TAPPING SCREW 4X18		1			
070	450249-6	CHANGE LEVER		1			
071	233436-0	COMPRESSION SPRING 3		2			
072	450250-1	LOCK BUTTON		1			
073	911128-8	P.H.SCREW M4X16 WITH WR		5			
074	450241-2	CRANK CAP		1			
075	213223-3	O RING 16		1			
076	158437-6	SPUR GEAR 33 COMPLETE		1			
077	424064-4	SEAL RING B		1			
078	345868-0	LINK PLATE		1			
079	450247-0	AIR PIPE		1	*		
079-1	453866-1	AIR PIPE	<	1			
080	263005-3	RUBBER PIN 6		2			
081	450242-0	GEAR SHAFT		1	*		
081-1	452126-8	GEAR SHAFT	S	1			
082	158532-2	CRANK HOUSING COMPLETE		1	*		
C10	213579-4	O-RING 44		1	*		
082-1	158713-8	CRANK HOUSING COMPLETE	O	1	*		
C10	213579-4	O-RING 44		1	*		
082-2	158713-8	CRANK HOUSING COMPLETE	O	1			
C10	213579-4	O-RING 44		1			
083	443138-2	FILTER		1			
084	213030-4	O RING 8		1			
085	450238-1	FILTER CAP		1			
086	450244-6	CRANK GEAR		1			
087	213223-3	O RING 16		1	*		
087-1	213176-6	O RING 14	<	1			
088	450237-3	CAP HOLDER		1			
089	266192-7	TAPPING SCREW 4X14		1			
090	324839-0	CRANK SHAFT		1			
091	211332-2	BALL BEARING 6004LLU		1			
092	961060-6	RETAINING RING S-20		1			
093	231991-6	CONICAL COMP. SPRING 21-31		1			
094	254239-9	KEY 4		2			
095	324848-9	CLUTCH		1			
096	227188-3	SPUR GEAR 33		1			
097	253197-6	FLAT WASHER 10		1			
098	961036-3	RETAINING RING WR-10		1			
099	345869-8	CUP WASHER 18		1			
100	424063-6	SEAL RING A		1			
101	158534-8	GEAR HOUSING COMPLETE		1			
102	213415-4	O RING 28		1			
103	227533-2	SPIRAL BEVEL GEAR 9		1			
104	254239-9	KEY 4		1			
105	210105-0	BALL BEARING 6001LLU		1			
106	125421-6	TORQUE LIMITER ASS'Y		1			
107	257291-6	RING 10		1			
108	210005-4	BALL BEARING 608DDW		1			
109	450251-9	BAFFLE PLATE		1			
110	213133-4	OIL SEAL 12		1			
112	210105-0	BALL BEARING 6001LLU		1			

113	253084-9	FLAT WASHER 12		1		
114	241863-7	FAN 70		1		
115	513748-0	ARMATURE ASS'Y 220-240V		1		
D10		INC. 112-114,116,117				
116	681650-6	INSULATION WASHER		1		
117	210005-4	BALL BEARING 608DDW		1		
118	266056-5	TAPPING SCREW 5X45		2		
119	625813-4	FIELD 220-240V		1		
120	450252-7	MOTOR HOUSING		1		
122	194160-9	CARBON BRUSH CB-350		1		
123	450253-5	REAR COVER		1		
124	265995-6	TAPPING SCREW 4X18		2		
125	265995-6	TAPPING SCREW 4X18		4		
126	638519-5	BRUSH HOLDER UNIT		1		
127	631784-5	CONTROLLER		1		
128	266192-7	TAPPING SCREW 4X14		1	*	
128-1	266901-4	TAPPING SCREW 4X14	<	1		
129	638406-8	LEAD UNIT		1		
130	450246-2	CORD CLAMP BASE		1		
131	266192-7	TAPPING SCREW 4X14		1	*	
131-1	266901-4	TAPPING SCREW 4X14	<	1		
132	687169-3	STRAIN RELIEF		1		
133	266192-7	TAPPING SCREW 4X14		1		
134	450240-4	LENS		1		
135	682560-0	CORD GUARD 10		1		
136	695123-3	POWER SUPPLY CORD 1.5-2-4.0		1		
137	266041-8	TAPPING SCREW 5X25		2		
140	864532-9	HR3200C NAME PLATE		1	*	
140-1	8580L4-8	HR3200C NAME PLATE	O	1		
141	911233-1	PAN HEAD SCREW M5X20		2		
148	450262-4	HANDLE		1		
149	419025-7	SWITCH LEVER		1		
150	154626-1	SWITCH HOLDER COMPLETE		1		
151	650567-4	SWITCH TG73B-1		1	*	
151-1	650676-9	SWITCH C3PA-1111	<	1		
152	450257-7	HANDLE COVER		1		
153	265995-6	TAPPING SCREW 4X18		1		
154	267383-3	FLAT WASHER 22		1		
155	267721-9	WAVE WASHER 15		1		
156	213083-3	O RING 9		1		
A01	181573-3	GREASE VESSEL 93G		1	*	
A01-1	194683-7	GREASE VESSEL SET	O	1	*	
A01-2	198993-4	GREASE VESSEL SET	<	1		
A02	135197-7	GRIP 36 ASS'Y		1		
C10	265701-9	THUMB SCREW M6X14		1		
C20	266163-4	CUP SQUARE NECK BOLT M8X80		1		
C30	321248-4	DEPTH GAUGE		1		
C40	344492-6	PLATE		1		
C50	344811-6	GRIP SPRING 63		1		
C60	417026-9	SIDE GRIP BASE 63		1		
C70	931302-2	HEX. NUT M6		1		
A03	824819-1	PLASTIC CARRYING CASE		1		

C10	163467-4	LATCH		2			
A04	810409-6	CAUTION CARD		1			
A05	806474-1	HR3200C MODEL NO.LABEL		1			
B01	195199-5	HAMMER SERVICE KIT SET		1			
C10	181490-7	HAMMER GREASE 30G		1			
D10		INC. 2,3,6,7,26-28,42,43,46,					
D20		INC. 122					

Please state Parts No. when your order.

Print Date 12/09/2023