

Model No.HTR4900 ENGINE HEDGE TRIMMER

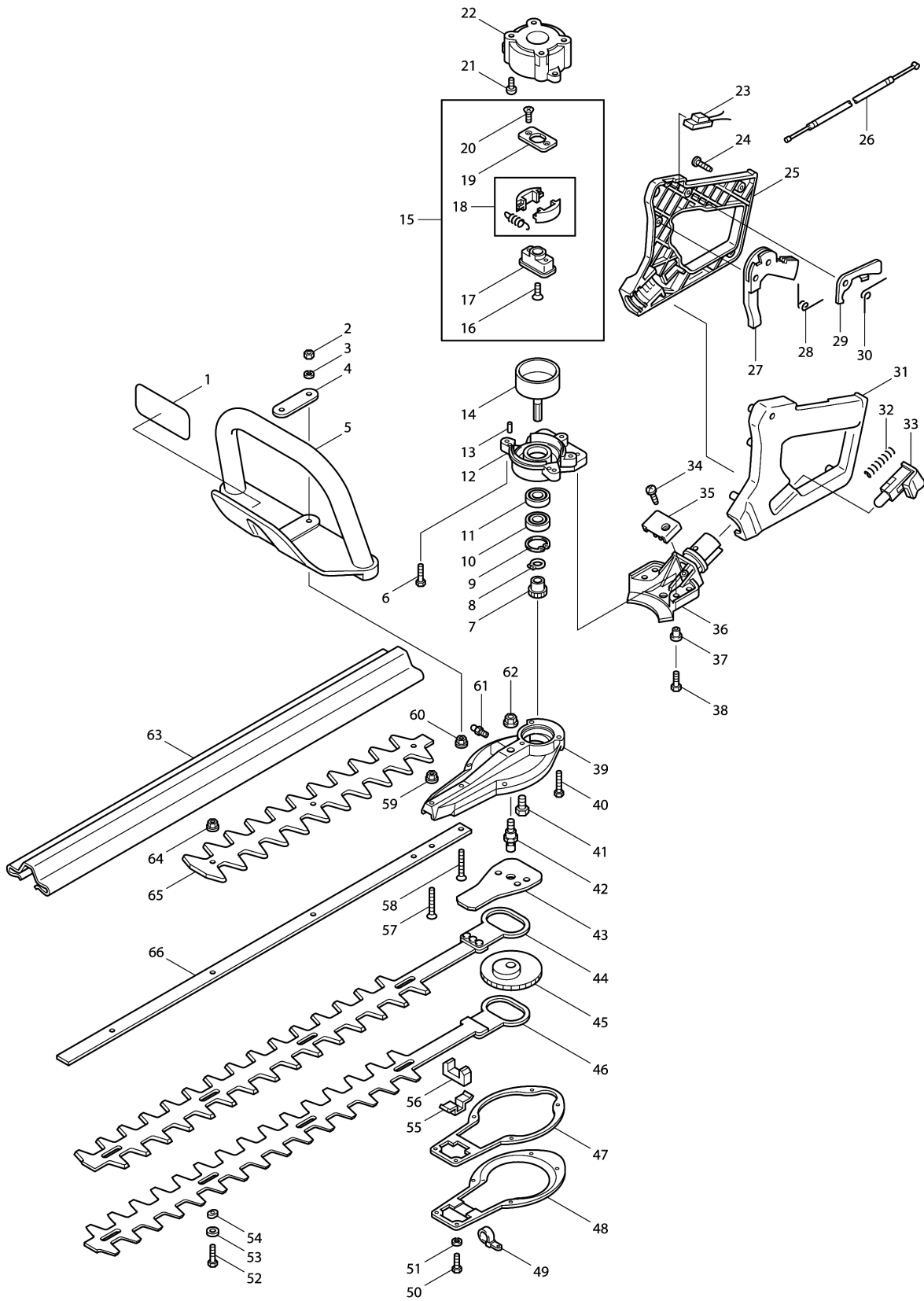

Model No.HTR4900 ENGINE HEDGE TRIMMER

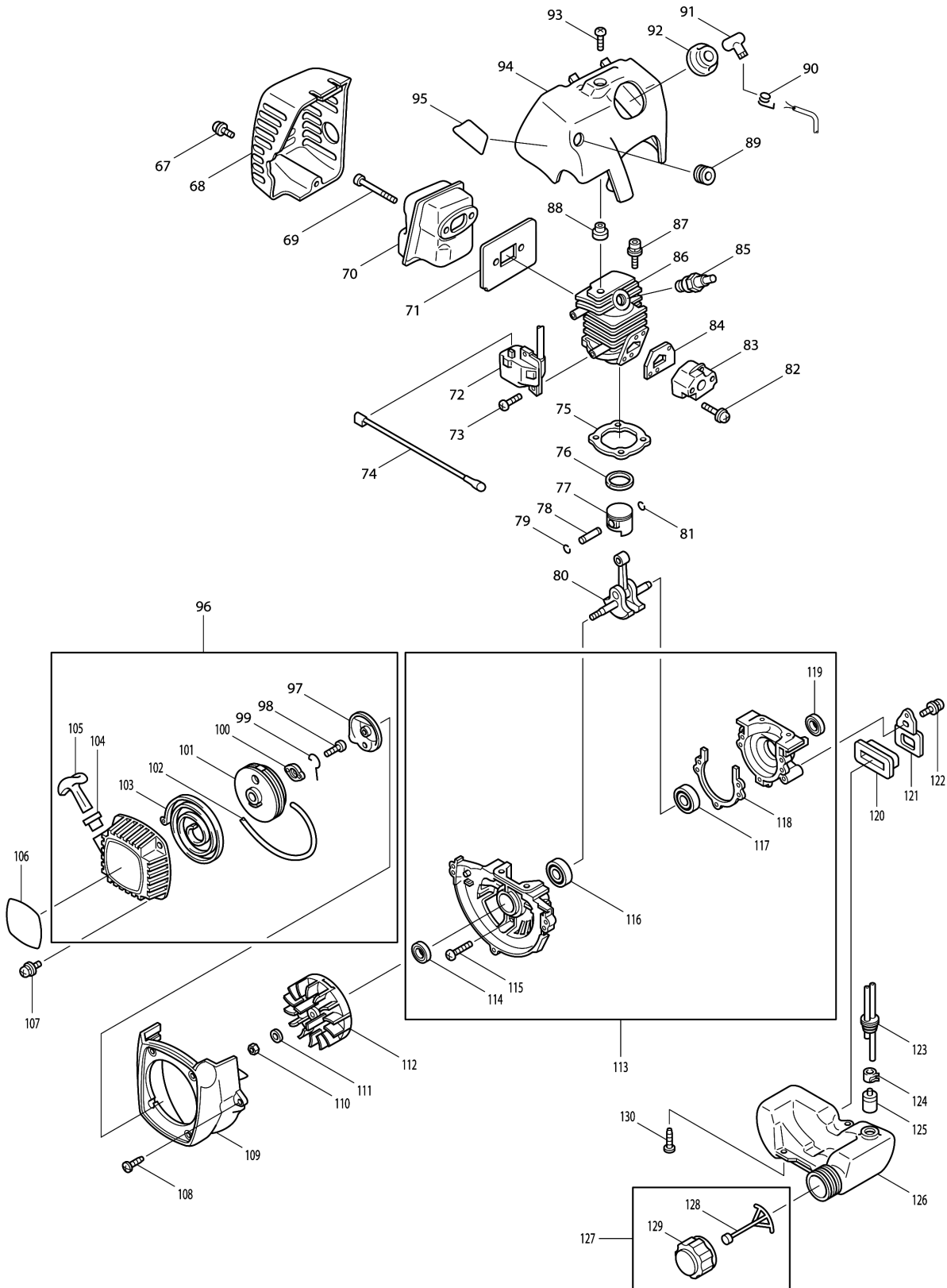

Model No.HTR4900 ENGINE HEDGE TRIMMER

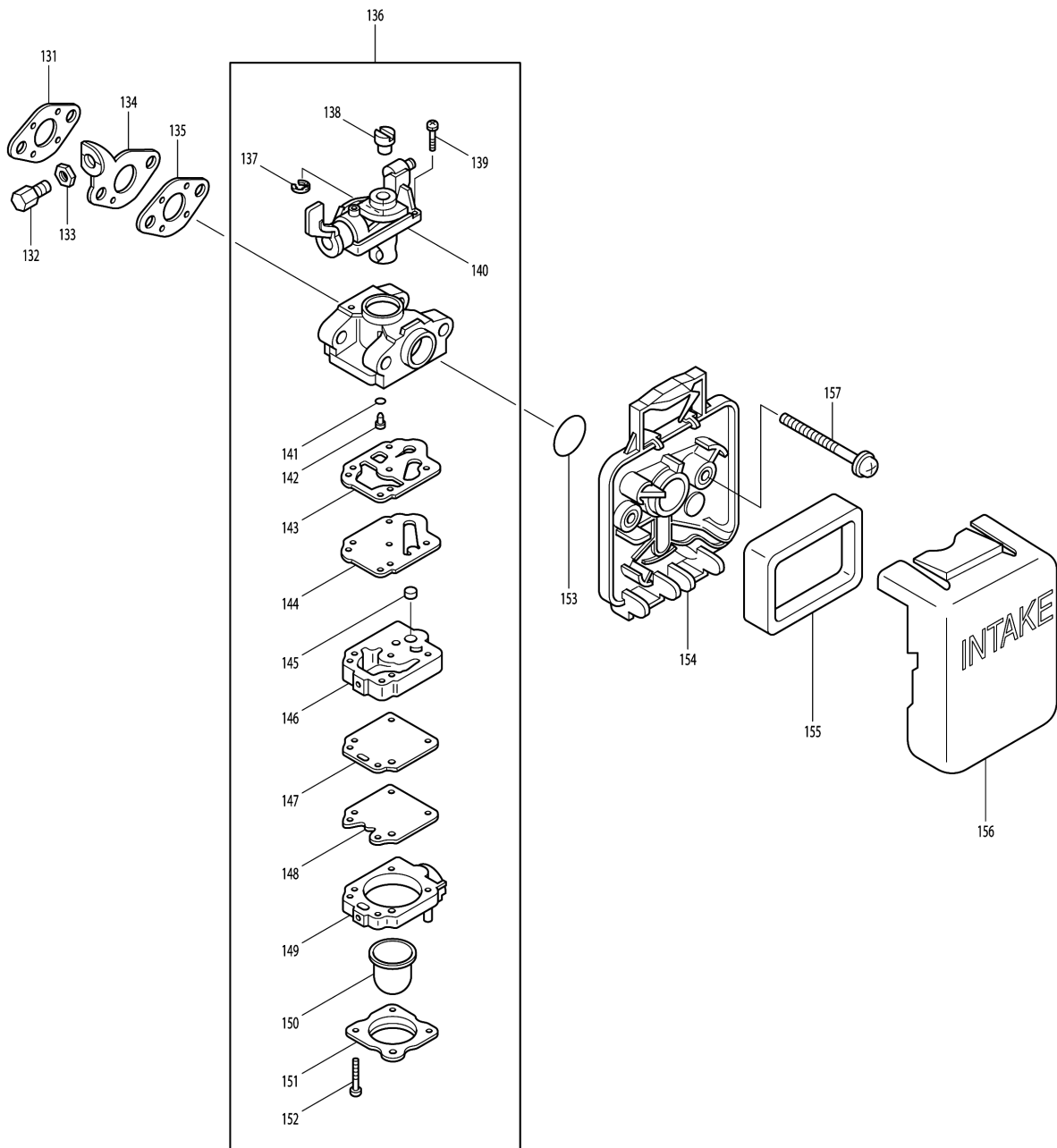

Model No.HTR4900 ENGINE HEDGE TRIMMER

Item	Parts No.	Description	I/C	Qty	New/Old	Opt. 1	Opt. 2	Note
001	0736359980	CAUTION LABEL		1				
002	0300516000	NYRON NUT		2	*			
002-1	030051600N	NYLON NUT	O	2				
003	0320500000	SPRING WASHER		2	*			
003-1	032050000N	SPRING WASHER 5	O	2				
004	3033311000	FRONT HANDLE PLATE		1	*			
004-1	303331100N	FRONT HANDLE PLATE	O	1	*			
004-2	346756-4	FRONT HANDLE PLATE	O	1				
005	3033301000	FRONT HANDLE		1	*			
005-1	303330100N	FRONT HANDLE	O	1				
006	0650520000	TORX SCREW M5X20		3	*			
006-1	065052000N	TORX SCREW M5X20	O	3	*			
006-2	XNR0000098	TORX SCREW M5X20	O	3				
007	3033553000	GEAR		1	*			
007-1	303355300N	GEAR	O	1				
008	0450012020	SNAP RING		1	*			
008-1	045001202N	SNAP RING S-12	O	1	*			
008-2	XNR0000067	SNAP RING S-12	O	1				
009	0450028000	SNAP RING		1	*			
009-1	045002800N	SNAP RING R-28	O	1	*			
009-2	XNR0000073	SNAP RING R-28	O	1				
010	0356001030	BALL BEARING #6001LL		1	*			
010-1	035600103N	BALL BEARING 6001LL	O	1	*			
010-2	XNR0000053	BALL BEARING 6001LL	O	1				
011	0356001030	BALL BEARING #6001LL		1	*			
011-1	035600103N	BALL BEARING 6001LL	O	1	*			
011-2	XNR0000053	BALL BEARING 6001LL	O	1				
012	3703551000	FLANGE		1	*			
012-1	370355100N	FLANGE	O	1				
013	0480412000	PIN		1	*			
013-1	048041200N	PIN	O	1	*			
013-2	XNR0000076	PIN	O	1				
014	3035552000	CLUTCH DRUM		1	*			
014-1	303555200N	CLUTCH DRUM	O	1				
015	3705400000	CLUTCH ASSY		1	*			
D10		INC. 16-20			*			
015-1	370540000N	CLUTCH ASS'Y	O	1				
D10		INC. 16-20						
016	0050618000	FLAT HEAD SCREW M6X18		1	*			
016-1	005061800N	FLAT HEAD SCREW M6X18	O	1				
017	3705401000	CLUTCH GUIDE		1	*			
017-1	370540100N	CLUTCH GUIDE	O	1	*			
017-2	XNR0000460	CLUTCH GUIDE	O	1				
018	3050770000	CLUTCH SHOE WITH SPRING		1	*			
018-1	305077000N	CLUTCH SHOE WITH SPRING	O	1				

Please order the parts with part number.

Print Date 25/10/2023

Model No.HTR4900 ENGINE HEDGE TRIMMER

Item	Parts No.	Description	I/C	Qty	New/Old	Opt. 1	Opt. 2	Note
019	3050404110	CLUTCH PLATE		1	*			
019-1	305040411N	CLUTCH PLATE	O	1				
020	0050412000	FLAT HEAD SCREW M4X12		2	*			
020-1	005041200N	FLAT HEAD SCREW M4X12	O	2				
021	0020512000	SCREW M5X12		4	*			
021-1	002051200N	SCREW M5X12	O	4	*			
021-2	XNR0000002	SCREW M5X12	O	4				
022	3033501000	ENGINE BASE		1	*			
022-1	303350100N	ENGINE BASE	O	1				
023	0998326000	STOP SWITCH		1	*			
023-1	099832600N	STOP SWITCH	O	1	*			
023-2	XNR0000136	STOP SWITCH	O	1				
024	3033413000	TAPPING SCREW 4.5X16		5	*			
024-1	303341300N	TAPPING SCREW 4.5X16	O	5				
025	3033402210	REAR HANDLE(B)		1	*			
025-1	303340221N	REAR HANDLE(B)	O	1				
026	0998610000	THROTTLE WIRE		1	*			
026-1	099861000N	THROTTLE WIRE	O	1				
027	3033403100	THROTTLE LEVER		1	*			
027-1	3033403200	THROTTLE LEVER	X	1	*			
027-2	303340320N	THROTTLE LEVER	O	1				
028	3033405000	THROTTLE LEVER SPRING		1	*			
028-1	303340500N	THROTTLE LEVER SPRING	O	1				
029	3033406000	LOCK LEVER		1	*			
029-1	303340600N	LOCK LEVER	O	1				
030	3033407000	LOCK LEVER SPRING		1	*			
030-1	303340700N	LOCK LEVER SPRING	O	1				
031	3033401210	REAR HANDLE(A)		1	*			
031-1	303340121N	REAR HANDLE(A)	O	1	*			
031-2	XNR0000400	REAR HANDLE(A)	O	1	*			
031-3	XNR0000505	REAR HANDLE(A)	O	1				
032	3033409000	LOCK PIN SPRING		1	*			
032-1	303340900N	LOCK PIN SPRING	O	1				
033	3033408110	LOCK PIN		1	*			
033-1	303340811N	LOCK PIN	O	1				
034	3033413000	TAPPING SCREW 4.5X16		1	*			
034-1	303341300N	TAPPING SCREW 4.5X16	O	1				
035	3033412000	THROTTLE WIRE HOLDER		1	*			
035-1	303341200N	HOLDER,THROTTLE WIRE	O	1				
036	3033410210	REAR HANDLE HOLDER		1	*			
036-1	3712410000	REAR HANDLE HOLDER	S	1	*			
036-2	371241000N	REAR HANDLE HOLDER	O	1				
037	3033411000	BUSH		2	*			
038	0650618000	TORX BOLT M6X18		2	*			
038-1	065061800N	TORX SCREW M6X18	O	2	*			

Please order the parts with part number.

Print Date 25/10/2023

Model No.HTR4900 ENGINE HEDGE TRIMMER

Item	Parts No.	Description	I/C	Qty	New/Old	Opt. 1	Opt. 2	Note
038-2	XNR0000113	TORX SCREW M6X18	O	2				
039	3035101000	CASE		1	*			
039-1	303510100N	CASE	O	1				
040	0650525000	TORX SCREW M5X25		2	*			
040-1	065052500N	TORX SCREW M5X25	O	2				
041	0650515000	TORX SCREW M5X15		1	*			
041-1	065051500N	TORX SCREW M5X15	O	1				
042	3035107000	CRANK SHAFT		1	*			
042-1	303510700N	CRANK SHAFT	O	1				
043	3035111000	CRANK PLATE		1	*			
043-1	303511100N	CRANK PLATE	O	1				
044	3035220000	CUTTER BLADE		1	*			
044-1	303522000N	CUTTER BLADE	O	1				
045	3035108000	CRANK GEAR		1	*			
045-1	303510800N	CRANK GEAR	O	1				
046	3035220000	CUTTER BLADE		1	*			
046-1	303522000N	CUTTER BLADE	O	1				
047	3035130000	GASKET		1	*			
047-1	303513000N	GASKET	O	1				
048	3035102000	CASE CAVER		1	*			
048-1	303510200N	CASE COVER	O	1				
049	0998615000	CLAMP		1	*			
049-1	099861500N	CLAMP	O	1				
050	0650412000	TORX BOLT 4X12		6	*			
050-1	065041200N	TORX BOLT M4X12	O	6				
051	0320400000	SPRING WASHER		6	*			
051-1	032040000N	SPRING WASHER 4	O	6				
052	0650520000	TORX SCREW M5X20		4	*			
052-1	065052000N	TORX SCREW M5X20	O	4	*			
052-2	XNR0000098	TORX SCREW M5X20	O	4				
053	3060204000	BLADE BOLT WASHER		4	*			
053-1	306020400N	BLADE BOLT WASHER	O	4				
054	3035209000	GUIDE BLOCK		4	*			
054-1	303520900N	GUIDE BLOCK	O	4				
055	3035112000	GREASE PLATE		1	*			
055-1	303511200N	PLATE	O	1				
056	3035104000	GASKET		1	*			
056-1	303510400N	GASKET	O	1				
057	0680535000	BOLT M5X35		1	*			
057-1	068053500N	BT M5X35	O	1				
058	0680535000	BOLT M5X35		1	*			
058-1	068053500N	BT M5X35	O	1				
059	0300514000	FLANGE NUT M5		1	*			
059-1	030051400N	NUT,FLANGE M5	O	1				
060	0300514000	FLANGE NUT M5		1	*			

Please order the parts with part number.

Print Date 25/10/2023

Model No.HTR4900 ENGINE HEDGE TRIMMER

Item	Parts No.	Description	I/C	Qty	New/Old	Opt. 1	Opt. 2	Note
060-1	030051400N	NUT,FLANGE M5	O	1				
061	0290604000	GREASE NIPPLE		1	*			
061-1	029060400N	NIPPLE	O	1	*			
061-2	XNR0000022	NIPPLE	O	1				
062	0300814000	FLANGE NUT M8		1	*			
062-1	030081400N	NUT,FLANGE M8	O	1				
063	3035601000	CUTTER BLADE COVER		1	*			
063-1	303560100N	CUTTER BLADE COVER	O	1				
064	0300511000	NYLON NUT M5		4	*			
064-1	030051100N	NYLON NUT M5	O	4				
065	3033290000	PROTECTOR		1	*			
065-1	303329000N	PROTECTOR	O	1				
066	3035201000	CUTTER GUIDE		1	*			
066-1	303520100N	CUTTER GUIDE	O	1				
067	0140059550	SCREW M5X14		1	*			
067-1	265A10-2	PAN HEAD SCREW M5X14	O	1				
068	5193500201	MUFFLER COVER		1				
069	0119059600	SOCKET HEAD BOLT M5X45		2	*			
069-1	266697-7	SOCKET HEAD BOLT M5X45	O	2				
070	5193020000	EXHAUST MUFFLER		1				
071	5193500302	MUFFLER INSULATOR		1				
072	5197003021	COIL		1				
073	0043704200	SCREW ASS'Y M4X20		2				
074	5257018001	WIRE COMPLETE		1	*			
074-1	638665-4	LEAD UNIT	O	1				
075	5191500301	CYLINDER GASKET		1	*			
075-1	442173-7	CYLINDER GASKET	O	1				
076	5212500500	PISTON RING		1	*			
076-1	257320-5	PISTON RING	O	1				
077	5192501701	PISTON		1	*			
077-1	318831-6	PISTON	O	1				
078	5192500500	PISTON PIN		1	*			
078-1	268277-5	PISTON PIN	O	1				
079	0565089970	CLIP		1	*			
079-1	233976-8	CLIP	O	1				
080	5192003003	CRANKSHAFT COMPL		1	*			
080-1	5192003004	CRANKSHAFT COMPLETE	O	1				
081	0565089970	CLIP		1	*			
081-1	233976-8	CLIP	O	1				
082	0140059400	SCREW ASSEMBLY		2	*			
082-1	265A09-7	PAN HEAD SCREW M5X20	O	2				
083	5213001000	INSULATOR COMPLETE		1				
084	5233503902	INSULATOR GASKET		1	*			
084-1	424448-6	INSULATOR GASKET	O	1				
085	0650149640	SPARK PLUG		1				

Please order the parts with part number.

Print Date 25/10/2023

Model No.HTR4900 ENGINE HEDGE TRIMMER

Item	Parts No.	Description	I/C	Qty	New/Old	Opt. 1	Opt. 2	Note
086	5191500901	CYLINDER		1	*			
086-1	318785-7	CYLINDER	O	1				
087	0119059730	SOCKET HEAD BOLT M5X20		2	*			
087-1	266814-9	HEX SOCKET HEAD BOLT M5X20	O	2				
088	5503503001	SPACER		1				
089	5257500300	GROMMET		1	*			
089-1	424313-9	GROMMET	O	1				
090	0654009931	PLUG CAP SPRING		1	*			
090-1	324891-8	PLUG CAP SPRING	O	1				
091	0655009870	PLUG CAP		1	*			
091-1	424337-5	PLUG CAP	O	1				
092	5197500002	PLUG CAP COVER		1				
093	0140059490	SCREW		1				
094	5195500701	CYLINDER COVER		1				
095	6279505700	TRADE MARK LABEL "MAKITA"		1				
096	5195003003	REWIND STARTER		1				
D10		INC. 97-105						
097	5195500000	PULLEY		1	*			
097-1	168483-1	PULLEY	O	1				
098	5195002060	SET SCREW		1	*			
098-1	266585-8	TAPPING SCREW 5X12	O	1				
099	5195002100	SWING ARM		1	*			
099-1	325923-4	SWING ARM	O	1				
100	5195002110	COLLAR		1	*			
100-1	451938-6	COLLAR	O	1				
101	5195002030	REEL		1	*			
101-1	452972-9	REEL	O	1				
102	5255016020	STARTER ROPE		1	*			
102-1	444024-0	STARTER ROPE	O	1				
103	5195002050	SPIRAL SPRING		1	*			
103-1	234220-6	SPIRAL SPRING	O	1				
104	5255001040	DAMPER		1	*			
104-1	424359-5	DAMPER	O	1				
105	5225004020	HANDLE		1	*			
105-1	424319-7	STARTER KNOB	O	1				
106	6019508400	MODEL LABEL		1				
107	0140049760	SCREW ASSEMBLY		4				
108	0150059780	TAPPING SCREW M5X20		3	*			
108-1	266713-5	TAPPING SCREW 5X20	O	3				
109	5195500800	BLOWER HOUSING		1				
110	0173089990	LOCK NUT		1	*			
110-1	931403-6	HEX. NUT M8	O	1				
111	0031008000	WASHER		1	*			
111-1	941202-8	FLAT WASHER 8	O	1				

Please order the parts with part number.

Print Date 25/10/2023

Model No.HTR4900 ENGINE HEDGE TRIMMER

Item	Parts No.	Description	I/C	Qty	New/Old	Opt. 1	Opt. 2	Note
112	5197003014	FLYWHEEL		1				
113	5191006000	CRANK CASE ASS'Y		1	*			
D10		INC. 114-119			*			
113-1	126755-0	CRANK CASE ASSEMBLY	O	1				
D10		INC. 114-119						
114	0440109980	OIL SEAL		1	*			
114-1	213638-4	OIL SEAL	O	1				
115	0140059520	SCREW M5X25		3	*			
115-1	266701-2	PAN HEAD SCREW M5X25	O	3	*			
115-2	922241-7	HEX. SOCKET HEAD BOLT M5X25	O	3				
116	0600109980	BALL BEARING 6000		1	*			
116-1	210086-8	BALL BEARING 6000	O	1				
117	0600109980	BALL BEARING 6000		1	*			
117-1	210086-8	BALL BEARING 6000	O	1				
118	5191500400	CRANKCASE GASKET		1	*			
118-1	442174-5	CRANK CASE GASKET	O	1				
119	0440109980	OIL SEAL		1	*			
119-1	213638-4	OIL SEAL	O	1				
120	5196500302	DAMPER		1	*			
120-1	424104-8	DAMPER	O	1				
121	5196500201	FUEL TANK PLATE		1				
122	0043605100	SCREW ASSEMBLY		1	*			
122-1	911208-0	PAN HEAD SCREW M5X10	O	1				
123	0851149950	TUBE COMPLETE		1				
124	0561059990	HOSE CLAMP		1	*			
124-1	345920-4	HOSE CLAMP	O	1				
125	5236503900	FILTER		1	*			
125-1	163447-0	FUEL FILTER	O	1	*			
125-2	163447-0	FUEL FILTER	O	1				
126	5196011000	FUEL TANK COMPLETE		1				
127	5256059000	FUEL TANK CAP COMPLETE		1	*			
D10		INC. 128,129			*			
127-1	168668-9	FUEL TANK CAP COMPLETE	O	1				
D10		INC. 128,129						
128	5256067000	STRAP		1	*			
128-1	140436-2	STRAP COMPLETE	O	1				
129	5256058000	FUEL TANK CAP		1	*			
129-1	452920-8	FUEL TANK CAP	O	1				
130	0150059830	TAPPING SCREW		2	*			
130-1	266714-3	TAPPING SCREW 5X16	O	2				
131	5103502801	SPACER GASKET		1	*			
131-1	442177-9	GASKET AIR CLEANER	O	1				
132	5316020020	CABLE ADJUST SCREW		1	*			
132-1	326084-3	CABLE ADJUST SCREW M6X13	O	1				

Please order the parts with part number.

Print Date 25/10/2023

Model No.HTR4900 ENGINE HEDGE TRIMMER

Item	Parts No.	Description	I/C	Qty	New/Old	Opt. 1	Opt. 2	Note
133	0022706000	NUT M6		1				
134	5256501900	CABLE BRACKET		1				
135	5103502801	SPACER GASKET		1	*			
135-1	442177-9	GASKET AIR CLEANER	O	1				
136	5196038000	CARBURETOR		1				
D10		INC. 137-152						
137	5316005120	RING		1	*			
137-1	257964-1	STOP RING E-3	O	1				
138	5236018040	SWIVEL		1	*			
138-1	325922-6	SWIVEL	O	1				
139	5206008030	PAN HEAD SCREW		2	*			
139-1	266581-6	PAN HEAD SCREW M3X8 WITH W	O	2	*			
139-2	WJ00096364	SCREW M3X8 WITH WASHER	O	2				
140	5196002010	THROTTLE VALVE ASS'Y		1				
141	5246001010	O RING		1	*			
141-1	213538-8	O RING 2	O	1				
142	5256024020	JET		1				
143	5246001030	PUMP GASKET		1	*			
143-1	442172-9	PUMP GASKET	O	1				
144	5246001040	PUMP DIAPHRAGM		1	*			
144-1	168575-6	PUMP DIAPHRAGM	O	1	*			
144-2	WJ00009599	PUMP DIAPHRAGM	O	1				
145	5016004010	INLET SCREEN		1	*			
145-1	352010-6	INLET SCREEN	O	1	*			
145-2	WJ00014070	INLET SCREEN	O	1				
146	5236046130	PUMP BODY ASS'Y		1	*			
146-1	140989-1	PUMP BODY ASSEMBLY	O	1				
147	5236046040	METERING DIAPHRAGM GASKET		1	*			
147-1	442154-1	METERING DIAPHRAGM GASKET	O	1				
148	5316005250	METERING DIAPHRAGM ASS'Y		1	*			
148-1	168767-7	METERING DIAPHRAGM	O	1				
149	5236046060	AIR PURGE BODY ASS'Y		1	*			
149-1	140988-3	AIR PURGE BODY ASSEMBLY	O	1				
150	5246001150	PRIMER PUMP		1	*			
150-1	424314-7	PRIMER PUMP	O	1				
151	5236046050	PRIMER PUMP COVER		1	*			
151-1	346270-0	PRIMER PUMP COVER	O	1				
152	5236046010	PUMP COVER SCREW		4	*			
152-1	266582-4	TAPPING SCREW 3X24	O	4				
153	5236061000	O RING		1				
154	5253003020	AIR CLEANER HOUSING COMPLETE		1				
155	5203004010	AIR FILTER		1				
156	5253055010	AIR CLEANER COVER		1				
157	0043305600	SCREW ASS'Y M5X60(W/W)		2				

Please order the parts with part number.

Print Date 25/10/2023