

Model No.HTR5600 ENGINE HEDGE TRIMMER

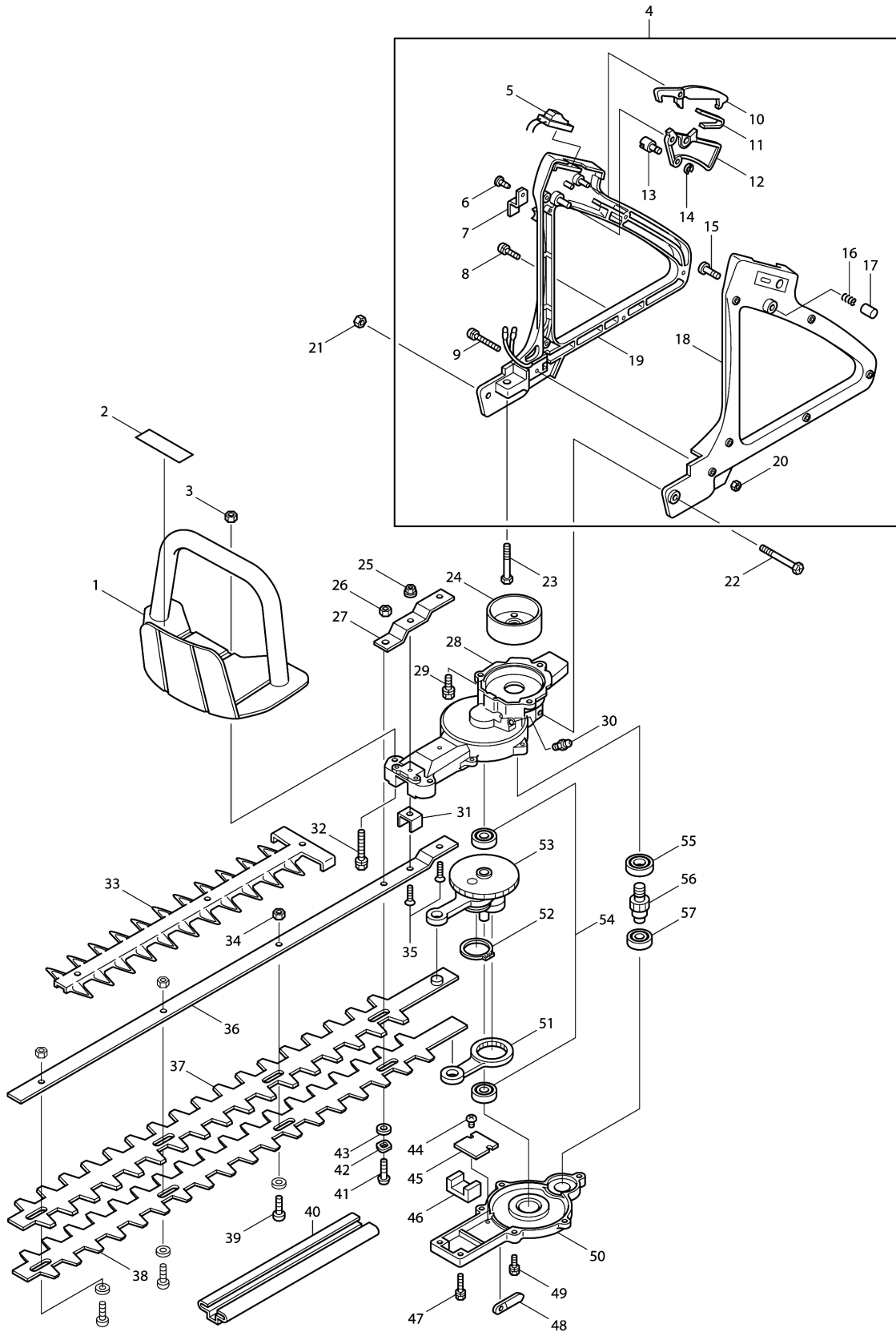

Model No.HTR5600 ENGINE HEDGE TRIMMER

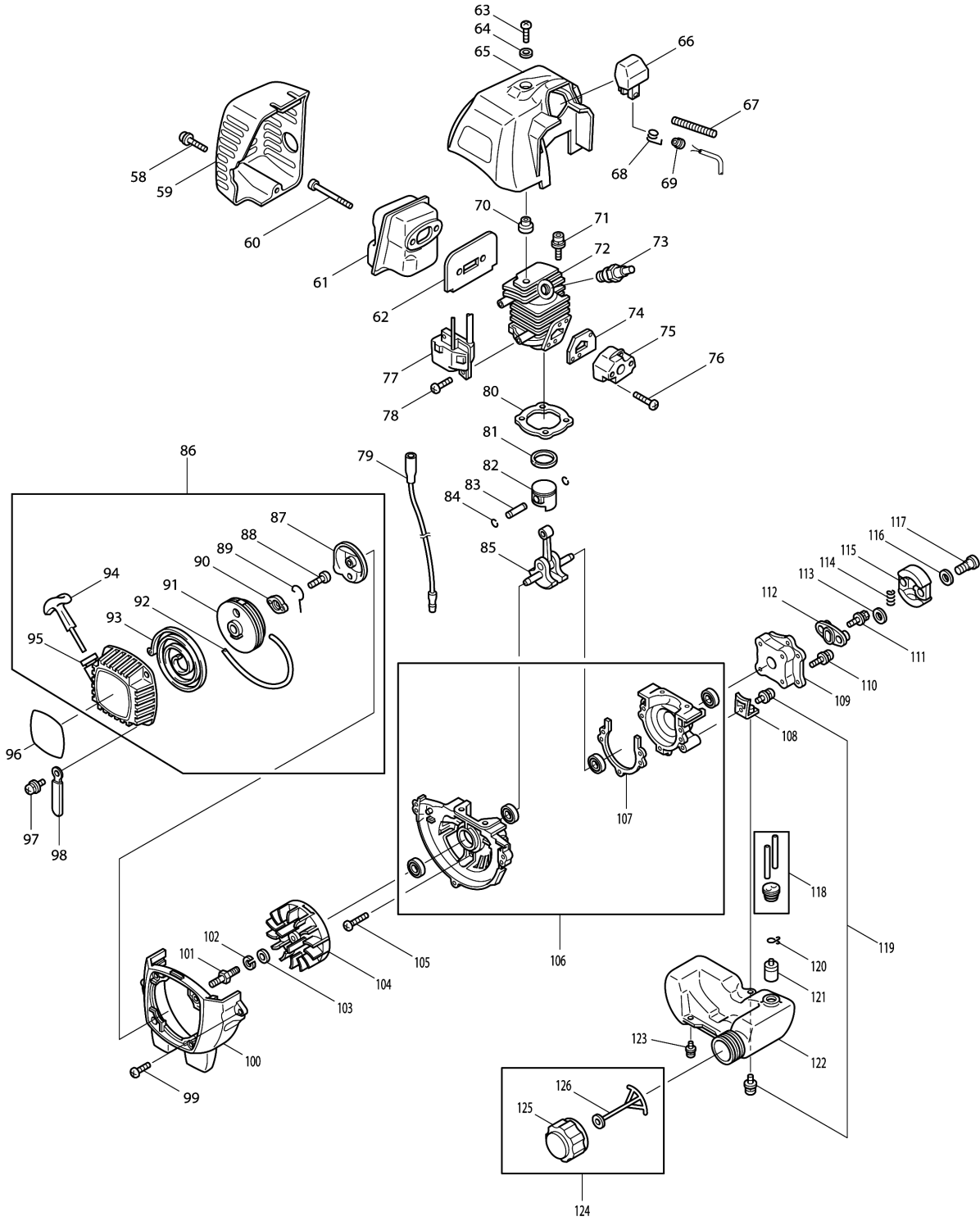

Model No.HTR5600 ENGINE HEDGE TRIMMER

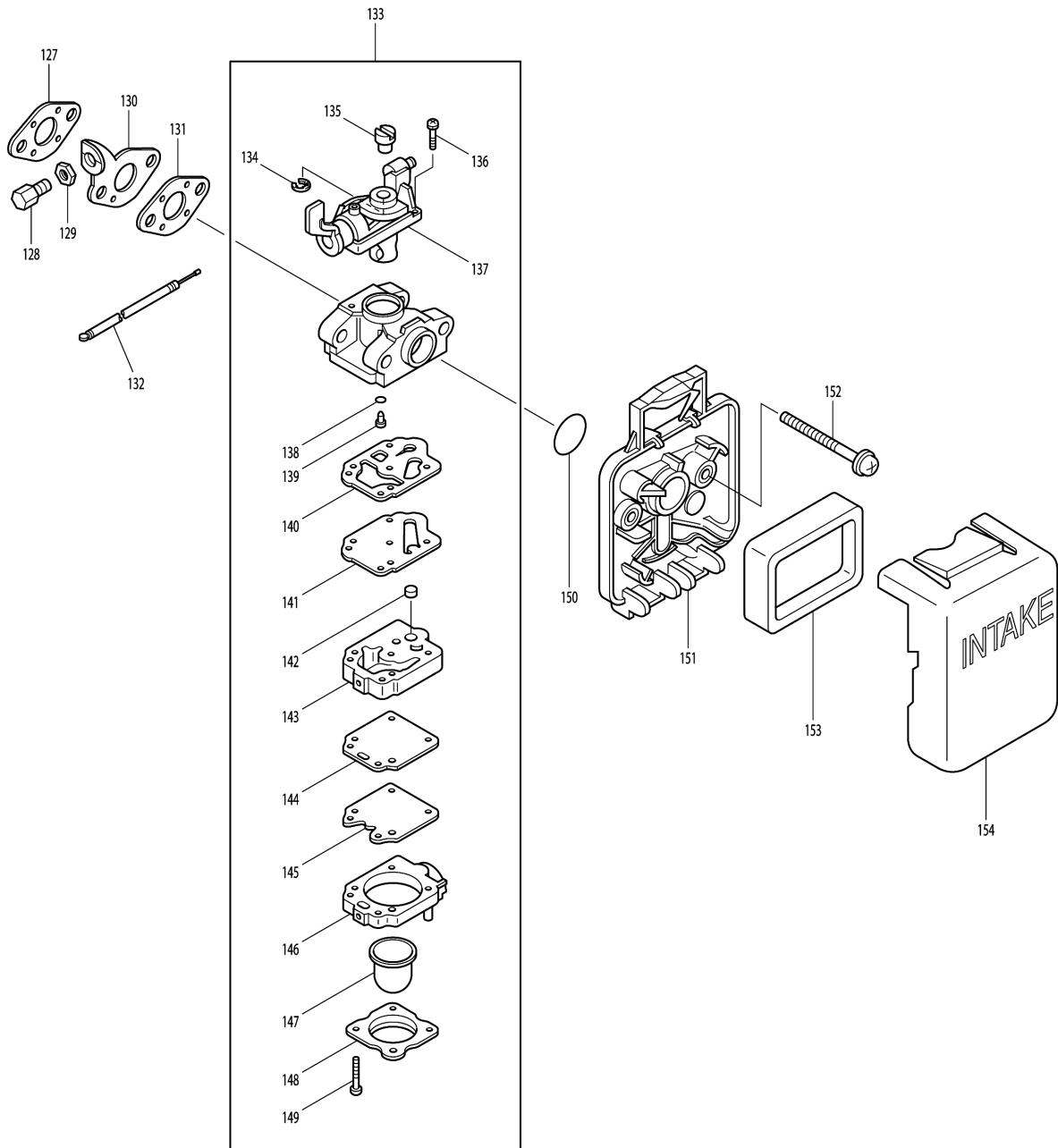

Model No.HTR5600 ENGINE HEDGE TRIMMER

Item	Parts No.	Description	I/C	Qty	New/Old	Opt. 1	Opt. 2	Note
001	1181150000	LEVER		1	*			
001-1	1181550000	FRONT HANDLE	X	1				
002	0736359980	CAUTION LABEL		1				
003	0151060000	NUT M6		2	*			
003-1	151060000K	HEX. NUT 2 M6	O	2				
004	1180110000	REAR HANDLE ASS'Y		1	*			
D10		INC. 5-20			*			
004-1	126493-4	CONTROL LEVER ASSY	O	1				
D10		INC. 5-20						
005	0005044004	SWITCH		1	*			
005-1	005044004A	SLIDE SWITCH	O	1				
006	0112040100	SCREW M4X10		1	*			
006-1	112040100K	TAPPING SCREW M4X10	O	1				
007	1181210000	CABLE HOLDER		1				
008	0017040160	SCREW M4X16(W,SW)		5	*			
008-1	017040160K	PAN HEAD SCREW M4X16	O	5				
009	0017040300	SCREW M4X30(W,SW)		1	*			
009-1	017040300K	PAN HEAD SCREW M4X30	O	1				
010	1181510000	STOPPER		1	*			
010-1	XOC0000033	STOPPER	<	1				
011	0003010004	SPRING		1	*			
011-1	1181620000	LEAF SPRING	<	1				
012	1181150000	LEVER		1	*			
012-1	XOC0000032	LEVER	<	1				
013	1181110000	WIRE END		1				
014	0280002500	SNAP RING		1	*			
014-1	280002500K	RETAINING RING ETW 2.5	O	1				
015	1181120000	LEVER PIN		1	*			
016	1181140000	SPRING		1	*			
017	1181130000	PIN CAP		1	*			
018	1181500000	REAR HANDLE (L)		1				
019	1181490000	REAR HANDLE (R)		1				
020	0015004000	NUT M4		6	*			
020-1	150040000K	HEX. NUT M4	O	6				
021	0151060000	NUT M6		1	*			
021-1	151060000K	HEX. NUT 2 M6	O	1				
022	0055060500	BOLT M6X50 (W,SW,PW)		1	*			
022-1	266881-4	+HEX BOLT M6X50 WITH.WR	O	1				
023	0055060400	BOLT M6X40		1	*			
023-1	055060400K	(+)HEX. BOLT M6X40	O	1				
024	1361410000	DRUM COMPLETE		1				
025	0162050000	FLANGE NUT M5		1	*			
025-1	162050000K	FLANGE NUT M5	O	1				
026	0162050000	FLANGE NUT M5		1	*			
026-1	162050000K	FLANGE NUT M5	O	1				

Please order the parts with part number.

Print Date 25/10/2023

Model No.HTR5600 ENGINE HEDGE TRIMMER

Item	Parts No.	Description	I/C	Qty	New/Old	Opt. 1	Opt. 2	Note
027	0325102004	PLATE		1	*			
027-1	3251020040	REINFORCING PLATE	O	1				
028	0325100002	UPPER CASE		1				
029	0054060150	BOLT M6X15		2	*			
029-1	054060150K	(+)HEX. BOLT M6X15	O	2				
030	0055000100	GREASE NIPPLE M6		1	*			
030-1	055000100R	GREASING NIPPLE	O	1				
031	0325103004	PLATE		1	*			
031-1	3251030040	SLIGHTLY STOPPER	O	1				
032	0054060350	BOLT M6X35		2	*			
032-1	054060350K	BOLT M6X35 (W/SW)	O	2				
033	0287110002	BLADE GUARD		1	*			
033-1	287110002A	BLADE GUARD (W)	O	1	*			
033-2	XOC0000030	BLADE GUARD	<	1				
034	0164060000	U-NUT M6		4	*			
034-1	164060000K	HEX. U-NUT M6	O	4				
035	0011050205	SCREW M5X20		2	*			
035-1	011050205K	SCREW M5X20	O	2				
036	1181260000	BLADE SUPPORT BAR		1				
037	6018505400	UPPER BLADE		1				
038	6018505500	LOWER BLADE		1				
039	0040002009	SCREW L=19		3	*			
039-1	040002009A	BLADE SLIDE SCREW L19	O	3				
040	0028002039	BLADE COVER		1	*			
040-1	028002039A	BLADE COVER	O	1				
041	0040003009	SCREW M6X22		1	*			
041-1	040003009A	SCREW M6X22	O	1				
042	0229060000	WAVE WASHER		1	*			
042-1	229060000K	WAVE WASHER	O	1				
043	0082500000	BLADE SLIDING WASHER		4				
044	0010030050	SCREW M3X5		2	*			
044-1	010030050K	(+)PAN HEAD SCREW M3X5	O	2				
045	0301100000	ROD SLIDING PLATE		1				
046	0325104004	FELT		1	*			
046-1	3251040040	FELT	O	1				
047	0054050160	BOLT M5X16(W,SW)		2	*			
047-1	054050160K	(+)HEX. BOLT M5X16	O	2				
048	0566079970	CLAMP		1				
049	0054050160	BOLT M5X16(W,SW)		5	*			
049-1	054050160K	(+)HEX. BOLT M5X16	O	5				
050	0325101002	LOWER CASE		1	*			
050-1	3251010020	CASE (LOWER)	O	1				
051	1181000000	ROD		1	*			
051-1	TE1A044000	ROD	O	1	*			
051-2	1A044000TE	ROD	O	1	*			

Please order the parts with part number.

Print Date 25/10/2023

Model No.HTR5600 ENGINE HEDGE TRIMMER

Item	Parts No.	Description	I/C	Qty	New/Old	Opt. 1	Opt. 2	Note
051-3	XOC0000018	ROD	O	1				
052	0283026000	SNAP RING		1	*			
052-1	283026000K	RETAINING RING STW-26	O	1				
053	1360030000	GEAR CRANK ASS'Y		1				
054	0353006080	BALL BEARING ZZ 608		2	*			
054-1	353006080K	BEARING 608ZZ	O	2				
055	0354060010	BALL BEARING UU 6001		1	*			
055-1	354060010K	BALL BEARING 6001 2RS	O	1				
056	1361420000	PINION GEAR		1				
057	0353006080	BALL BEARING ZZ 608		1	*			
057-1	353006080K	BEARING 608ZZ	O	1				
058	0140059290	SCREW ASSY		1				
059	5253500500	MUFFLER COVER		1				
060	0119059550	SOCKET HEAD BOLT		2	*			
060-1	266754-1	SOCKET HEAD BOLT	O	2				
061	5253071000	EXHAUST MUFFLER		1				
062	5253500102	MUFFLER GASKET		1				
063	0140059490	SCREW		1				
064	0200070010	WASHER		1				
065	5255500301	CYLINDER COVER (MAKITA COLOR)		1				
066	5237503301	PLUG CAP		1				
067	0851049950	TUBE		1				
068	0654009931	PLUG CAP SPRING		1	*			
068-1	324891-8	PLUG CAP SPRING	O	1				
069	5257500300	GROMMET		1	*			
069-1	424313-9	GROMMET	O	1				
070	5503503001	SPACER		1				
071	0119059730	SOCKET HEAD BOLT M5X20		2	*			
071-1	266814-9	HEX SOCKET HEAD BOLT M5X20	O	2				
072	5251500201	CYLINDER		1	*			
072-1	5231501804	CYLINDER	O	1	*			
072-2	318762-9	CYLINDER	O	1				
073	0650149721	SPARK PLUG		1	*			
073-1	168662-1	SPARK PLUG(BMR7A)	O	1				
074	5253500200	INSULATOR GASKET		1				
075	5233014000	INSULATOR COMPL.		1	*			
075-1	141056-5	INSULATOR COMPLETE	O	1				
076	0140059500	SCREW M5X25		2	*			
076-1	266700-4	PAN HEAD SCREW M5X25	O	2				
077	5257001021	COIL		1				
078	0140049920	SCREW ASS'Y M4X20		2				
079	5607005000	WIRE COMPLETE (2)		1				
080	5231502304	CYLINDER GASKET		1	*			
080-1	442171-1	CYLINDER GASKET	O	1				

Please order the parts with part number.

Print Date 25/10/2023

Model No.HTR5600 ENGINE HEDGE TRIMMER

Item	Parts No.	Description	I/C	Qty	New/Old	Opt. 1	Opt. 2	Note
081	5242500701	PISTON RING		1	*			
081-1	257979-8	PISTON RING	O	1				
082	5232501902	PISTON		1				
083	5232502600	PISTON PIN		1	*			
083-1	257781-9	PISTON PIN	O	1				
084	0565089970	CLIP		2	*			
084-1	233976-8	CLIP	O	2				
085	5252002001	CRANKSHAFT COMPLETE		1	*			
085-1	5252002002	CRANKSHAFT COMPLETE	O	1	*			
085-2	144403-9	CRANK SHAFT COMPLETE	S	1				
086	5255052000	REWIND STARTER		1				
D10		INC. 87-95						
087	5255505900	PULLY		1				
088	5195002060	SET SCREW		1	*			
088-1	266585-8	TAPPING SCREW 5X12	O	1				
089	5195002100	SWING ARM		1	*			
089-1	325923-4	SWING ARM	O	1				
090	5195002110	COLLAR		1	*			
090-1	451938-6	COLLAR	O	1				
091	5195002030	REEL		1	*			
091-1	452972-9	REEL	O	1				
092	5255016020	STARTER ROPE		1	*			
092-1	444024-0	STARTER ROPE	O	1				
093	5195002050	SPIRAL SPRING		1	*			
093-1	234220-6	SPIRAL SPRING	O	1				
094	5225004020	HANDLE		1	*			
094-1	424319-7	STARTER KNOB	O	1				
095	5255001040	DAMPER		1	*			
095-1	424359-5	DAMPER	O	1				
096	6019509000	MODEL LABEL		1	*			
096-1	809M36-2	HTR5600 MODEL NO. LABEL	<	1				
097	0140049760	SCREW ASSEMBLY		4				
098	0566059980	CLAMP		1	*			
098-1	345963-6	CLAMP	O	1				
099	0140059350	SCREW ASS'Y M5X18(W,SW)		3	*			
099-1	266699-3	PAN HEAD SCREW M5X18	O	3				
100	5255505700	BLOWER HOUSING		1				
101	5257501400	BOLT		1				
102	0032006000	SPRING WASHER		1				
103	0031206000	WASHER		1	*			
103-1	253429-1	FLAT WASHER 7	O	1				
104	5257041010	FLYWHEEL		1				
105	0140059520	SCREW M5X25		3	*			
105-1	266701-2	PAN HEAD SCREW M5X25	O	3	*			
105-2	922241-7	HEX. SOCKET HEAD BOLT M5X25	O	3				

Please order the parts with part number.

Print Date 25/10/2023

Model No.HTR5600 ENGINE HEDGE TRIMMER

Item	Parts No.	Description	I/C	Qty	New/Old	Opt. 1	Opt. 2	Note
106	5251003000	CRANKCASE COMPLETE		1				
D10		INC. 107						
107	5231502202	CRANKCASE GASKET		1	*			
107-1	424447-8	CRANK CASE GASKET	O	1				
108	5256002000	TANK PLATE COMPLETE		1				
109	1181240000	SPACER		1	*			
109-1	318892-6	SPACER	O	1				
110	0140059350	SCREW ASS'Y M5X18(W,SW)		4	*			
110-1	266699-3	PAN HEAD SCREW M5X18	O	4				
111	6202006000	BOLT ASS'Y		1	*			
111-1	5235504700	BOLT ASS'Y	O	1	*			
111-2	266703-8	HEX. HEAD BOLT M6X14	O	1				
112	6202500000	HOLDER		1				
113	6202500600	WASHER		2	*			
113-1	267429-5	FLAT WASHER 6	O	2				
114	5238500500	CLUTCH SPRING		1				
115	6252500801	CLUTCH SHOE		2				
116	0200089911	WASHER M8		2	*			
116-1	267817-6	WASHER 8	O	2				
117	6252500400	CLUTCH BOLT		2	*			
117-1	266457-7	SHOULDER HEX. BOLT M6X25	O	2	*			
117-2	266864-4	SHOULDER HEX. BOLT M6X25	O	2				
118	5256012001	TUBE ASS'Y		1				
119	0140059290	SCREW ASSY		2				
120	0561059990	HOSE CLAMP		1	*			
120-1	345920-4	HOSE CLAMP	O	1				
121	5236503900	FILTER		1	*			
121-1	163447-0	FUEL FILTER	O	1	*			
121-2	163447-0	FUEL FILTER	O	1				
122	5256025000	FUEL TANK COMPLETE		1				
123	0150059800	TAPPING SCREW M5X18		2				
124	5256059000	FUEL TANK CAP COMPLETE		1	*			
D10		INC. 125,126			*			
124-1	168668-9	FUEL TANK CAP COMPLETE	O	1				
D10		INC. 125,126						
125	5256058000	FUEL TANK CAP		1	*			
125-1	452920-8	FUEL TANK CAP	O	1				
126	5256067000	STRAP		1	*			
126-1	140436-2	STRAP COMPLETE	O	1				
127	5103502801	SPACER GASKET		1	*			
127-1	442177-9	GASKET AIR CLEANER	O	1				
128	5316020020	CABLE ADJUST SCREW		1	*			
128-1	326084-3	CABLE ADJUST SCREW M6X13	O	1				
129	0022706000	NUT M6		1				
130	5256501900	CABLE BRACKET		1				

Please order the parts with part number.

Print Date 25/10/2023

Model No.HTR5600 ENGINE HEDGE TRIMMER

Item	Parts No.	Description	I/C	Qty	New/Old	Opt. 1	Opt. 2	Note
131	5103502801	SPACER GASKET		1	*			
131-1	442177-9	GASKET AIR CLEANER	O	1				
132	0630029830	CONTROL CABLE		1				
133	5256085000	CARBURETOR		1				
D10		INC. 134-149						
134	5316005120	RING		1	*			
134-1	257964-1	STOP RING E-3	O	1				
135	5236018040	SWIVEL		1	*			
135-1	325922-6	SWIVEL	O	1				
136	5206008030	PAN HEAD SCREW		2	*			
136-1	266581-6	PAN HEAD SCREW M3X8 WITH W	O	2	*			
136-2	WJ00096364	SCREW M3X8 WITH WASHER	O	2				
137	5196002010	THROTTLE VALVE ASS'Y		1				
138	5246001010	O RING		1	*			
138-1	213538-8	O RING 2	O	1				
139	5026004010	JET		1	*			
139-1	326085-1	JET	O	1				
140	5246001030	PUMP GASKET		1	*			
140-1	442172-9	PUMP GASKET	O	1				
141	5246001040	PUMP DIAPHRAGM		1	*			
141-1	168575-6	PUMP DIAPHRAGM	O	1	*			
141-2	WJ00009599	PUMP DIAPHRAGM	O	1				
142	5016004010	INLET SCREEN		1	*			
142-1	352010-6	INLET SCREEN	O	1	*			
142-2	WJ00014070	INLET SCREEN	O	1				
143	5236046130	PUMP BODY ASS'Y		1	*			
143-1	140989-1	PUMP BODY ASSEMBLY	O	1				
144	5236046040	METERING DIAPHRAGM GASKET		1	*			
144-1	442154-1	METERING DIAPHRAGM GASKET	O	1				
145	5316005250	METERING DIAPHRAGM ASS'Y		1	*			
145-1	168767-7	METERING DIAPHRAGM	O	1				
146	5236046060	AIR PURGE BODY ASS'Y		1	*			
146-1	140988-3	AIR PURGE BODY ASSEMBLY	O	1				
147	5246001150	PRIMER PUMP		1	*			
147-1	424314-7	PRIMER PUMP	O	1				
148	5236046050	PRIMER PUMP COVER		1	*			
148-1	346270-0	PRIMER PUMP COVER	O	1				
149	5236046010	PUMP COVER SCREW		4	*			
149-1	266582-4	TAPPING SCREW 3X24	O	4				
150	5236061000	O RING		1				
151	5253003020	AIR CLEANER HOUSING COMPLETE		1				
152	0043305650	SCREW ASS'Y		2	*			
152-1	265667-3	PAN HEAD SCREW M5X65 WITH R	O	2				

Please order the parts with part number.

Print Date 25/10/2023

Model No.HTR5600 ENGINE HEDGE TRIMMER

Item	Parts No.	Description	I/C	Qty	New/Old	Opt. 1	Opt. 2	Note
153	5203004010	AIR FILTER		1				
154	5253020010	AIR CLEANER COVER		1				
157	0610089990	NEEDLE ROLLER BEARING	S	1				
A01	5019001000	TOOL		1				
E01	1181600000	BUSH		1				

Please order the parts with part number.

Print Date 25/10/2023