

Model No. JV102D CORDLESS JIG SAW

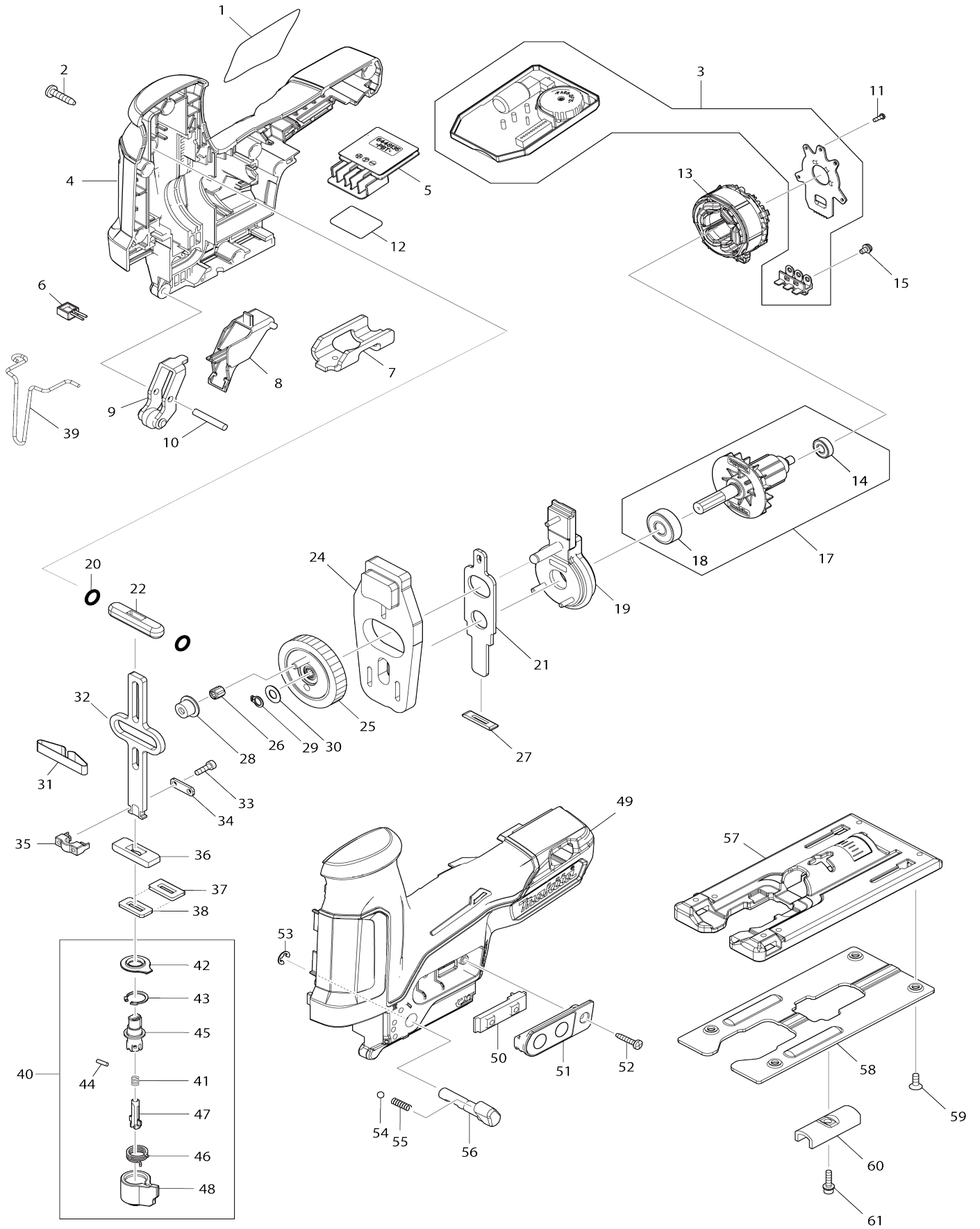

Model No. JV102D CORDLESS JIG SAW

Item No.	Parts No.	Description	Interchangeability	Q'ty	New/Old	Note1	Note2
001	853P44-3	JV102D NAME PLATE		1	*		
001-1	853P43-5	JV102D NAME PLATE	<	1			
002	266326-2	TAPPING SCREW 4X18		9			
003	620710-9	CONTROLLER		1	*		
003-1	620906-2	CONTROLLER	<	1			
004	183H17-7	HOUSING SET		1			
D10		INC. 49					
005	644813-5	TERMINAL		1			
006	620712-5	LED CIRCUIT		1			
007	347251-7	HOLDER		1			
008	457866-3	RETAINER GUIDE		1			
009	144629-3	RETAINER COMPLETE		1			
010	256206-0	PIN 4		1			
011	266490-9	TAPPING SCREW PT 2X6		3			
012	853P50-8	JV102D SERIAL NO. LABEL		1			
013	629281-3	STATOR		1			
014	211157-4	BALL BEARING 695ZZ		1			
015	652069-6	FLAT HEAD SCREW M3X6		3			
017	519452-9	ROTOR ASSY		1	*		
D10		INC. 14,18					
017-1	519452-9	ROTOR ASSY	O	1			
D10		INC. 14,18					
018	210005-4	BALL BEARING 608DDW		1			
019	144820-3	BEARING CASE COMPLETE		1			
020	213038-8	O RING 5		2			
021	347249-4	PUSH PLATE		1			
022	313082-6	SLIDER GUIDE		1			
024	310812-6	BALANCE PLATE		1			
025	144630-8	GEAR COMPLETE		1			
026	212965-6	NEEDLE CAGE 407		1			
027	416703-0	DUST SEAL		1			
028	257804-3	SHOULDER SLEEVE 7		1			
029	961002-0	RETAINING RING S-6		1			
030	253715-0	FLAT WASHER 6		1			
031	232183-0	LEAF SPRING		1			
032	347250-9	SLIDER		1			
033	266177-3	HEX. SOCKET HEAD BOLT M3X10		2			
034	347247-8	PLATE		1			
035	310811-8	BLADE CLAMP		1			
036	313086-8	SLIDER SUPPORT		1			
037	344686-3	SEAL PLATE		1			
038	423307-1	POLYURETHANE SPONGE SEAL		1			
039	323748-0	SAFETY WIRE		1			
040	135941-2	BLADE GUIDE ASS'Y		1			
D10		INC. 41-48					
041	233314-4	COMPRESSION SPRING 4		1			
042	424437-1	DUST COVER		1			

043	962063-3	RETAINING RING R-13		1		
044	256528-8	PIN 2		1		
045	310810-0	BLADE GUIDE		1		
046	233591-8	TORSION SPRING 10		1		
047	310485-5	LOCK PIN		1		
048	452850-3	INSERT HOLDER		1		
049	183H17-7	HOUSING SET		1		
D10		INC. 4				
050	620714-1	SWITCH UNIT		1		
051	144628-5	SWITCH PLATE COMPLETE		1		
052	266130-9	TAPPING SCREW BIND PT 3X16		1		
053	961011-9	STOP RING E-4		1		
054	216008-6	STEEL BALL 4		1		
055	233151-6	COMPRESSION SPRING 4		1		
056	271441-9	LEVER 19		1		
057	319620-2	BASE		1		
058	345441-6	BASE PLATE		1		
059	912107-9	COUNTERSUNK HEAD SCREW M4 X8		4		
060	344685-5	CLAMP PLATE		1		
061	922128-3	HEX. SOCKET HEAD BOLT M4X16		1		
A01	A-85628	JIGSAW BLADE NO.B10		1		
A02	783201-2	HEX. WRENCH 3		1		
A03	457867-1	COVER PLATE		1		
A11	457801-1	DUST NOZZLE		1		
A12	458191-5	DUST COVER		1		
F01	192557-6	ANTI-SPLITTING DEVICE		1		
F03	194367-7	GUIDE RAIL 3000 SET		1		
F04	194368-5	GUIDE RAIL 1400 SET		1		
F05	194925-9	GUIDE RAIL 1900 SET		1		
F06-1	198704-7	GUIDE RAIL ADAPTER SET	O	1		
F10	198968-3	BATTERY BL1016 SET		1		
F11	198969-1	BATTERY BL1016 SET (2PIECES)		1		
F12-1	198970-6	BATTERY BL1021B SET (2PIECES)	O	1		
F13-1	199002-2	BATTERY BL1041B SET (2PIECES)	O	1		
F14	199140-0	GUIDE RAIL 1000 SET		1		
F15	199141-8	GUIDE RAIL 1500 SET		1		
A04	821549-5	CONNECTOR PLASTIC CASE (TYP E1)		1		
C10	453974-8	LATCH		4		
A05	839186-1	INNER TRAY		1		
A06	813P13-6	JV102DSAJ INDICATION LABEL		1		
A07	813P14-4	JV102DSAJ PLASTIC CASE LABEL		2		
A08	197394-3	BATTERY BL1020B SET		2	*	
A08-1	197396-9	BATTERY BL1021B SET	<	2	*	
A08-2	197396-9	BATTERY BL1021B SET	O	2		
A09	***DC10SA	DC10SA BATTERY CHARGER		1	*	
A09-1	***DC10SB	DC10SB BATTERY CHARGER	<	1		
A10	456128-6	BATTERY COVER		1		
A06	813P20-9	JV102DSMJ INDICATION LABEL		1		
A07	813P21-7	JV102DSMJ PLASTIC CASE LABEL		2		
A08	197402-0	BATTERY BL1040B SET		2	*	

A08-1	197406-2	BATTERY BL1041B SET	<	2	*		
A08-2	197406-2	BATTERY BL1041B SET	O	2			

Please state Parts No. when your order.

Print Date 26.10.2023