

Model No.LF1000 FLIP OVER SAW 260MM

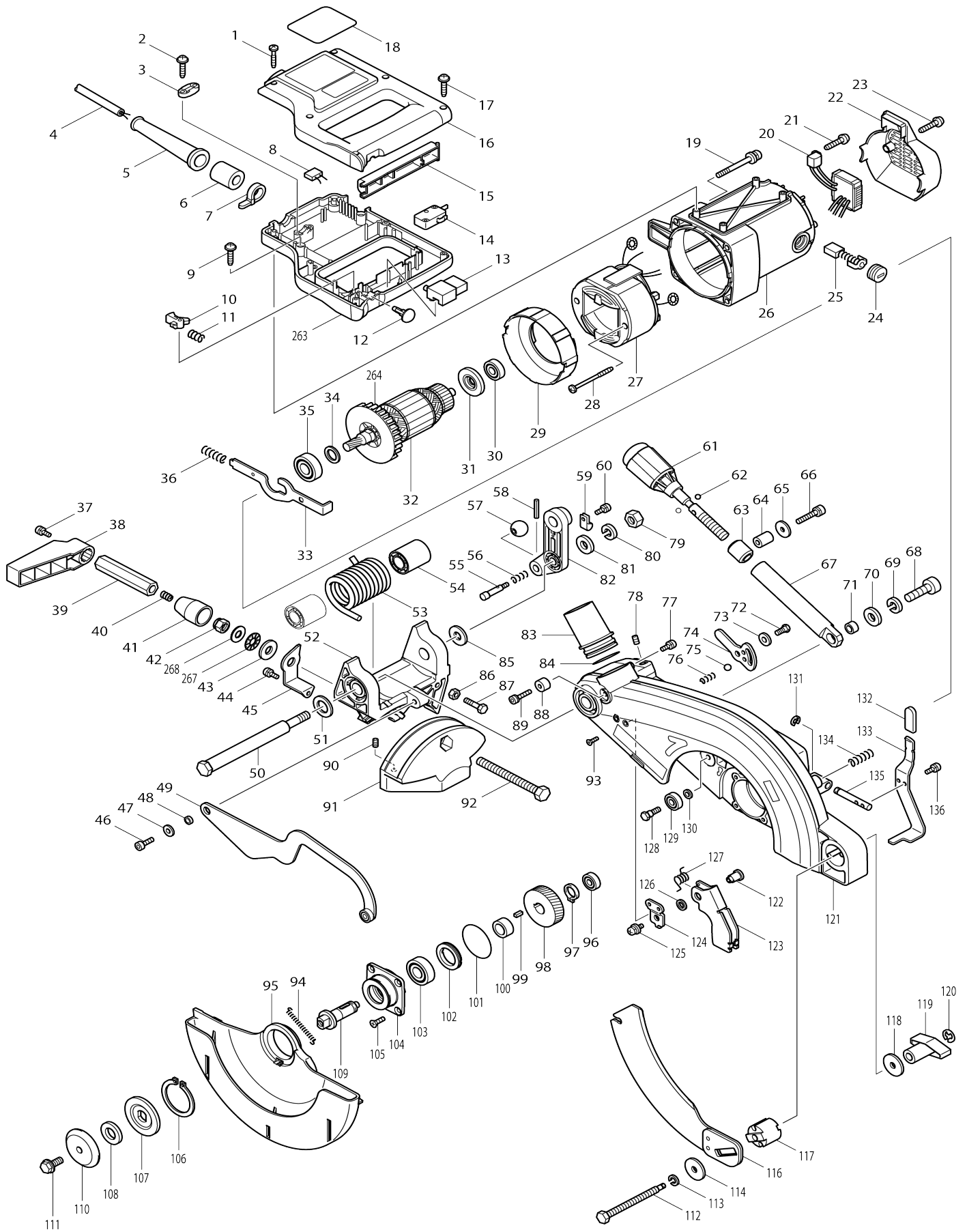

Model No.LF1000 FLIP OVER SAW 260MM

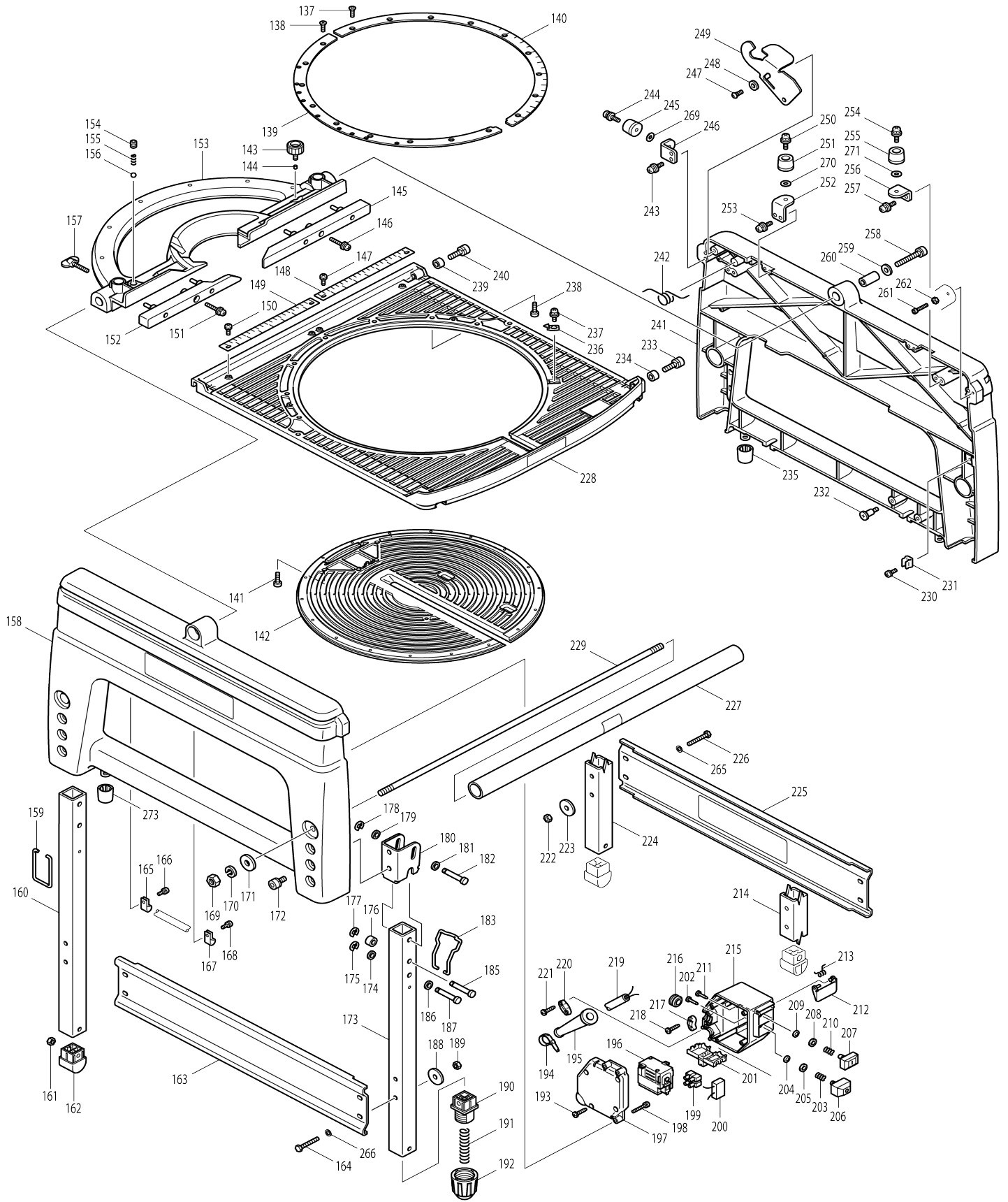

Model No.LF1000 FLIP OVER SAW 260MM

| Item No. | Parts No. | Description | Interchangeability | Q'ty | New/Old | Note1 | Note2 |
|----------|-----------|------------------------------|--------------------|------|---------|-------|-------|
| 001 | 265999-8 | TAPPING SCREW 4X25 | | 2 | | | |
| 002 | 265995-6 | TAPPING SCREW 4X18 | | 2 | | | |
| 003 | 687054-0 | STRAIN RELIEF | | 1 | * | | |
| 003-1 | 687149-9 | STRAIN RELIEF | O | 1 | | | |
| 004 | 662971-5 | POWER SUPPLY CORD 1.0-6-1.56 | | 1 | | | |
| 005 | 682506-6 | CORD GUARD 12-90 | | 1 | | | |
| 006 | 688140-0 | LINE FILTER | | 1 | | | |
| 007 | 687010-0 | BAND | | 1 | | | |
| 008 | 645006-7 | NOISE SUPPRESSOR | | 1 | | | |
| 009 | 265995-6 | TAPPING SCREW 4X18 | | 2 | | | |
| 010 | 416356-5 | LOCK-OFF LEVER | | 1 | | | |
| 011 | 231026-3 | COMPRESSION SPRING 4 | | 1 | * | | |
| 011-1 | 233483-1 | COMPRESSION SPRING 4 | O | 1 | | | |
| 012 | 416404-0 | SWITCH BUTTON | | 1 | * | | |
| 012-1 | 451037-4 | SWITCH BUTTON | < | 1 | | | |
| 013 | 651923-1 | SWITCH TG70B | | 1 | | | |
| 014 | 651941-9 | SWITCH V-15-2A5 | | 1 | | | |
| 015 | 416357-3 | SWITCH LEVER | | 1 | * | | |
| 015-1 | 458790-3 | SWITCH LEVER | < | 1 | | | |
| 016 | 154574-4 | HANDLE COVER COMPLETE | | 1 | * | | |
| C10 | 810087-2 | CAUTION LABEL | | 1 | * | | |
| 016-1 | 188063-7 | HANDLE SET | S | 1 | | | |
| C10 | 810087-2 | CAUTION LABEL | | 1 | | | |
| D10 | | INC. 263 | | | | | |
| 017 | 265995-6 | TAPPING SCREW 4X18 | | 4 | | | |
| 018 | 861365-3 | LF1000 NAME PLATE | | 1 | | | |
| 019 | 911383-2 | PAN HEAD SCREW M6X60 | | 4 | | | |
| 020 | 631661-1 | CONTROLLER | | 1 | * | | |
| 020-1 | 631947-3 | CONTROLLER | < | 1 | | | |
| 021 | 265995-6 | TAPPING SCREW 4X18 | | 1 | | | |
| 022 | 416362-0 | REAR COVER | | 1 | | | |
| 023 | 265995-6 | TAPPING SCREW 4X18 | | 2 | | | |
| 024 | 643650-4 | BRUSH HOLDER CAP 6.5-13.5 | | 2 | * | | |
| 024-1 | 643650-4 | BRUSH HOLDER CAP 6.5-13.5 | O | 2 | | | |
| 025 | 181044-0 | CARBON BRUSH CB-153 | | 1 | | | |
| 026 | 154569-7 | MOTOR HOUSING COMPLETE | | 1 | | | |
| C10 | 643660-1 | BRUSH HOLDER 6.5-13.5 | | 2 | * | | |
| C11 | 643653-8 | BRUSH HOLDER 6.5-13.5 | O | 2 | * | | |
| C14 | 643536-2 | BRUSH HOLDER 6.5X13.5 | < | 2 | * | | |
| C20 | 810086-4 | CAUTION LABEL | | 1 | | | |
| 027 | 596273-6 | FIELD ASS'Y 220-240V | | 1 | | | |
| C10 | 654020-2 | RING TERMINAL | | 2 | | | |
| C20 | 654502-4 | CONNECTOR P-2 | | 2 | | | |
| 028 | 266044-2 | TAPPING SCREW 5X60 | | 2 | | | |
| 029 | 416361-2 | BAFFLE PLATE | | 1 | | | |
| 030 | 211061-7 | BALL BEARING 6000LLB | | 1 | | | |
| 031 | 681642-5 | INSULATION WASHER | | 1 | | | |
| | | | | | | | |

| | | | | | | |
|-------|----------|------------------------------|---|---|---|--|
| 032 | 516748-9 | ARMATURE ASS'Y 220-240V | | 1 | | |
| D10 | | INC. 30,31,34,35,264 | | | | |
| 033 | 345574-7 | SHAFT LOCK | | 1 | | |
| 034 | 253147-1 | FLAT WASHER 15 | | 1 | * | |
| 034-1 | 267320-7 | FLAT WASHER 15 | O | 1 | | |
| 035 | 211206-7 | BALL BEARING 6202LLB | | 1 | | |
| 036 | 231297-2 | COMPRESSION SPRING 9 | | 1 | * | |
| 036-1 | 233467-9 | COMPRESSION SPRING 9 | O | 1 | | |
| 037 | 911113-1 | PAN HEAD SCREW M4X10 WITH WR | | 1 | | |
| 038 | 416006-2 | LEVER 100 | | 1 | | |
| 039 | 252192-3 | HEX.NUT M10-17 | | 1 | | |
| 040 | 231266-3 | COMPRESSION SPRING 5 | | 1 | * | |
| 040-1 | 233465-3 | COMPRESSION SPRING 5 | O | 1 | * | |
| 040-2 | 231266-3 | COMPRESSION SPRING 5 | O | 1 | | |
| 041 | 331691-9 | SPACER | | 1 | | |
| 042 | 252130-5 | HEX. LOCK NUT M10-17 | | 1 | * | |
| 042-1 | 264005-6 | HEX. LOCK NUT M10-17 | O | 1 | | |
| 043 | 253197-6 | FLAT WASHER 10 | | 1 | | |
| 044 | 911113-1 | PAN HEAD SCREW M4X10 WITH WR | | 1 | | |
| 045 | 816825-0 | INDICATION PLATE | | 1 | | |
| 046 | 922332-4 | HEX. SOCKET HEAD BOLT M6X20 | | 1 | * | |
| 046-1 | 265551-2 | HEX. SOCKET HEAD BOLT M6X20 | O | 1 | | |
| 047 | 253804-1 | FLAT WASHER 6 | | 1 | * | |
| 047-1 | 267325-7 | FLAT WASHER 6 | O | 1 | | |
| 048 | 257270-4 | RING 6 | | 1 | | |
| 049 | 154573-6 | LINK PLATE COMPLETE | | 1 | * | |
| 049-1 | 141540-0 | LINK PLATE COMPLETE | < | 1 | | |
| 050 | 265532-6 | HEX.BOLT M10 | | 1 | | |
| 051 | 253707-9 | FLAT WASHER 16 | | 1 | * | |
| 051-1 | 267323-1 | FLAT WASHER 16 | O | 1 | | |
| 052 | 154570-2 | ARM COMPLETE | | 1 | * | |
| C10 | 816833-1 | BEVEL SCALE LABEL | | 1 | * | |
| 052-1 | 141133-3 | ARM COMPLETE | < | 1 | | |
| C10 | 816833-1 | BEVEL SCALE LABEL | | 1 | | |
| 053 | 231681-1 | TORSION SPRING 34 | | 1 | | |
| 054 | 416358-1 | SLEEVE 17 | | 2 | | |
| 055 | 256488-4 | PIN 7 | | 1 | | |
| 056 | 233429-7 | COMPRESSION SPRING 7 | | 1 | | |
| 057 | 271601-3 | KNOB 20 | | 1 | | |
| 058 | 951063-8 | SPRING PIN 3-16 | | 1 | | |
| 059 | 687049-3 | STRAIN RELIEF | | 1 | | |
| 060 | 911113-1 | PAN HEAD SCREW M4X10 WITH WR | | 1 | | |
| 061 | 271319-6 | KNOB 40 | | 1 | | |
| 062 | 216013-3 | STEEL BALL 6 | | 2 | * | |
| 062-1 | 216030-3 | STEEL BALL 6 | O | 2 | | |
| 063 | 257750-0 | SLEEVE 13 | | 1 | | |
| 064 | 257748-7 | SLEEVE 6 | | 1 | | |
| 065 | 267173-4 | FLAT WASHER 6 | | 1 | * | |
| 065-1 | 267313-4 | FLAT WASHER 6 | O | 1 | | |
| | | | | | | |

| | | | | | | | |
|-------|----------|--------------------------------|---|---|---|--|--|
| 066 | 922351-0 | HEX. SOCKET HEAD BOLT M6X30 | | 1 | * | | |
| 066-1 | 265552-0 | HEX. SOCKET HEAD BOLT M6X30 | O | 1 | | | |
| 067 | 331689-6 | ADJUST NUT | | 1 | | | |
| 068 | 922557-0 | HEX. SOCKET HEAD BOLT M10X35 | | 1 | | | |
| 069 | 942251-8 | SPRING WASHER 10 | | 1 | | | |
| 070 | 941252-3 | FLAT WASHER 10 | | 1 | | | |
| 071 | 257747-9 | SLEEVE 10 | | 1 | | | |
| 072 | 265984-1 | HEX.SOCKET BUTTON HEAD BOLT M6 | | 1 | | | |
| 073 | 253823-7 | FLAT WASHER 7 | | 1 | * | | |
| 073-1 | 267326-5 | FLAT WASHER 7 | O | 1 | | | |
| 074 | 345553-5 | STOPPER PLATE | | 1 | | | |
| 075 | 216004-4 | STEEL BALL 7.9 | | 1 | | | |
| 076 | 231038-6 | COMPRESSION SPRING 6 | | 1 | * | | |
| 076-1 | 233466-1 | COMPRESSION SPRING 6 | O | 1 | | | |
| 077 | 911113-1 | PAN HEAD SCREW M4X10 WITH WR | | 1 | | | |
| 078 | 266085-8 | H.S.SET SCREW(FLAT POINT)M6X10 | | 1 | | | |
| 079 | 931502-4 | HEX. NUT M10 | | 1 | | | |
| 080 | 942251-8 | SPRING WASHER 10 | | 1 | | | |
| 081 | 941252-3 | FLAT WASHER 10 | | 1 | | | |
| 082 | 317889-2 | CONNECTING ROD | | 1 | | | |
| 083 | 416133-5 | DUST NOZZLE | | 1 | * | | |
| 083-1 | 419277-0 | DUST NOZZLE | O | 1 | | | |
| 084 | 213460-9 | O RING 35 | | 1 | | | |
| 085 | 253197-6 | FLAT WASHER 10 | | 1 | | | |
| 086 | 931302-2 | HEX. NUT M6 | | 1 | | | |
| 087 | 921342-8 | HEX. BOLT M6X25 | | 1 | | | |
| 088 | 257746-1 | SLEEVE 5 | | 1 | | | |
| 089 | 922231-0 | HEX. SOCKET HEAD BOLT M5X20 | | 1 | * | | |
| 089-1 | 265550-4 | HEX. SOCKET HEAD BOLT M5X20 | O | 1 | | | |
| 090 | 266085-8 | H.S.SET SCREW(FLAT POINT)M6X10 | | 2 | | | |
| 091 | 317887-6 | SUB ARM | | 1 | | | |
| 092 | 266377-5 | BOLT M10 | | 1 | | | |
| 093 | 912112-6 | COUNTERSUNK HEAD SCREW M4X10 | | 2 | | | |
| 094 | 231836-8 | TENSION SPRING 4 | | 1 | | | |
| 095 | 418922-4 | SAFETY COVER | | 1 | * | | |
| 095-1 | 453711-0 | SAFETY COVER | < | 1 | | | |
| 096 | 211031-6 | BALL BEARING 608LLB | | 1 | * | | |
| 096-1 | 210043-6 | BALL BEARING 608LLB | O | 1 | | | |
| 097 | 961055-9 | RETAINING RING S-15 | | 1 | | | |
| 098 | 226600-0 | HELICAL GEAR 46 | | 1 | | | |
| 099 | 254202-2 | KEY 4 | | 1 | | | |
| 100 | 257266-5 | RING 15 | | 1 | | | |
| 101 | 213623-7 | O RING 46 | | 1 | | | |
| 102 | 285808-5 | BEARING RETAINER 25-36 | | 1 | * | | |
| 102-1 | 285846-7 | BEARING RETAINER 25-36 | O | 1 | | | |
| 103 | 211206-7 | BALL BEARING 620LLB | | 1 | | | |
| 104 | 317888-4 | BEARING BOX | | 1 | | | |
| | | | | | | | |

| | | | | | | |
|-------|----------|-------------------------------|---|---|---|--|
| 105 | 912222-9 | COUNTERSUNK HEAD SCREW M5 X16 | | 4 | | |
| 106 | 961201-4 | RETAINING RING S-42 | | 1 | | |
| 107 | 224333-1 | FLANGE 53 | | 1 | | |
| 108 | 257262-3 | RING 16 | | 1 | * | |
| 108-1 | 257295-8 | RING 16 | O | 1 | | |
| 109 | 324543-1 | SPINDLE | | 1 | | |
| 110 | 224400-2 | OUTER FLANGE 53 | | 1 | | |
| 111 | 265355-2 | HEX. FLANGE HEAD BOLT M8X20 | | 1 | * | |
| 111-1 | 266762-2 | HEX. SOCKET HEAD BOLT M8X22 | < | 1 | | |
| 112 | 265534-2 | HEX.BOLT M8X86 | | 1 | * | |
| 112-1 | 266763-0 | HEX. SOCKET HEAD BOLT M8X97 | < | 1 | | |
| 113 | 942201-3 | SPRING WASHER 8 | | 1 | | |
| 114 | 267009-7 | FLAT WASHER 8 | | 1 | * | |
| 114-1 | 267312-6 | FLAT WASHER 8 | O | 1 | | |
| 116 | 163461-6 | RIVING KNIFE | | 1 | | |
| 117 | 331690-1 | KNIFE SUPPORT | | 1 | | |
| 118 | 267009-7 | FLAT WASHER 8 | | 1 | * | |
| 118-1 | 267312-6 | FLAT WASHER 8 | O | 1 | | |
| 119 | 252641-0 | WING NUT M8 | | 1 | | |
| 120 | 961011-9 | STOP RING E-4 | | 1 | | |
| 121 | 154571-0 | BLADE CASE COMPLETE | | 1 | | |
| C10 | 268076-5 | PIN 6 | | 2 | | |
| C20 | 817667-5 | CAUTION LABEL | | 1 | | |
| C30 | 819174-4 | MAKITA LOGO LABEL | | 1 | | |
| C40 | 951163-4 | SPRING PIN 5-20 | | 1 | | |
| 122 | 324497-2 | GUARD SHAFT | | 1 | * | |
| 122-1 | 324664-9 | GUARD SHAFT | O | 1 | | |
| 123 | 345554-3 | GUARD | | 1 | | |
| 124 | 345558-5 | GUARD HOLDER | | 1 | | |
| 125 | 911213-7 | PAN HEAD SCREW M5X12 | | 1 | | |
| 126 | 267070-4 | FLAT WASHER 10 | | 1 | * | |
| 126-1 | 267327-3 | FLAT WASHER 10 | O | 1 | | |
| 127 | 231675-6 | TORSION SPRING 11 | | 1 | | |
| 128 | 265533-4 | HEX.BOLT M6 | | 1 | | |
| 129 | 211031-6 | BALL BEARING 608LLB | | 1 | * | |
| 129-1 | 210043-6 | BALL BEARING 608LLB | O | 1 | | |
| 130 | 267173-4 | FLAT WASHER 6 | | 1 | * | |
| 130-1 | 267313-4 | FLAT WASHER 6 | O | 1 | | |
| 131 | 961012-7 | STOP RING E-6 | | 1 | | |
| 132 | 421589-9 | CAP | | 1 | | |
| 133 | 345552-7 | LOCK LEVER | | 1 | | |
| 134 | 231297-2 | COMPRESSION SPRING 9 | | 1 | * | |
| 134-1 | 233467-9 | COMPRESSION SPRING 9 | O | 1 | | |
| 135 | 256855-3 | ROD 8 | | 1 | | |
| 136 | 911113-1 | PAN HEAD SCREW M4X10 WITH WR | | 2 | | |
| 137 | 912112-6 | COUNTERSUNK HEAD SCREW M4 X10 | | 9 | | |
| 138 | 912112-6 | COUNTERSUNK HEAD SCREW M4 X10 | | 9 | | |
| 139 | 345541-2 | SLIDE PLATE L | | 1 | | |
| 140 | 345542-0 | SLIDE PLATE R | | 1 | | |

| | | | | | | | |
|-------|----------|---------------------------------|---|---|---|--|--|
| 141 | 922332-4 | HEX. SOCKET HEAD BOLT M6X20 | | 4 | * | | |
| 141-1 | 265551-2 | HEX. SOCKET HEAD BOLT M6X20 | O | 4 | | | |
| 142 | 154575-2 | TURN TABLE COMPLETE | | 1 | * | | |
| C10 | 256253-1 | PIN 5 | | 1 | * | | |
| 142-1 | 141631-7 | TURN TABLE COMPLETE | < | 1 | | | |
| C10 | 256253-1 | PIN 5 | | 1 | | | |
| 143 | 251815-0 | SCREW M6X25 | | 1 | | | |
| 144 | 268068-4 | PIN 5 | | 1 | | | |
| 145 | 154578-6 | SUB FENCE R COMPLETE | | 1 | * | | |
| C10 | 268076-5 | PIN 6 | | 2 | * | | |
| 146 | 911258-5 | PAN HEAD SCREW M5X35 | | 1 | * | | |
| 147 | 911113-1 | PAN HEAD SCREW M4X10 WITH WR | | 2 | | | |
| 148 | 816827-6 | SCALE PLATE R | | 1 | | | |
| 149 | 816826-8 | SCALE PLATE L | | 1 | | | |
| 150 | 911113-1 | PAN HEAD SCREW M4X10 WITH WR | | 2 | | | |
| 151 | 911258-5 | PAN HEAD SCREW M5X35 | | 1 | * | | |
| 152 | 154577-8 | SUB FENCE L COMPLETE | | 1 | * | | |
| C10 | 268076-5 | PIN 6 | | 2 | * | | |
| 153 | 154576-0 | GUIDE FENCE COMPLETE | | 1 | * | | |
| C10 | 256253-1 | PIN 5 | | 2 | * | | |
| 153-1 | 141586-6 | GUIDE FENCE COMPLETE | < | 1 | * | | |
| C10 | 256253-1 | PIN 5 | | 2 | * | | |
| 153-2 | 142820-7 | GUIDE FENCE COMPLETE | < | 1 | | | |
| C10 | 256253-1 | PIN 5 | | 2 | | | |
| 154 | 251966-9 | H.S.SET SCREW(FLATPOINT)M10X 12 | | 1 | * | | |
| 154-1 | 266392-9 | H.S.SET SCREW(FLATPOINT)M10X 12 | O | 1 | | | |
| 155 | 231038-6 | COMPRESSION SPRING 6 | | 1 | * | | |
| 155-1 | 233466-1 | COMPRESSION SPRING 6 | O | 1 | | | |
| 156 | 216004-4 | STEEL BALL 7.9 | | 1 | | | |
| 157 | 265710-8 | THUMB SCREW M6X33 | | 1 | | | |
| 158 | 188010-8 | FRAME SET | | 1 | * | | |
| D10 | | INC. 273 | | | | | |
| 158-1 | 188862-7 | FRAME SET | < | 1 | | | |
| D10 | | INC. 273 | | | | | |
| 159 | 345547-0 | HOOK | | 1 | | | |
| 160 | 331687-0 | SQUARE PIPE 32-510 | | 1 | | | |
| 161 | 931302-2 | HEX. NUT M6 | | 3 | | | |
| 162 | 418927-4 | FOOT | | 3 | | | |
| 163 | 154592-2 | SUPPORT BRACKET COMPLETE | | 1 | | | |
| C10 | 816831-5 | INDICATION LABEL | | 1 | | | |
| 164 | 921367-2 | HEX. BOLT M6X45 | | 4 | | | |
| 165 | 687049-3 | STRAIN RELIEF | | 1 | | | |
| 166 | 911113-1 | PAN HEAD SCREW M4X10 WITH WR | | 1 | | | |
| 167 | 687049-3 | STRAIN RELIEF | | 1 | | | |
| 168 | 911113-1 | PAN HEAD SCREW M4X10 WITH WR | | 1 | | | |
| 169 | 931502-4 | HEX. NUT M10 | | 4 | | | |
| 170 | 942251-8 | SPRING WASHER 10 | | 4 | | | |
| | | | | | | | |

| | | | | | | | |
|-------|----------|-----------------------------|---|---|---|--|--|
| 171 | 267087-7 | FLAT WASHER 10 | | 4 | * | | |
| 171-1 | 267328-1 | FLAT WASHER 10 | O | 4 | | | |
| 172 | 922431-2 | HEX. SOCKET HEAD BOLT M8X20 | | 8 | * | | |
| 172-1 | 265553-8 | HEX. SOCKET HEAD BOLT M8X20 | O | 8 | | | |
| 173 | 331686-2 | SQUARE PIPE 32-475 | | 1 | | | |
| 174 | 253165-9 | FLAT WASHER 8 | | 2 | * | | |
| 174-1 | 267321-5 | FLAT WASHER 8 | O | 2 | | | |
| 175 | 961012-7 | STOP RING E-6 | | 2 | | | |
| 176 | 257749-5 | SLEEVE 8 | | 4 | | | |
| 177 | 961012-7 | STOP RING E-6 | | 4 | | | |
| 178 | 961012-7 | STOP RING E-6 | | 4 | | | |
| 179 | 253165-9 | FLAT WASHER 8 | | 4 | * | | |
| 179-1 | 267321-5 | FLAT WASHER 8 | O | 4 | | | |
| 180 | 345543-8 | BRACKET | | 4 | | | |
| 181 | 253165-9 | FLAT WASHER 8 | | 4 | * | | |
| 181-1 | 267321-5 | FLAT WASHER 8 | O | 4 | | | |
| 182 | 268127-4 | PIN 8 | | 4 | | | |
| 183 | 345548-8 | STOPPER HOOK | | 2 | | | |
| 185 | 268127-4 | PIN 8 | | 4 | | | |
| 186 | 253165-9 | FLAT WASHER 8 | | 2 | * | | |
| 186-1 | 267321-5 | FLAT WASHER 8 | O | 2 | | | |
| 187 | 268141-0 | PIN 8 | | 2 | | | |
| 188 | 267009-7 | FLAT WASHER 8 | | 4 | * | | |
| 188-1 | 267312-6 | FLAT WASHER 8 | O | 4 | | | |
| 189 | 931302-2 | HEX. NUT M6 | | 4 | | | |
| 190 | 418925-8 | FOOT BOLT | | 1 | | | |
| 191 | 233087-9 | COMPRESSION SPRING 13 | | 1 | * | | |
| 191-1 | 233468-7 | COMPRESSION SPRING 13 | O | 1 | | | |
| 192 | 418926-6 | FOOT NUT | | 1 | | | |
| 193 | 265995-6 | TAPPING SCREW 4X18 | | 4 | | | |
| 194 | 687209-7 | BAND | | 1 | | | |
| 195 | 682540-6 | CORD GUARD 9.3-90 | | 1 | | | |
| 196 | 652772-9 | RELAY 305.232.01 | | 1 | * | | |
| 196-1 | 652772-9 | RELAY 305.232.01 | O | 1 | | | |
| 197 | 418924-0 | SWITCH BOX COVER | | 1 | | | |
| 198 | 911148-2 | PAN HEAD SCREW M4X25 | | 3 | | | |
| 199 | 654561-8 | TERMINAL BLOCK | | 1 | | | |
| 200 | 645206-9 | NOISE SUPPRESSOR | | 1 | | | |
| 201 | 686035-1 | RECEPTACLE SLEEVE | | 5 | | | |
| 202 | 418618-7 | PIN | | 1 | | | |
| 203 | 231025-5 | COMPRESSION SPRING 8 | | 1 | * | | |
| 203-1 | 233464-5 | COMPRESSION SPRING 8 | O | 1 | | | |
| 204 | 443103-1 | FELT RING 6 | | 1 | | | |
| 205 | 253186-1 | FLAT WASHER 7 | | 1 | * | | |
| 205-1 | 267322-3 | FLAT WASHER 7 | O | 1 | | | |
| 206 | 418617-9 | SWITCH BUTTON OFF | | 1 | | | |
| 207 | 418616-1 | SWITCH BUTTON ON | | 1 | | | |
| 208 | 253186-1 | FLAT WASHER 7 | | 1 | * | | |
| 208-1 | 267322-3 | FLAT WASHER 7 | O | 1 | | | |
| 209 | 443103-1 | FELT RING 6 | | 1 | | | |
| 210 | 231025-5 | COMPRESSION SPRING 8 | | 1 | * | | |
| 210-1 | 233464-5 | COMPRESSION SPRING 8 | O | 1 | | | |

| | | | | | | |
|-------|----------|------------------------------|---|---|---|--|
| 211 | 418618-7 | PIN | | 1 | | |
| 212 | 418929-0 | SWITCH COVER | | 1 | | |
| 213 | 231682-9 | TORSION SPRING 5 | | 1 | | |
| 214 | 331686-2 | SQUARE PIPE 32-475 | | 1 | | |
| 215 | 418923-2 | SWITCH BOX | | 1 | | |
| 216 | 682511-3 | GROMMET | | 1 | * | |
| 216-1 | 682103-8 | GROMMET | < | 1 | | |
| 217 | 687054-0 | STRAIN RELIEF | | 1 | * | |
| 217-1 | 687149-9 | STRAIN RELIEF | O | 1 | | |
| 218 | 265995-6 | TAPPING SCREW 4X18 | | 2 | | |
| 219 | 665865-3 | POWER SUPPLY CORD 1.0-2-2.5 | | 1 | | |
| 220 | 687052-4 | STRAIN RELIEF | | 1 | * | |
| 220-1 | 687124-5 | STRAIN RELIEF | O | 1 | | |
| 221 | 265995-6 | TAPPING SCREW 4X18 | | 2 | | |
| 222 | 931302-2 | HEX. NUT M6 | | 4 | | |
| 223 | 267009-7 | FLAT WASHER 8 | | 4 | * | |
| 223-1 | 267312-6 | FLAT WASHER 8 | O | 4 | | |
| 224 | 331686-2 | SQUARE PIPE 32-475 | | 1 | | |
| 225 | 345546-2 | SUPPORT BRACKET | | 1 | | |
| 226 | 921367-2 | HEX. BOLT M6X45 | | 4 | | |
| 227 | 154593-0 | PIPE 32 COMPLETE | | 2 | | |
| C10 | 819212-2 | MAKITA LOGO LABEL | | 2 | | |
| 228 | 154572-8 | TABLE COMPLETE | | 1 | | |
| C10 | 810086-4 | CAUTION LABEL | | 1 | | |
| C20 | 810965-6 | CAUTION LABEL | | 1 | | |
| 229 | 266360-2 | SCREW M10 | | 2 | | |
| 230 | 911113-1 | PAN HEAD SCREW M4X10 WITH WR | | 1 | * | |
| 231 | 232075-3 | LEAF SPRING | | 1 | * | |
| 231-1 | 410047-0 | WRENCH HOLDER 5.6 | X | 1 | | |
| 232 | 266030-3 | SCREW M6 | | 2 | * | |
| 232-1 | 266391-1 | SHOULDER SCREW M6 | O | 2 | | |
| 233 | 922442-7 | HEX. SOCKET HEAD BOLT M8X25 | | 1 | * | |
| 233-1 | 265554-6 | HEX. SOCKET HEAD BOLT M8X25 | O | 1 | | |
| 234 | 257749-5 | SLEEVE 8 | | 1 | | |
| 235 | 418931-3 | CAP | | 2 | | |
| 236 | 816128-2 | POINTER | | 1 | * | |
| 236-1 | 816856-9 | INDICATION PLATE | O | 1 | | |
| 237 | 911108-4 | PAN HEAD SCREW M4X8 | | 1 | | |
| 238 | 922332-4 | HEX. SOCKET HEAD BOLT M6X20 | | 9 | * | |
| 238-1 | 265551-2 | HEX. SOCKET HEAD BOLT M6X20 | O | 9 | | |
| 239 | 257749-5 | SLEEVE 8 | | 1 | | |
| 240 | 922442-7 | HEX. SOCKET HEAD BOLT M8X25 | | 1 | * | |
| 240-1 | 265554-6 | HEX. SOCKET HEAD BOLT M8X25 | O | 1 | | |
| 241 | 188010-8 | FRAME SET | | 1 | * | |
| D10 | | INC. 235 | | | | |
| 241-1 | 188862-7 | FRAME SET | < | 1 | | |
| D10 | | INC. 235 | | | | |
| 242 | 231680-3 | TORSION SPRING 17 | | 1 | | |
| 243 | 911333-7 | PAN HEAD SCREW M6X20 | | 4 | | |
| 244 | 911333-7 | PAN HEAD SCREW M6X20 | | 2 | | |
| 245 | 421906-3 | CUSHION | | 2 | | |

| | | | | | | | |
|-------|----------|---------------------------------|---|---|---|--|--|
| 246 | 345550-1 | STOPPER BRACKET R | | 2 | | | |
| 247 | 265984-1 | HEX.SOCKET BUTTON HEAD BOL T M6 | | 2 | | | |
| 248 | 253823-7 | FLAT WASHER 7 | | 2 | * | | |
| 248-1 | 267326-5 | FLAT WASHER 7 | O | 2 | | | |
| 249 | 345551-9 | LEVER | | 1 | | | |
| 250 | 911333-7 | PAN HEAD SCREW M6X20 | | 2 | | | |
| 251 | 421906-3 | CUSHION | | 2 | | | |
| 252 | 345550-1 | STOPPER BRACKET R | | 2 | | | |
| 253 | 911333-7 | PAN HEAD SCREW M6X20 | | 4 | | | |
| 254 | 911333-7 | PAN HEAD SCREW M6X20 | | 2 | | | |
| 255 | 421906-3 | CUSHION | | 2 | | | |
| 256 | 345549-6 | STOPPER BRACKET F | | 2 | | | |
| 257 | 911333-7 | PAN HEAD SCREW M6X20 | | 4 | | | |
| 258 | 922471-0 | HEX. SOCKET HEAD BOLT M8X50 | | 2 | * | | |
| 258-1 | 265555-4 | HEX. SOCKET HEAD BOLT M8X50 | O | 2 | | | |
| 259 | 267236-6 | FLAT WASHER 8 | | 2 | * | | |
| 259-1 | 267399-8 | FLAT WASHER 8 | O | 2 | | | |
| 260 | 257751-8 | SLEEVE 8 | | 2 | | | |
| 261 | 922137-2 | HEX. SOCKET HEAD BOLT M4X20 | | 1 | * | | |
| 261-1 | 265549-9 | HEX. SOCKET HEAD BOLT M4X20 | O | 1 | | | |
| 262 | 931103-8 | HEX. NUT M4 | | 1 | * | | |
| 262-1 | 931102-0 | HEX. NUT M4 | O | 1 | | | |
| 263 | 416364-6 | HANDLE | | 1 | * | | |
| 263-1 | 188063-7 | HANDLE SET | S | 1 | | | |
| C10 | 810087-2 | CAUTION LABEL | | 1 | | | |
| D10 | | INC. 16 | | | | | |
| 264 | 240003-4 | FAN 80 | | 1 | | | |
| 265 | 941152-7 | FLAT WASHER 6 | | 4 | | | |
| 266 | 941152-7 | FLAT WASHER 6 | | 4 | | | |
| 267 | 216413-7 | THRUST NEEDLE CAGE 1024 | | 1 | | | |
| 268 | 253024-7 | FLAT WASHER 10 | | 1 | | | |
| 269 | 253047-5 | FLAT WASHER 6 | | 2 | * | | |
| 269-1 | 267319-2 | FLAT WASHER 6 | O | 2 | | | |
| 271 | 253047-5 | FLAT WASHER 6 | | 3 | * | | |
| 271-1 | 267319-2 | FLAT WASHER 6 | O | 3 | | | |
| 272 | 253047-5 | FLAT WASHER 6 | | 3 | * | | |
| 272-1 | 267319-2 | FLAT WASHER 6 | O | 3 | | | |
| 273 | 418931-3 | CAP | | 2 | | | |
| A01 | 122729-9 | RULER ASS'Y | | 1 | * | | |
| C10 | 154580-9 | RULE HOLDER COMPLETE | | 1 | * | | |
| C20 | 251858-2 | DIAL SCREW M6X15 | | 1 | * | | |
| C30 | 265730-2 | THUMB SCREW M6X35 | | 1 | * | | |
| C40 | 266085-8 | H.S.SET SCREW(FLAT POINT)M6X 10 | | 1 | * | | |
| C50 | 345424-6 | GUIDE PLATE | | 1 | * | | |
| C60 | 345557-7 | NUT PLATE | | 1 | * | | |
| D10 | | INC. A15 | | | | | |
| A01-1 | 122729-9 | RULER ASS'Y | O | 1 | | | |
| C10 | 251858-2 | DIAL SCREW M6X15 | | 1 | | | |
| C20 | 265730-2 | THUMB SCREW M6X35 | | 1 | | | |
| C30 | 266085-8 | H.S.SET SCREW(FLAT POINT)M6X | | 1 | | | |

| | | | | | | |
|-------|----------|----------------------------|---|---|---|--|
| | | 10 | | | | |
| C40 | 345692-1 | GUIDE PLATE | | 1 | | |
| C50 | 345557-7 | NUT PLATE | | 1 | * | |
| C51 | 346628-3 | NUT PLATE | < | 1 | | |
| C60 | 331692-7 | RULER A | | 1 | | |
| D10 | | INC. A15 | | | | |
| A02 | 122732-0 | DUST COVER ASS'Y | | 1 | * | |
| C10 | 252103-8 | HEX. LOCK NUT M5-8 | | 1 | * | |
| C20 | 265746-7 | THUMB SCREW M5X37 | | 1 | * | |
| A02-1 | 122732-0 | DUST COVER ASS'Y | O | 1 | | |
| C10 | 264004-8 | HEX. LOCK NUT M5-8 | | 1 | | |
| C20 | 265746-7 | THUMB SCREW M5X37 | | 1 | | |
| A03 | 122523-9 | DUST BAG ASS'Y | | 1 | * | |
| C10 | 410602-8 | FASTENER | | 1 | * | |
| A03-1 | 122852-0 | DUST BAG ASS'Y | O | 1 | | |
| C10 | 410602-8 | FASTENER | | 1 | | |
| A04 | 122728-1 | WISE ASS'Y | | 1 | * | |
| C10 | 251887-5 | SCREW M6X10 | | 1 | * | |
| C20 | 253804-1 | FLAT WASHER 6 | | 1 | * | |
| C30 | 265153-4 | + PAN HEAD SCREW M5 | | 1 | * | |
| C40 | 271303-1 | KNOB 40 | | 1 | * | |
| C50 | 317892-3 | WISE ARM | | 1 | * | |
| C60 | 322983-7 | WISE ROD | | 1 | * | |
| C70 | 345575-5 | WISE PLATE | | 1 | * | |
| A04-1 | 122728-1 | WISE ASS'Y | O | 1 | | |
| C10 | 251887-5 | SCREW M6X10 | | 1 | | |
| C20 | 267325-7 | FLAT WASHER 6 | | 1 | | |
| C30 | 265153-4 | + PAN HEAD SCREW M5 | | 1 | | |
| C40 | 271303-1 | KNOB 40 | | 1 | | |
| C50 | 317892-3 | WISE ARM | | 1 | | |
| C60 | 324663-1 | WISE ROD | | 1 | | |
| C70 | 345575-5 | WISE PLATE | | 1 | | |
| A05 | 122730-4 | ANGLE RULE ASS'Y | | 1 | * | |
| C10 | 163454-3 | GUIDE PLATE | | 1 | * | |
| C20 | 252631-3 | THUMB NUT M6 | | 1 | * | |
| C30 | 253047-5 | FLAT WASHER 6 | | 1 | * | |
| C40 | 271401-1 | KNOB 32 | | 1 | * | |
| C50 | 331693-5 | RULER B | | 1 | * | |
| C60 | 923326-2 | CUP SQUARE NECK BOLT M6X18 | | 1 | * | |
| A05-1 | 122730-4 | ANGLE RULE ASS'Y | O | 1 | | |
| C10 | 163454-3 | GUIDE PLATE | | 1 | | |
| C20 | 252631-3 | THUMB NUT M6 | | 1 | | |
| C30 | 267319-2 | FLAT WASHER 6 | | 1 | | |
| C40 | 271401-1 | KNOB 32 | | 1 | | |
| C50 | 331693-5 | RULER B | | 1 | | |
| C60 | 923326-2 | CUP SQUARE NECK BOLT M6X18 | | 1 | * | |
| C61 | 266371-7 | CUP SQUARE NECK BOLT M6X18 | O | 1 | | |
| A06 | 122731-2 | TOP COVER ASS'Y | | 1 | * | |
| C10 | 233307-1 | COMPRESSION SPRING 7 | | 1 | * | |
| C20 | 268129-0 | PIN 8 | | 1 | * | |
| C30 | 961012-7 | STOP RING E-6 | | 1 | * | |
| C40 | 817283-3 | CAUTION LABEL | | 1 | * | |

| | | | | | | | |
|-------|----------|------------------------------|---|---|---|--|--|
| A06-1 | 122731-2 | TOP COVER ASS'Y | O | 1 | * | | |
| C10 | 233469-5 | COMPRESSION SPRING 7 | | 1 | * | | |
| C20 | 268129-0 | PIN 8 | | 1 | * | | |
| C30 | 961012-7 | STOP RING E-6 | | 1 | * | | |
| C40 | 817283-3 | CAUTION LABEL | | 1 | * | | |
| A06-2 | 123104-2 | TOP COVER ASS'Y | < | 1 | | | |
| C10 | 233469-5 | COMPRESSION SPRING 7 | | 1 | | | |
| C20 | 268129-0 | PIN 8 | | 1 | | | |
| C30 | 961012-7 | STOP RING E-6 | | 1 | | | |
| C40 | 817283-3 | CAUTION LABEL | | 1 | | | |
| A07 | 345555-1 | FIX PLATE | | 3 | | | |
| A08 | 416368-8 | ELBOW | | 1 | | | |
| A09 | 419043-5 | PUSH STICK | | 1 | | | |
| A10 | 762001-3 | TRIANGULAR RULE | | 1 | | | |
| A11 | 921322-4 | HEX. BOLT M6X16 | | 3 | | | |
| A12 | 782230-2 | BOX WRENCH 13-3 | | 1 | * | | |
| A12-1 | 783204-6 | HEX. WRENCH 6 | X | 1 | | | |
| A14 | B-03838 | T.C.T.SAW BLADE 260X30X60T | | 1 | * | | |
| A14-1 | D-46408 | TCT SAW BLADE 260 X 30 X 60T | O | 1 | | | |
| A15 | 154580-9 | RULE HOLDER COMPLETE | | 1 | | | |
| C10 | 810191-7 | CAUTION LABEL | | 1 | | | |
| A17 | 783201-2 | HEX. WRENCH 3 | | 1 | | | |
| A18 | 123262-4 | SUB FENCE ASSEMBLY | | 1 | | | |
| C10 | 142819-2 | SUB FENCE COMPLETE | | 1 | | | |
| C20 | 213021-5 | O RING 5 | | 1 | | | |
| C30 | 265753-0 | THUMB SCREW M5X24 | | 1 | | | |

Please state Parts No. when your order.

Print Date 26.10.2023