

Model No.LH1040F TABLE TOP MITER SAW 260MM

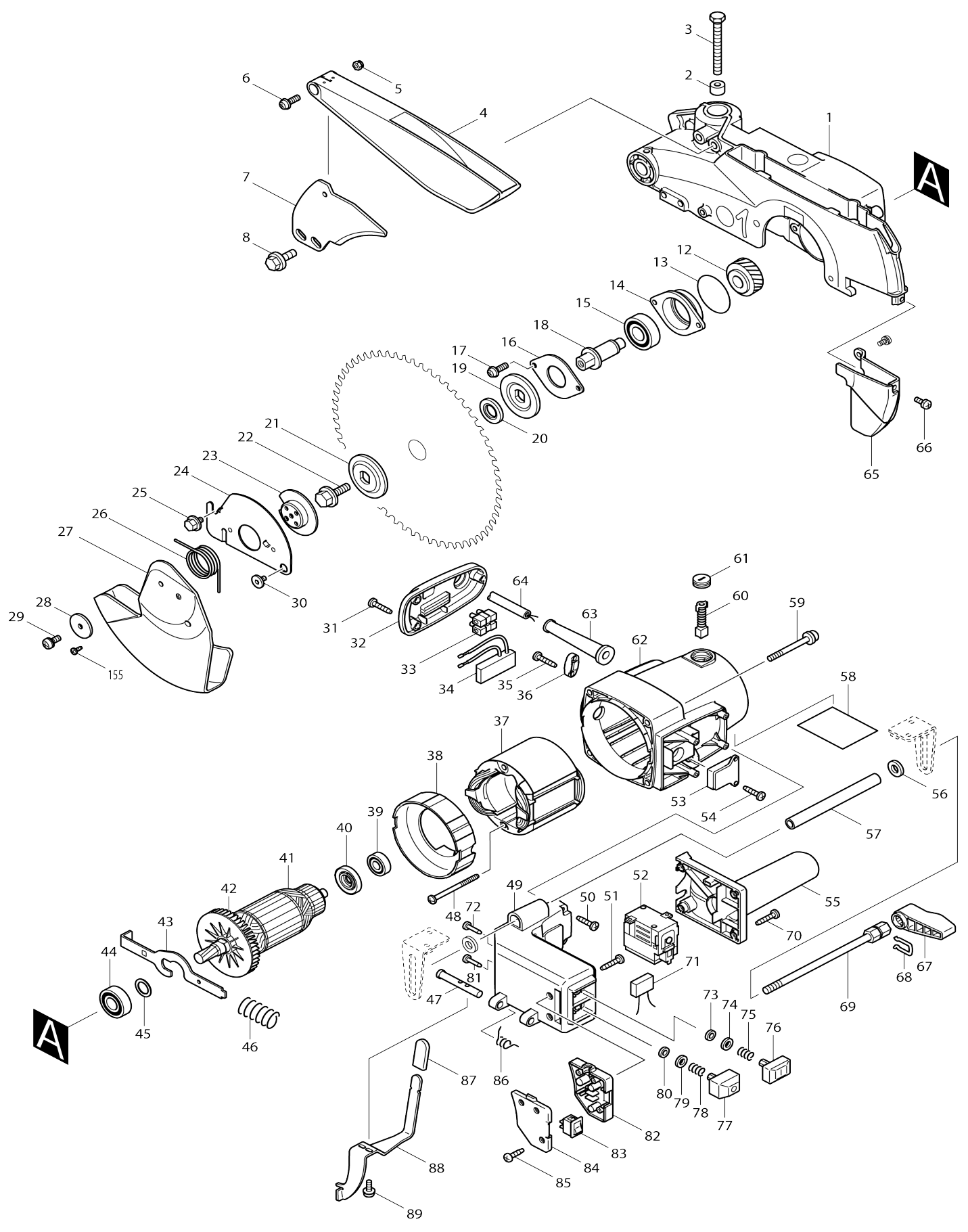

Model No.LH1040F TABLE TOP MITER SAW 260MM

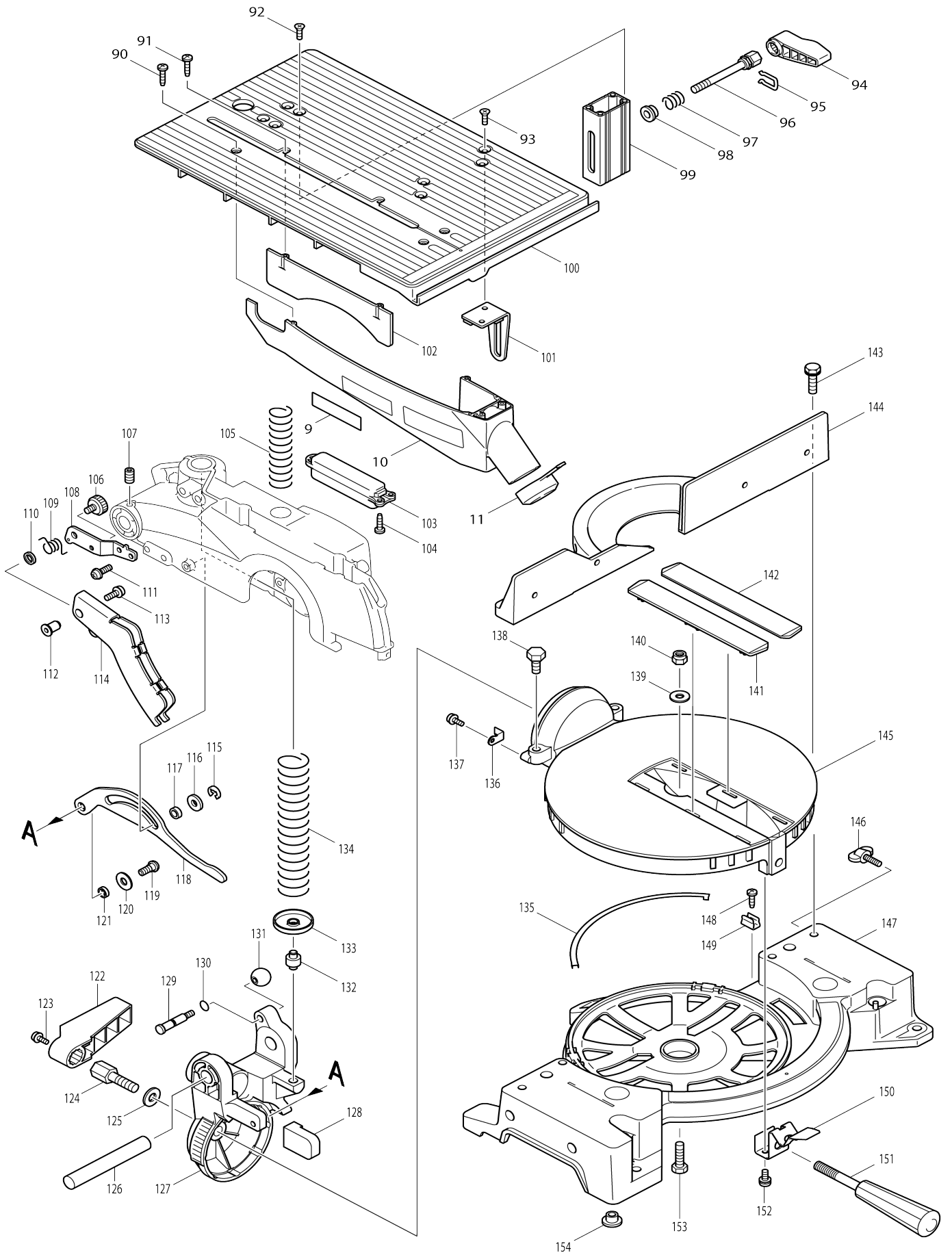

024	344380-7	CENTER COVER		1	*		
024-1	346516-4	CENTER COVER	O	1			
025	265324-3	HEX. FLANGE HEAD BOLT M8X12		1			
026	231593-8	TORSION SPRING 36		1			
027	418625-0	SAFETY COVER		1	*		
027-1	453026-5	SAFETY COVER	O	1			
028	267136-0	FLAT WASHER 5		1			
029	911213-7	PAN HEAD SCREW M5X12		1	*		
029-1	922211-6	H.S.H.BOLT M5X12 WITH W	<	1			
030	265985-9	HEX.SOCKET HEAD BOLT M6		1			
031	265995-6	TAPPING SCREW 4X18		3			
032	418620-0	HOUSING COVER		1			
033	654561-8	TERMINAL BLOCK		1			
034	631613-2	SOFT START CIRCUIT		1			
035	265995-6	TAPPING SCREW 4X18		2			
036	687052-4	STRAIN RELIEF		1	*		
036-1	687124-5	STRAIN RELIEF	O	1			
037	599519-9	FIELD ASS'Y 220-240V		1			
C10	654020-2	RING TERMINAL		2			
C20	654502-4	CONNECTOR P-2		2			
038	418621-8	BAFFLE PLATE		1			
039	211061-7	BALL BEARING 6000LLB		1			
040	681640-9	INSULATION WASHER		1	*		
040-1	681640-9	INSULATION WASHER	O	1			
041	516718-8	ARMATURE ASS'Y 220V		1	*		
D10		INC. 39,40,42,44,45					
041-1	516718-8	ARMATURE ASS'Y 220V	O	1			
D10		INC. 39,40,42,44,45					
042	241909-9	FAN 80		1			
043	343641-2	SHAFT LOCK		1			
044	211206-7	BALL BEARING 6202LLB		1			
045	267280-3	FLAT WASHER 15		1			
046	231297-2	COMPRESSION SPRING 9		1			
047	324496-4	LOCK PIN 8		1			
048	266029-8	TAPPING SCREW 5X65		2			
049	418630-7	SWITCH BOX		1			
050	265995-6	TAPPING SCREW 4X18		4			
051	265995-6	TAPPING SCREW 4X18		2			
052	652772-9	RELAY 305.232.01		1	*		
052-1	652772-9	RELAY 305.232.01	O	1			
053	153996-5	CLAMP PLATE COMPLETE		1			
054	266020-6	TAPPING SCREW 4X12		2			
055	153995-7	HANDLE COMPLETE		1			
056	941201-0	FLAT WASHER 8		2			
057	331683-8	PIPE 9-126		1			
058	860810-5	NAME PLATE LH1040F		1	*		
058-1	864416-1	LH1040F NAME PLATE	O	1			
059	911383-2	PAN HEAD SCREW M6X60		4			
060	181044-0	CARBON BRUSH CB-153		1			
061	643650-4	BRUSH HOLDER CAP 6.5-13.5		2	*		
061-1	643650-4	BRUSH HOLDER CAP 6.5-13.5	O	2			
062	153994-9	MOTOR HOUSING COMPLETE		1	*		

C10	643660-1	BRUSH HOLDER 6.5-13.5		2	*		
062-1	158561-5	MOTOR HOUSING COMPLETE	O	1			
C10	643653-8	BRUSH HOLDER 6.5-13.5		2	*		
C11	643536-2	BRUSH HOLDER 6.5X13.5	<	2			
063	682516-3	CORD GUARD 9.3-85		1			
064	665865-3	POWER SUPPLY CORD 1.0-2-2.5		1			
065	165389-4	BLADE GUARD		1	*		
065-1	165659-1	BLADE GUARD	O	1			
066	911206-4	PAN HEAD SCREW M5X10		2			
067	272230-5	LEVER 54		1			
068	231955-0	RING SPRING 12		1			
069	331682-0	LOCK BOLT M8X150		1			
070	265995-6	TAPPING SCREW 4X18		4			
071	645200-1	NOISE SUPPRESSOR		1			
072	418618-7	PIN		1			
073	443103-1	FELT RING 6		1			
074	253186-1	FLAT WASHER 7		1			
075	231025-5	COMPRESSION SPRING 8		1			
076	418616-1	SWITCH BUTTON ON		1			
077	418617-9	SWITCH BUTTON OFF		1			
078	231025-5	COMPRESSION SPRING 8		1			
079	253186-1	FLAT WASHER 7		1			
080	443103-1	FELT RING 6		1			
081	418618-7	PIN		1			
082	418623-4	LIGHT SWITCH BOX		1			
083	651522-9	SWITCH SLE6A		1			
084	418624-2	LIGHT SWITCH BOX COVER		1			
085	265893-4	TAPPING SCREW 3X12		3			
086	231674-8	TORSION SPRING 9		1			
087	421589-9	CAP		1			
088	345427-0	LOCK LEVER		1			
089	911113-1	PAN HEAD SCREW M4X10 WITH WR		2			
090	265995-6	TAPPING SCREW 4X18		3			
091	265995-6	TAPPING SCREW 4X18		2			
092	912222-9	COUNTERSUNK HEAD SCREW M5 X16		4			
093	912222-9	COUNTERSUNK HEAD SCREW M5 X16		4			
094	272230-5	LEVER 54		1			
095	231955-0	RING SPRING 12		1			
096	331681-2	LOCK BOLT M8X70		1			
097	233042-1	COMPRESSION SPRING 14		1			
098	257675-8	SLEEVE 8		1			
099	317779-9	TABLE SUPPORT		1			
100	153992-3	TABLE COMPLETE		1	*		
C10	816818-7	SCALE PLATE		1	*		
100-1	141630-9	TABLE COMPLETE	<	1			
C10	816818-7	SCALE PLATE		1			
101	165388-6	SUPPORT PLATE		2			
102	418619-5	UNDER GUARD R		1	*		
102-1	453029-9	UNDER GUARD R	O	1			

103	631611-6	LIGHT CIRCUIT		1		
104	266034-5	TAPPING SCREW CT 4X16		4		
105	233415-8	COMPRESSION SPRING 21		1		
106	251812-6	SCREW M5X10		1		
107	251961-9	H.S.SET SCREW(FLAT POINT)M6X 10		1		
108	345425-4	GUARD HOLDER		1		
109	231675-6	TORSION SPRING 11		1		
110	267070-4	FLAT WASHER 10		1		
111	911223-4	PAN HEAD SCREW M5X16		2		
112	324497-2	GUARD SHAFT		1		
113	911223-4	PAN HEAD SCREW M5X16		1		
114	345426-2	GUARD		1		
115	961018-5	STOP RING E-5		1		
116	253804-1	FLAT WASHER 6		1		
117	257163-5	RING 6		1		
118	344377-6	LINK PLATE		1		
119	265984-1	HEX.SOCKET BUTTON HEAD BOL T M6		1		
120	253823-7	FLAT WASHER 7		1		
121	257162-7	RING 7		1		
122	416006-2	LEVER 100		1		
123	911113-1	PAN HEAD SCREW M4X10 WITH WR		1		
124	265437-0	HEX. BOLT M10		1		
125	253024-7	FLAT WASHER 10		1		
126	256836-7	ROD 16		1		
127	154463-3	ARM COMPLETE		1	*	
127-1	141139-1	ARM COMPLETE	O	1		
128	421867-7	CAP		1		
129	324183-5	STOPPER PIN		1		
130	213021-5	O RING 5		1		
131	271601-3	KNOB 20		1		
132	256280-8	PIN 8		1		
133	344464-1	SPRING HOLDER		1		
134	233414-0	COMPRESSION SPRING 27		1		
135	343799-7	SLIDE PLATE		3		
136	344385-7	POINTER		1		
137	911113-1	PAN HEAD SCREW M4X10 WITH WR		1		
138	265455-8	HEX. BOLT M8X28		2		
139	253762-1	FLAT WASHER 8		1		
140	252105-4	HEX. LOCK NUT M8-13		1		
141	418615-3	KERF BOARD		1	*	
141-1	453028-1	KERF BOARD	O	1		
142	418615-3	KERF BOARD		1	*	
142-1	453028-1	KERF BOARD	O	1		
143	265488-3	HEX. BOLT M8X30		4		
144	317782-0	GUIDE FENCE		1	*	
144-1	318798-8	GUIDE FENCE	O	1	*	
144-2	318895-0	GUIDE FENCE	<	1	*	
144-3	319200-4	GUIDE FENCE	<	1		
145	316824-7	TURN BASE		1	*	

145-1	318800-7	TURN BASE	O	1			
146	265708-5	THUMB SCREW M6X20		1	*		
146-1	911333-7	PAN HEAD SCREW M6X20	<	2			
147	153998-1	BASE COMPLETE		1	*		
C10	816311-1	MITER SCALE PLATE		1	*		
C20	810965-6	CAUTION LABEL		1	*		
C30	817283-3	CAUTION LABEL		2	*		
147-1	141140-6	BASE COMPLETE	O	1			
C10	816311-1	MITER SCALE PLATE		1			
C20	810965-6	CAUTION LABEL		1			
C30	817283-3	CAUTION LABEL		2			
148	266034-5	TAPPING SCREW CT 4X16		1			
149	232075-3	LEAF SPRING		1			
150	344381-5	KNOCK SPRING		1			
151	273495-2	GRIP 32		1			
152	911213-7	PAN HEAD SCREW M5X12		2			
153	921452-1	HEX. BOLT M8X30		1			
154	286212-1	CAP 20		4			
155	265954-0	TAPPING SCREW BIND PT3X8		1			
A01	122472-0	SET PLATE ASS'Y		1	*		
C10	251887-5	SCREW M6X10		1	*		
A01-1	122472-0	SET PLATE ASS'Y	O	1			
C10	251887-5	SCREW M6X10		1			
A02	122523-9	DUST BAG ASS'Y		1	*		
C10	410602-8	FASTENER		1	*		
A02-1	122852-0	DUST BAG ASS'Y	<	1			
C10	410602-8	FASTENER		1			
A03	122707-9	RULER ASS'Y		1			
C10	165392-5	RULE HOLDER		1			
C20	251858-2	DIAL SCREW M6X15		1			
C30	265730-2	THUMB SCREW M6X35		1			
C40	345424-6	GUIDE PLATE		1			
C50	345440-8	LOCK PLATE		1			
C60	418662-4	RULE GUIDE		1			
C70	911159-7	PAN HEAD SCREW M4X30		2			
C80	941151-9	FLAT WASHER 6		1			
C90	317793-5	RULER		1			
A04	257022-3	RING 16		1			
A05	762001-3	TRIANGULAR RULE		1			
A06	122716-8	SUB PLATE ASS'Y		1			
C10	252148-6	SQUARE NUT M8		1			
C20	921431-9	HEX. BOLT M8X20		1			
C30	922206-9	HEX. SOCKET HEAD BOLT M5X10		2			
A07	322312-4	HOLDER		1	*		
A07-1	123101-8	HOLDER ASSEMBLY	<	2			
C10	286212-1	CAP 20		4			
C20	326182-3	HOLDER		2			
C30	332036-4	ADJUSTER		4			
A08	416772-1	PUSH STICK		1			
A09	418626-8	BLADE COVER		1	*		
A09-1	453727-5	BLADE COVER	<	1			

A10	B-03838	T.C.T.SAW BLADE 260X30X60T		1	*		
A10-1	D-46408	TCT SAW BLADE 260 X 30 X 60T	O	1			
A11	782212-4	SOCKET WRENCH 13		1			
A13	122536-0	WISE ASS'Y		1			
C10	251370-2	+ PAN HEAD SCREW M5		1			
C20	251887-5	SCREW M6X10		1			
C30	253804-1	FLAT WASHER 6		1			
C40	271286-5	KNOB 40		1			
C50	316938-2	WISE ARM		1			
C60	322313-2	WISE ROD		1			
C70	343651-9	WISE PLATE		1			
E05	346605-5	CAM PLATE		1			
E06	266026-4	TAPPING SCREW BIND CT 4X12		2			
E07	346606-3	GUARD PLATE		1			
E08	265011-4	+ BINDING HEAD SCREW M5		1			
E09	253823-7	FLAT WASHER 7		1			
E10	231684-5	TORSION SPRING 11		1			
E11	251887-5	SCREW M6X10		1			
E12	142817-6	SUB FENCE COMPLETE		1			
E13	253715-0	FLAT WASHER 6		1			
E14	265031-8	+ COUNTERSUNK HEAD SCREW M6X20		1			
E15	344476-4	SUB FENCE PLATE		1			
E16	931302-2	HEX. NUT M6		1			

Please state Parts No. when your order.

Print Date 12/04/2023