

Model No.LS0714 SLIDE COMPOUND SAW 190MM

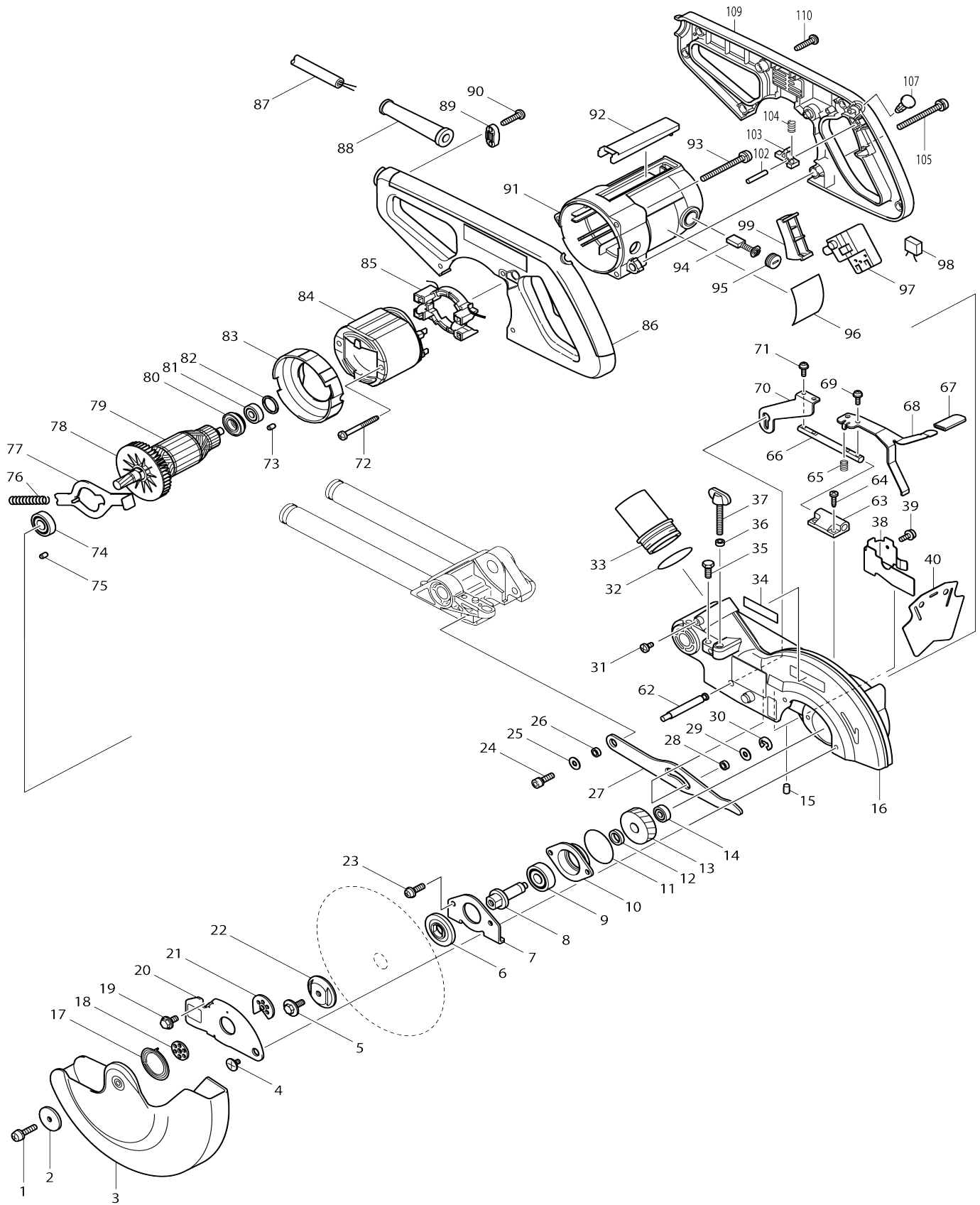

Model No.LS0714 SLIDE COMPOUND SAW 190MM

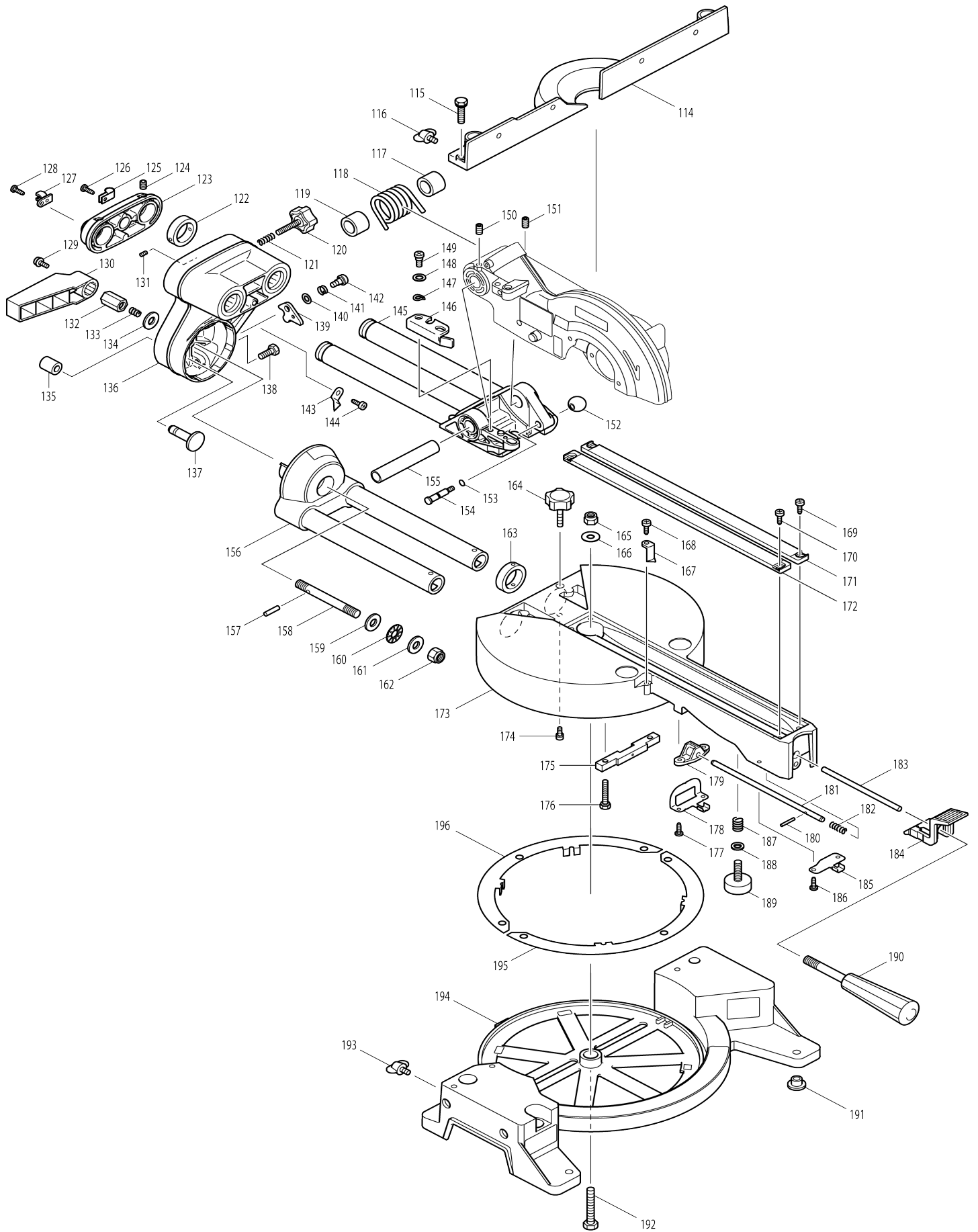

Model No.LS0714 SLIDE COMPOUND SAW 190MM

Item No.	Parts No.	Description	Interchangeability	Q'ty	New/Old	Note1	Note2
001	911228-4	PAN HEAD SCREW M5X18		1	*		
001-1	265491-4	H.S. BUTTON HEAD BOLT M5X16	<	1			
002	267136-0	FLAT WASHER 5		1			
003	418656-9	SAFETY COVER		1	*		
003-1	419224-1	SAFETY COVER	<	1	*		
003-2	419944-7	SAFETY COVER	S	1	*		
003-3	453297-4	SAFETY COVER	<	1	*		
003-4	458785-6	SAFETY COVER	<	1			
004	265008-3	+ FLAT HEAD SCREW M5		1			
005	265461-3	HEX.BOLT M6X18		1	*		
005-1	266733-9	HEX. S.F.H. BOLT M6X16	<	1			
006	224397-5	INNER FLANGE 40		1	*		
006-1	224370-5	INNER FLANGE 40	S	1			
007	285715-2	BEARING RETAINER 55		1			
008	323798-5	SPINDLE		1			
009	211129-9	BALL BEARING 6201DDW		1			
010	317037-3	BEARING BOX		1			
011	213565-5	O RING 42		1			
012	257010-0	RING 12		1			
013	226497-7	HELICAL GEAR 47		1			
014	211021-9	BALL BEARING 607LLB		1			
015	263005-3	RUBBER PIN 6		1			
016	183858-3	BLADE CASE		1	*		
C10	810968-0	CAUTION LABEL		1	*		
C20	817667-5	CAUTION LABEL		1	*		
D10		INC. 15,34,75					
016-1	188248-5	BLADE CASE	<	1	*		
C10	810968-0	CAUTION LABEL		1	*		
C20	817667-5	CAUTION LABEL		1	*		
D10		INC. 15,34,75					
016-2	153951-7	BLADE CASE COMPLETE	O	1			
C10	810968-0	CAUTION LABEL		1			
C20	817667-5	CAUTION LABEL		1			
D10		INC. 15,75					
017	231934-8	SPIRAL SPRING 26		1			
018	344639-2	CENTER WASHER		1	*		
018-1	345589-4	CENTER WASHER	S	1			
019	265473-6	HEX.BOLT M6X14		1	*		
019-1	266732-1	HEX. SOCKET HEAD BOLT M6X16	<	1			
020	344641-5	CENTER COVER		1			
021	345410-7	CENTER PLATE		1	*		
021-1	345585-2	CENTER PLATE	S	1			
022	224282-2	OUTER FLANGE 40		1	*		
022-1	224275-9	OUTER FLANGE 40	S	1			
023	911223-4	PAN HEAD SCREW M5X16		2			
024	922331-6	HEX. SOCKET HEAD BOLT M6X20		1			
025	253804-1	FLAT WASHER 6		1			

026	257163-5	RING 6		1		
027	345411-5	LINK PLATE		1	*	
027-1	154643-1	LINK PLATE COMPLETE	S	1		
028	257163-5	RING 6		1		
029	253804-1	FLAT WASHER 6		1		
030	961018-5	STOP RING E-5		1		
031	266061-2	TAPPING SCREW BIND CT 4X8		1		
032	213460-9	O RING 35		1		
033	416133-5	DUST NOZZLE		1	*	
033-1	419277-0	DUST NOZZLE	O	1		
034	819063-3	MAKITA LABEL		1	*	
034-1	819197-2	MAKITA LOGO LABEL	<	1	*	
035	265381-1	HEX. BOLT M6X16		1	*	
035-1	266757-5	HEX. SOCKET HEAD BOLT M6X16	<	1		
036	262001-8	URETHANE RING 5		1	*	
036-1	262190-9	URETHANE RING 5	<	1		
037	265717-4	SCREW M6X43		1		
038	345438-5	GUARD PLATE		1	*	
038-1	165414-1	GUARD PLATE COMPLETE	S	1		
039	911113-1	PAN HEAD SCREW M4X10 WITH WR		1		
040	423333-0	GUARD		1	*	
040-1	421626-9	GUARD	S	1		
062	324455-8	LOCK PIN		1		
063	418655-1	ROD HOLDER		1		
064	266034-5	TAPPING SCREW CT 4X16		2		
065	231316-4	COMPRESSION SPRING 7		1		
066	324456-6	ROD 8		1		
067	421589-9	CAP		1		
068	345437-7	LOCK LEVER		1	*	
068-1	345807-0	LOCK LEVER	S	1		
069	911113-1	PAN HEAD SCREW M4X10 WITH WR		2		
070	345436-9	LOCK PLATE		1		
071	911113-1	PAN HEAD SCREW M4X10 WITH WR		2		
072	266046-8	TAPPING SCREW 5X50		2		
073	263002-9	RUBBER PIN 4		1		
074	211101-1	BALL BEARING 6001LLB		1		
075	263002-9	RUBBER PIN 4		1		
076	233092-6	COMPRESSION SPRING 5		1		
077	344642-3	SHAFT LOCK		1		
078	240030-1	FAN 70		1		
079	510061-7	ARMATURE ASS'Y 220V		1		
D10		INC. 74,78,80,81				
080	681644-1	INSULATION WASHER		1		
081	211031-6	BALL BEARING 608LLB		1		
082	261110-0	URETHANE WASHER 18		1		
083	416537-1	BAFFLE PLATE		1		
084	634353-1	FIELD 220V		1	*	
084-1	634558-3	FIELD 220V	S	1	*	
084-2	594558-4	FIELD ASS'Y 220V	<	1		

C10	654020-2	RING TERMINAL		2		
C20	654485-8	PARALLEL SPLICE		2		
085	638360-6	SUPPORT COMPLETE		1	*	
086	183183-2	HANDLE SET		1	*	
C10	810966-4	CAUTION LABEL		1	*	
D10		INC. 109				
086-1	188113-8	HANDLE SET	O	1		
C10	810966-4	CAUTION LABEL		1		
D10		INC. 109				
087	665870-0	POWER SUPPLY CORD 1.0-2-3.3		1		
088	682540-6	CORD GUARD 9.3-90		1		
089	687052-4	STRAIN RELIEF		1	*	
089-1	687124-5	STRAIN RELIEF	O	1		
090	265995-6	TAPPING SCREW 4X18		2		
091	151900-8	MOTOR HOUSING COMPLETE		1		
C10	643708-9	BRUSH HOLDER 5-11		2		
C20	810964-8	CAUTION LABEL		1		
D10		INC. 73				
092	416538-9	UPPER COVER		1		
093	911273-9	PAN HEAD SCREW M5X50		3		
094	191963-2	CARBON BRUSH CB-303		1		
095	643750-0	BRUSH HOLDER CAP 7-11		2	*	
095-1	643515-0	HOLDER CAP 7-11	O	2		
096	860820-2	NAME PLATE LS0714		1	*	
096-1	862821-6	NAME PLATE LS0714	<	1		
097	651922-3	SWITCH TG71B		1		
098	645105-5	NOISE SUPPRESSOR		1		
099	416534-7	SWITCH LEVER		1	*	
099-1	452130-7	SWITCH LEVER	<	1		
102	256098-7	PIN 5		1		
103	416533-9	LOCK OFF LEVER		1		
104	231026-3	COMPRESSION SPRING 4		1		
105	911273-9	PAN HEAD SCREW M5X50		3		
107	411478-6	SWITCH BUTTON		1	*	
107-1	417113-4	SWITCH BUTTON	<	1		
109	183183-2	HANDLE SET		1	*	
C10	810966-4	CAUTION LABEL		1	*	
D10		INC. 86				
109-1	188113-8	HANDLE SET	O	1		
C10	810966-4	CAUTION LABEL		1		
D10		INC. 86				
110	265995-6	TAPPING SCREW 4X18		5		
114	317039-9	GUIDE FENCE		1	*	
114-1	317948-2	GUIDE FENCE	S	1	*	
114-2	319191-9	GUIDE FENCE	<	1		
114A_	317039-9	GUIDE FENCE		1		
115	265489-1	HEX. BOLT M6X25		3	*	
115-1	922344-7	H.S.H.BOLT M6X25 WITH WG	<	3		
116	251887-5	SCREW M6X10		1		
117	416535-5	SLEEVE 17		1		
118	231638-2	TORSION SPRING 28		1		
119	416535-5	SLEEVE 17		1		

120	251897-2	SCREW M6X33		1		
121	231325-3	COMPRESSION SPRING 6		1		
122	257214-4	RING 26		1		
123	317617-5	PIPE HOLDER		1		
124	266208-8	H.S.SET SCREW(CUP POINT)M6X8		2		
125	687042-7	STRAIN RELIEF		1		
126	266026-4	TAPPING SCREW BIND CT 4X12		1		
127	416536-3	WRENCH HOLDER		1	*	
127-1	687045-1	STRAIN RELIEF	X	1		
128	266026-4	TAPPING SCREW BIND CT 4X12		1	*	
129	911113-1	PAN HEAD SCREW M4X10 WITH WR		1		
130	416006-2	LEVER 100		1		
131	913106-4	SET SCREW M4X8		1		
132	252144-4	HEX. NUT M10-17		1		
133	231266-3	COMPRESSION SPRING 5		1		
134	253024-7	FLAT WASHER 10		1		
135	286236-7	CAP 16		1		
136	153463-0	ARM COMPLETE		1		
137	324295-4	RELEASE PIN		1		
138	265381-1	HEX. BOLT M6X16		2	*	
138-1	266757-5	HEX. SOCKET HEAD BOLT M6X16	<	2		
139	345299-3	STOPPER PLATE		1		
140	253726-5	FLAT WASHER 6		1		
141	231663-3	TORSION SPRING 8		1		
142	265113-6	+PAN HEAD SCREW M5		1		
143	343678-9	POINTER		1		
144	266026-4	TAPPING SCREW BIND CT 4X12		1		
145	153462-2	FRONT ARM COMPLETE		1		
146	344643-1	STOPPER ARM		1		
147	253948-7	WAVE WASHER 8		1		
148	253835-0	FLAT WASHER 8		1		
149	251267-5	+ PAN HEAD SCREW M6		1		
150	251961-9	H.S.SET SCREW(FLAT POINT)M6X 10		1		
151	251961-9	H.S.SET SCREW(FLAT POINT)M6X 10		1		
152	271601-3	KNOB 20		1		
153	213021-5	O RING 5		1		
154	324183-5	STOPPER PIN		1		
155	331350-5	PIN 16-90		1	*	
155-1	331350-5	PIN 16-90	O	1		
156	153482-6	ARM HOLDER COMPLETE		1		
C10	816392-5	BEVEL SCALE LABEL		1		
157	256100-6	PIN 5		1		
158	266320-4	SCREW M10		1		
159	253024-7	FLAT WASHER 10		1		
160	216413-7	THRUST NEEDLE CAGE 1024		1		
161	253024-7	FLAT WASHER 10		1		
162	252130-5	HEX. LOCK NUT M10-17		1		
163	257214-4	RING 26		1		
164	251897-2	SCREW M6X33		1		

165	252105-4	HEX. LOCK NUT M8-13		1		
166	253731-2	FLAT WASHER 8		1		
167	416355-7	INDICATION PLATE		1		
168	266026-4	TAPPING SCREW BIND CT 4X12		1		
169	266026-4	TAPPING SCREW BIND CT 4X12		2		
170	266026-4	TAPPING SCREW BIND CT 4X12		2		
171	417993-8	KERF BOARD		1		
172	417993-8	KERF BOARD		1		
173	153464-8	TURN BASE COMPLETE		1	*	
C10	211376-2	LINEAR BALL BEARING 2560		2	*	
C20	262077-5	FELT RING 25		4	*	
C30	263005-3	RUBBER PIN 6		1	*	
C40	344638-4	CAP 35		2	*	
C50	817283-3	CAUTION LABEL		2	*	
173-1	154659-6	TURN BASE COMPLETE	S	1	*	
C10	211376-2	LINEAR BALL BEARING 2560		2	*	
C20	262077-5	FELT RING 25		4	*	
C30	263005-3	RUBBER PIN 6		1	*	
C40	344638-4	CAP 35		2	*	
C50	817283-3	CAUTION LABEL		2	*	
173-2	140H16-2	TURN BASE COMPLETE	<	1		
C10	211376-2	LINEAR BALL BEARING 2560		2		
C20	262077-5	FELT RING 25		4		
C30	263005-3	RUBBER PIN 6		1		
C40	344638-4	CAP 35		2		
C50	813L22-1	CAUTION LABEL	<	2		
174	922111-0	HEX. SOCKET HEAD BOLT M4X10		1		
175	153580-6	SQUARE ROD COMPLETE		1		
C10	263005-3	RUBBER PIN 6		1		
176	925251-3	HEX.BOLT M5X30		2		
177	266034-5	TAPPING SCREW CT 4X16		2		
178	344601-7	LOCK PLATE		1		
179	317616-7	PIN HOLDER		1		
180	256158-5	PIN 3		1		
181	324288-1	LOCK PIN		1		
182	231325-3	COMPRESSION SPRING 6		1		
183	324289-9	ROD 6		1		
184	416450-3	LOCK LEVER		1		
185	345272-3	LOCK LEVER PLATE		1		
186	266034-5	TAPPING SCREW CT 4X16		2		
187	231418-6	COMPRESSION SPRING 9		1		
188	253731-2	FLAT WASHER 8		1		
189	266296-5	ADJUST BOLT M8X27		1	*	
189-1	266432-3	ADJUST BOLT M8X27	O	1		
190	273515-2	GRIP 32		1		
191	286212-1	CAP 20		5		
192	921472-5	HEX. BOLT M8X50		1		
193	251887-5	SCREW M6X10		2	*	
193-1	911318-3	P.H.SCREW M6X14 WITH WR	<	2		
194	153949-4	BASE COMPLETE		1		
C10	816339-9	MITER SCALE PLATE		1		
C20	810965-6	CAUTION LABEL		1		

195	344646-5	SLIDE PLATE		1		
196	344646-5	SLIDE PLATE		1		
197	231690-0	TORSION SPRING 8		1		
198	911114-9	PAN HEAD SCREW M4X10		1		
199	345649-2	GUARD		1	*	
199-1	346550-4	GUARD	<	1		
A01	122523-9	DUST BAG ASS'Y		1	*	
C10	410602-8	FASTENER		1	*	
A01-1	122852-0	DUST BAG ASS'Y	O	1		
C10	410602-8	FASTENER		1		
A02	122571-8	VICE ASS'Y		1		
C10	316938-2	WISE ARM		1		
C20	251887-5	SCREW M6X10		1		
C30	322313-2	WISE ROD		1		
C40	265733-6	THUMB SCREW M10X60		1		
C50	253804-1	FLAT WASHER 6		1		
C60	343651-9	WISE PLATE		1		
C70	251370-2	+ PAN HEAD SCREW M5		1		
A03	411478-6	SWITCH BUTTON		2	*	
A04	762001-3	TRIANGULAR RULE		1		
A05	322312-4	HOLDER		2		
A06	B-03866	T.C.T.SAW BLADE 190X20X24		1	*	
A06-1	B-03850	T.C.T.SAW BLADE 190X20X24	<	1		
A07	782223-9	SOCKET WRENCH		1	*	
A07-1	783203-8	HEX. WRENCH 5	X	1		
E03	345808-8	SUB LEVER		1		
E04	911113-1	PAN HEAD SCREW M4X10 WITH WR		2		
E05	135466-6	GUARD ASS'Y		1	*	
D10		INC. 38,40,197,198,199				
E05-1	135511-7	GUARD ASS'Y	<	1		
D10		INC. 38,40,197,198,199				
E07	142810-0	SUB FENCE COMPLETE		1		
E08	252014-7	HEX. LOCK NUT M6-10		1		
E09	266061-2	TAPPING SCREW BIND CT 4X8		1		
E10	345359-1	SUB FENCE PLATE		1		
E11	912357-6	COUNTERSUNK HEAD SCREW M6 X35		1		
E12	253804-1	FLAT WASHER 6		1		
F05-1	198688-9	STAND SET	<	1		
003-3	458785-6	SAFETY COVER		1		
016-2	153955-9	BLADE CASE COMPLETE		1		
038-1	345438-5	GUARD PLATE		1		
040	424045-8	GUARD		1		
094-1	191963-2	CARBON BRUSH CB-303		1		
096-1	855G82-7	LS0714 NAME PLATE		1		
099	452130-7	SWITCH LEVER		1		
107	417113-4	SWITCH BUTTON		1		
173-1	140H16-2	TURN BASE COMPLETE		1		
C50	813L22-1	CAUTION LABEL		2		
193	911318-3	P.H.SCREW M6X14 WITH WR		2		
A06-1	B-03866	T.C.T.SAW BLADE 190X20X24		1	*	

A06-2	B-03850	T.C.T.SAW BLADE 190X20X24	<	1		
A09	127056-9	HOLDER ASSEMBLY		2		
C10	265785-7	THUMB SCREW M5X10		4		
C20	265917-6	ADJUST BOLT M8X42		4		

Please state Parts No. when your order.

Print Date 26.10.2023