

# Model No.LS1013L SLIDE COMPOUND SAW 255MM

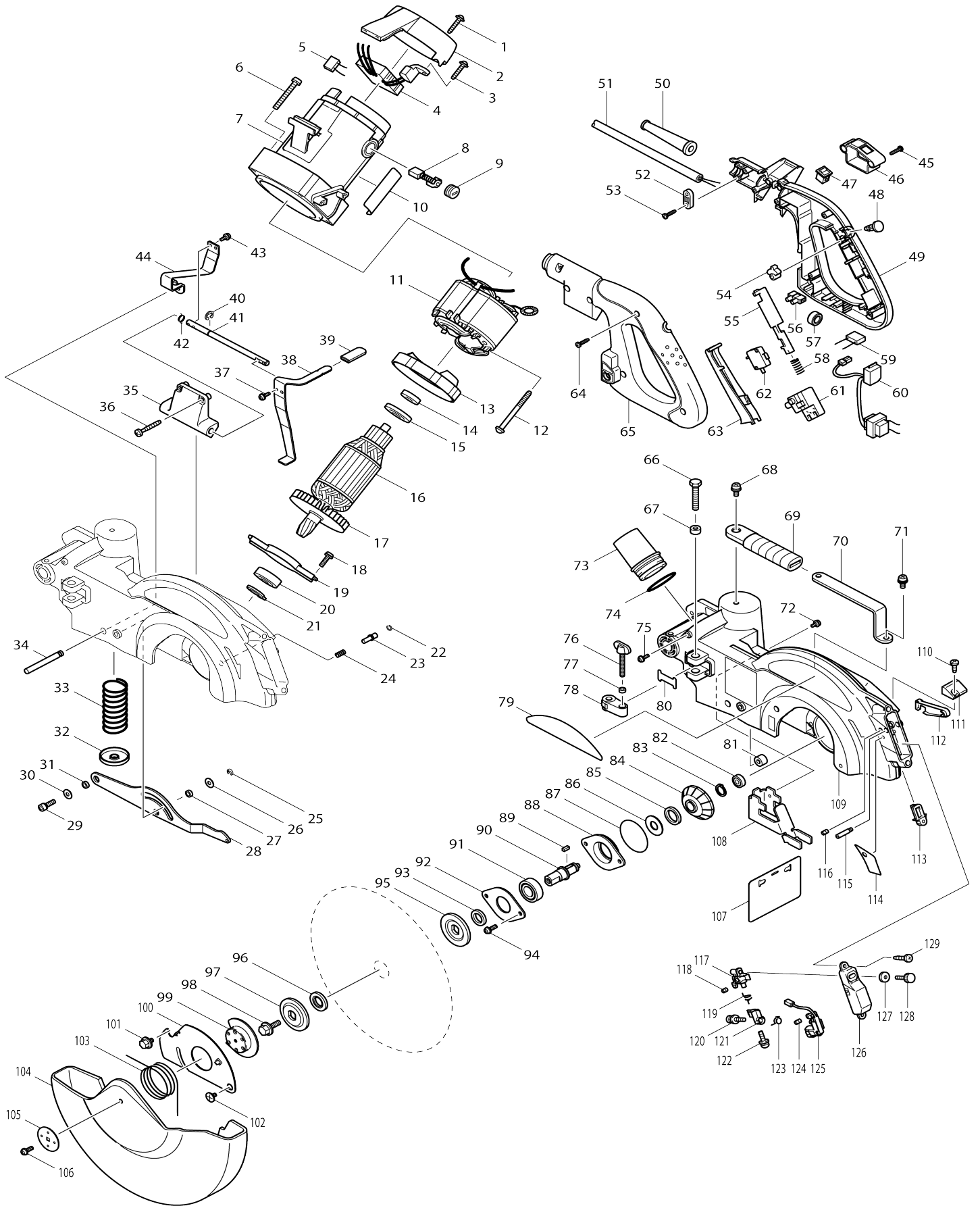

# Model No.LS1013L SLIDE COMPOUND SAW 255MM

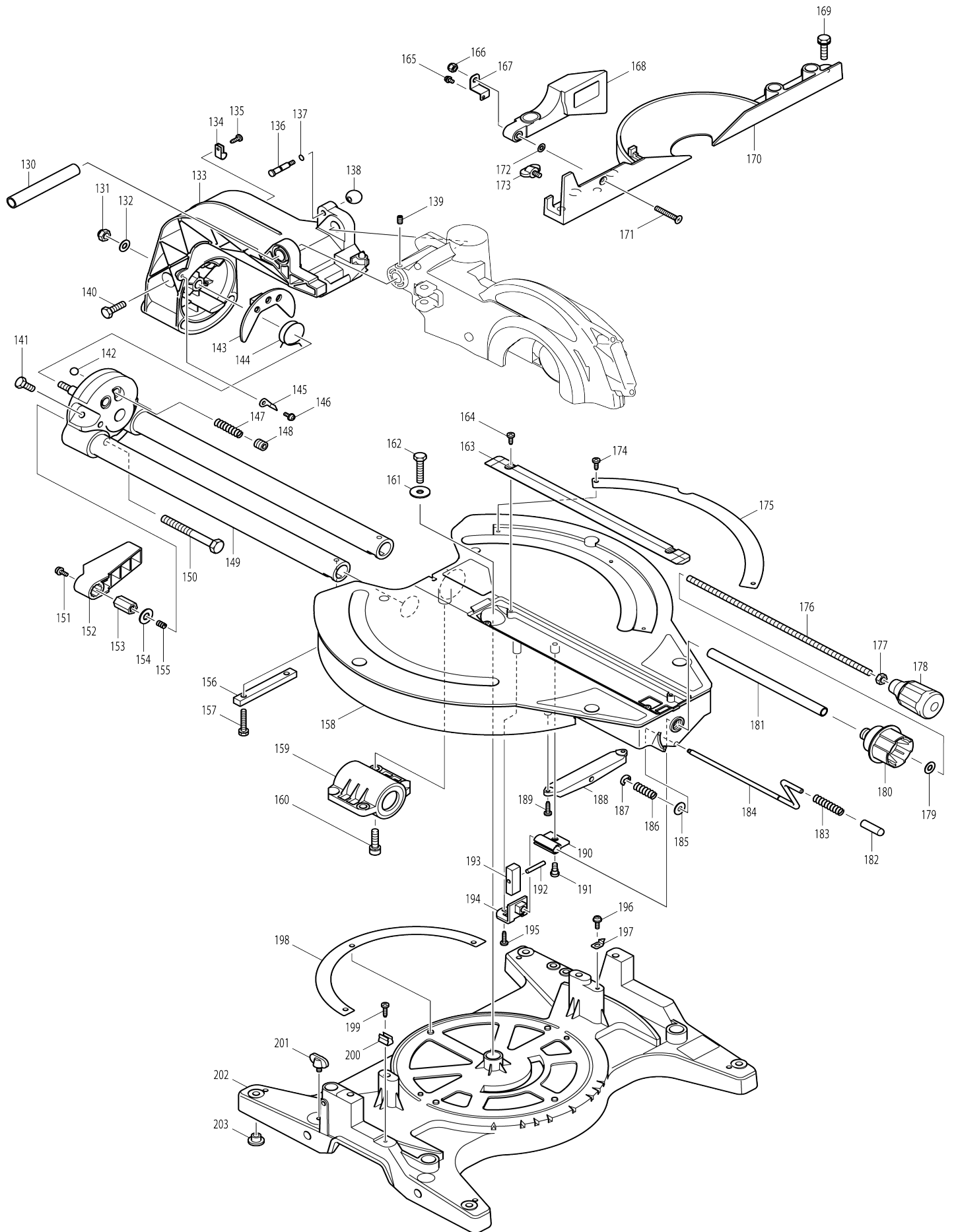

Model No.LS1013L SLIDE COMPOUND SAW 255MM

Item No.	Parts No.	Description	Interchangeability	Q'ty	New/Old	Note1	Note2
001	265995-6	TAPPING SCREW 4X18		2			
002	416075-3	REAR COVER		1			
003	265995-6	TAPPING SCREW 4X18		1			
004	631219-6	CONTROLLER		1			
005	645006-7	NOISE SUPPRESSOR		1	*		
005-1	645185-1	NOISE SUPPRESSOR	O	1			
006	911373-5	PAN HEAD SCREW M6X50		4			
007	154718-6	MOTOR HOUSING COMPLETE		1			
C10	643660-1	BRUSH HOLDER 6.5-13.5		2			
C20	810966-4	CAUTION LABEL		1			
C30	817320-3	CAUTION LABEL		1			
008	181044-0	CARBON BRUSH CB-153		1	*		
008-1	194985-1	CARBON BRUSH SET CB-153	O	1			
009	643650-4	BRUSH HOLDER CAP 6.5-13.5		2	*		
009-1	643650-4	BRUSH HOLDER CAP 6.5-13.5	O	2			
010	861577-8	LS1013L NAME PLATE		1			
011	599506-8	FIELD ASS'Y 220V		1			
C10	654020-2	RING TERMINAL		2			
C20	654502-4	CONNECTOR P-2		2			
012	266029-8	TAPPING SCREW 5X65		2			
013	416107-6	BAFFLE PLATE		1			
014	211061-7	BALL BEARING 6000LLB		1			
015	681642-5	INSULATION WASHER		1			
016	516928-7	ARMATURE ASS'Y 220V		1			
D10		INC. 14,15,17					
017	240001-8	FAN 80		1			
018	911223-4	PAN HEAD SCREW M5X16		2			
019	285686-3	BEARING RETAINER 94		1			
020	211275-8	BALL BEARING 6003DDW		1			
021	961057-5	RETAINING RING S-17		1			
022	231928-3	RING SPRING 8		1			
023	256633-1	PIN 6		1			
024	231240-1	COMPRESSION SPRING 7		1			
025	961018-5	STOP RING E-5		1			
026	253804-1	FLAT WASHER 6		1			
027	257163-5	RING 6		1			
028	345604-4	LINK PLATE		1			
029	922331-6	HEX. SOCKET HEAD BOLT M6X20		1			
030	253804-1	FLAT WASHER 6		1			
031	257163-5	RING 6		1			
032	344464-1	SPRING HOLDER		1			
033	233461-1	COMPRESSION SPRING 28		1			
034	324609-7	LOCK PIN 8		1			
035	419075-2	ROD HOLDER		1			
036	266050-7	TAPPING SCREW 4X30		2			
037	911113-1	PAN HEAD SCREW M4X10 WITH WR		2	*		
037-1	922107-1	HEX. SOCKET HEAD BOLT M4X8	<	2			

038	345606-0	LOCK LEVER		1	*		
038-1	345828-2	LOCK LEVER	<	1			
039	421589-9	CAP		1			
040	961012-7	STOP RING E-6		2			
041	324608-9	ROD 8		1			
042	231633-2	TORSION SPRING 8		1			
043	911113-1	PAN HEAD SCREW M4X10 WITH WR		2			
044	345608-6	LOCK PLATE		1			
045	265995-6	TAPPING SCREW 4X18		2			
046	154541-9	SWITCH BOX COMPLETE		1			
C10	817540-9	LASER BEAM LABEL		1			
047	651522-9	SWITCH SLE6A		1			
048	411478-6	SWITCH BUTTON		1			
049	183980-6	HANDLE SET		1			
D10		INC. 65					
050	682540-6	CORD GUARD 9.3-90		1			
051	665865-3	POWER SUPPLY CORD 1.0-2-2.5		1			
052	687052-4	STRAIN RELIEF		1			
053	265995-6	TAPPING SCREW 4X18		2			
054	414546-4	CAM		1			
055	416000-4	LOCK OFF LEVER		1			
056	654575-7	TERMINAL BLOCK		1			
057	688131-1	LINE FILTER		1	*		
057-1	688131-1	LINE FILTER	O	1			
058	231457-6	COMPRESSION SPRING 3		1			
059	645105-5	NOISE SUPPRESSOR		1	*		
059-1	645185-1	NOISE SUPPRESSOR	O	1			
060	631617-4	POWER SUPPLY CIRCUIT		1			
061	651923-1	SWITCH TG70B		1			
062	651941-9	SWITCH V-15-2A5		1			
063	415999-0	SWITCH LEVER		1			
064	265995-6	TAPPING SCREW 4X18		6			
065	183980-6	HANDLE SET		1			
D10		INC. 49					
066	921467-8	HEX. BOLT M8X45		1			
067	262003-4	RUBBER RING 6		1			
068	911323-0	PAN HEAD SCREW M6X16		1			
069	421562-9	GRIP		1			
070	344420-1	GRIP HOLDER		1			
071	911323-0	PAN HEAD SCREW M6X16		1			
072	911114-9	PAN HEAD SCREW M4X10		1			
073	419277-0	DUST NOZZLE		1			
074	213460-9	O RING 35		1			
075	911113-1	PAN HEAD SCREW M4X10 WITH WR		1			
076	265717-4	SCREW M6X43		1			
077	262001-8	URETHANE RING 5		1			
078	317176-9	STOPPER ARM		1			
079	819214-8	MAKITA LOGO LABEL		1			
080	344045-1	STOPPER ARM PLATE		1			
081	421952-6	CUSHION		1			

082	211021-9	BALL BEARING 607LLB		1		
083	961054-1	RETAINING RING S-14		1		
084	226742-0	SPIRAL BEVEL GEAR 33		1		
085	262074-1	RUBBER RING 20		1		
086	267035-6	FLAT WASHER 14		1		
087	213673-2	O RING 52		1		
088	316836-0	BEARING BOX (A)		1		
089	254202-2	KEY 4		1		
090	322899-6	SPINDLE		1		
091	211275-8	BALL BEARING 6003DDW		1		
092	285828-9	BEARING RETAINER 66		1		
093	257022-3	RING 16		1		
094	911223-4	PAN HEAD SCREW M5X16		2		
095	224333-1	FLANGE 53		1		
096	257262-3	RING 16		1		
097	224333-1	FLANGE 53		1		
098	265355-2	HEX. FLANGE HEAD BOLT M8X20		1		
099	344473-0	CENTER PLATE		1		
100	345603-6	CENTER COVER		1		
101	265324-3	HEX. FLANGE HEAD BOLT M8X12		1		
102	265008-3	+ FLAT HEAD SCREW M5		1		
103	231613-8	TORSION SPRING 45		1		
104	419073-6	SAFETY COVER		1		
105	253977-0	FLAT WASHER 6		1		
106	911218-7	PAN HEAD SCREW M5X14		1		
107	421916-0	GUARD		1		
108	345610-9	GUARD PLATE		1		
109	188020-5	BLADE CASE SET		1		
C10	810064-4	LASER BEAM CAUTION LABEL		1		
C20	810968-0	CAUTION LABEL		1		
C30	816847-0	OPERATIONAL INDICATION LABEL		1		
C40	810354-5	LASER BEAM LABEL		1		
D10		INC. 79				
110	266026-4	TAPPING SCREW BIND CT 4X12		1		
111	419078-6	LEAD COVER HOLDER		1		
112	419076-0	LEAD COVER		1		
113	418104-8	LENS		1		
114	801262-1	LASER LABEL		1	*	
114-1	804293-9	LASER LABEL	S	1		
115	266306-8	SHOULDER SCREW M5		1		
116	266229-0	H.S.SET SCREW(CUP POINT)M5X8		2		
117	418107-2	BLOCK C		1	*	
117-1	419379-2	BLOCK C	S	1		
118	266318-1	H.S.SET SCREW(FLAT POINT)M4X6		1		
119	231664-1	TORSION SPRING 9		1		
120	911014-3	PAN HEAD SCREW M3X10		1	*	
120-1	911003-8	PAN HEAD SCREW M3X6	S	1		
121	418106-4	BLOCK B		1	*	
121-1	419378-4	BLOCK B	S	1		
122	911014-3	PAN HEAD SCREW M3X10		1	*	

122-1	911003-8	PAN HEAD SCREW M3X6	S	1		
123	231664-1	TORSION SPRING 9		1		
124	266318-1	H.S.SET SCREW(FLAT POINT)M4X6		1		
125	638356-7	LASER CIRCUIT COMPLETE		1	*	
125-1	638442-4	LASER CIRCUIT COMPLETE	S	1		
126	418108-0	TOP COVER		1	*	
126-1	419380-7	TOP COVER	S	1		
127	253807-5	FLAT WASHER 5		1		
128	265753-0	THUMB SCREW M5X24		1		
129	266042-6	TAPPING SCREW BIND CT 4X20		2		
130	331428-4	PIN 16-113		1	*	
130-1	331428-4	PIN 16-113	O	1		
131	252105-4	HEX. LOCK NUT M8-13		1		
132	941201-0	FLAT WASHER 8		1		
133	317983-0	ARM		1		
134	687042-7	STRAIN RELIEF		1		
135	266026-4	TAPPING SCREW BIND CT 4X12		1		
136	324183-5	STOPPER PIN		1		
137	213021-5	O RING 5		1		
138	271601-3	KNOB 20		1		
139	251961-9	H.S.SET SCREW(FLAT POINT)M6X10		1		
140	265455-8	HEX. BOLT M8X28		2		
141	265412-6	HEX. BOLT M8X20		2		
142	216003-6	STEEL BALL 10		2		
143	345418-1	GUIDE PLATE		1		
144	231626-9	TORSION SPRING 28		1		
145	413067-3	INDICATION PLATE		2		
146	911114-9	PAN HEAD SCREW M4X10		2		
147	233168-9	COMPRESSION SPRING 5		2		
148	266131-7	H.S.SET SCREW(FLATPOINT)M12X12		2		
149	151459-5	ARM HOLDER COMPLETE		1		
C10	816771-7	BEVEL SCALE LABEL		1		
150	251668-7	HEX. BOLT M10X90		1		
151	911113-1	PAN HEAD SCREW M4X10 WITH WR		1		
152	416006-2	LEVER 100		1		
153	252144-4	HEX. NUT M10-17		1		
154	253024-7	FLAT WASHER 10		1		
155	231266-3	COMPRESSION SPRING 5		1		
156	152542-1	SQUARE ROD COMPLETE		1		
C10	263005-3	RUBBER PIN 6		1		
157	921356-7	HEX. BOLT M6X35		2		
158	153832-5	TURN BASE COMPLETE		1		
C10	211444-1	LINEAR BALL BEARING 3064		1		
C20	219002-7	BEARING 30		1		
C30	262048-2	FELT RING 30		2		
C40	263005-3	RUBBER PIN 6		1		
C50	343676-3	CAP		1		
C60	817283-3	CAUTION LABEL		2		
159	152540-5	BEARING BOX B COMPLETE		1		

C10	211444-1	LINEAR BALL BEARING 3064		1		
C20	262048-2	FELT RING 30		2		
C30	343676-3	CAP		2		
C40	316837-8	BEARING BOX (B)		1		
160	922451-6	HEX. SOCKET HEAD BOLT M8X30		2		
161	253852-0	FLAT WASHER 8		1		
162	265442-7	HEX. BOLT M8X40		1		
163	419222-5	KERF BOARD		2		
164	266026-4	TAPPING SCREW BIND CT 4X12		4		
165	911108-4	PAN HEAD SCREW M4X8		1		
166	252014-7	HEX. LOCK NUT M6-10		1		
167	344463-3	SUB FENCE PLATE		1		
168	154564-7	SUB FENCE COMPLETE		1		
C10	810967-2	CAUTION LABEL		1		
169	265488-3	HEX. BOLT M8X30		4		
170	316840-9	GUIDE RULE		1		
171	912357-6	COUNTERSUNK HEAD SCREW M6 X35		1		
172	253715-0	FLAT WASHER 6		1		
173	251887-5	SCREW M6X10		1		
174	266026-4	TAPPING SCREW BIND CT 4X12		2		
175	816326-8	MITER SCALE PLATE		1		
176	266132-5	SCREW M8X320		1		
177	931402-8	HEX. NUT M8		1		
178	271314-6	GRIP 40		1		
179	941201-0	FLAT WASHER 8		1		
180	152541-3	KNOB 48 COMPLETE		1		
181	331491-7	PIN 9-200		1	*	
181-1	331491-7	PIN 9-200	O	1		
182	421563-7	CAP 10		1		
183	322924-3	COIL SPRING		1		
184	322909-9	LOCK PIN		1		
185	253804-1	FLAT WASHER 6		1		
186	231307-5	COMPRESSION SPRING 6		1		
187	961018-5	STOP RING E-5		1		
188	316899-6	PIN HOLDER		1		
189	266034-5	TAPPING SCREW CT 4X16		2		
190	344411-2	SLIDE STOPPER		1		
191	251267-5	+ PAN HEAD SCREW M6		1		
192	256196-7	PIN 5		1		
193	331493-3	TURN STOPPER		1		
194	344412-0	STOPPER HOLDER		1		
195	266034-5	TAPPING SCREW CT 4X16		1		
196	266026-4	TAPPING SCREW BIND CT 4X12		1		
197	816128-2	POINTER		1		
198	344477-2	SLIDE PLATE		2		
199	266034-5	TAPPING SCREW CT 4X16		1		
200	232075-3	LEAF SPRING		1		
201	251887-5	SCREW M6X10		2		
202	153889-6	BASE COMPLETE		1		
C10	810965-6	CAUTION LABEL		1		
203	286212-1	CAP 20		4		

A01	122523-9	DUST BAG ASS'Y		1	*		
C10	410602-8	FASTENER		1	*		
A01-1	122852-0	DUST BAG ASS'Y	O	1			
C10	410602-8	FASTENER		1			
A02	122538-6	WISE ASS'Y		1			
C10	251370-2	+ PAN HEAD SCREW M5		1			
C20	251887-5	SCREW M6X10		1			
C30	253804-1	FLAT WASHER 6		1			
C40	271309-9	KNOB 40		1			
C50	316898-8	WISE ARM		1			
C60	322983-7	WISE ROD		1			
C70	343651-9	WISE PLATE		1			
A03	153896-9	SUB FENCE R COMPLETE		1			
C10	817319-8	CAUTION LABEL		1			
A04	411478-6	SWITCH BUTTON		2			
A05	762001-3	TRIANGULAR RULE		1			
A06	151917-1	KERF BLOCK COMPLETE		1			
C10	810993-1	CAUTION LABEL		1			
A07	251314-2	+ SCREW M4X12		2			
A08	783208-8	HEX. WRENCH 2.5		1			
A09	251887-5	SCREW M6X10		2			
A10	322932-4	HOLDER 255		2			
A11	A-85014	T.C.T.SAW BLADE 260X60TX30		1	*		
A11-1	B-04597	TCT SAW BLADE 260X30X70T	O	1			
A12	782212-4	SOCKET WRENCH 13		1			
E05	233471-8	COMPRESSION SPRING 6		1			
F02	192628-9	CROWN MOLDING STOPPER (L.R )		1			
F05-1	198688-9	STAND SET	<	1			

Please state Parts No. when your order.

Print Date 12/04/2023