

Model No.LS1040F MITER SAW 255MM

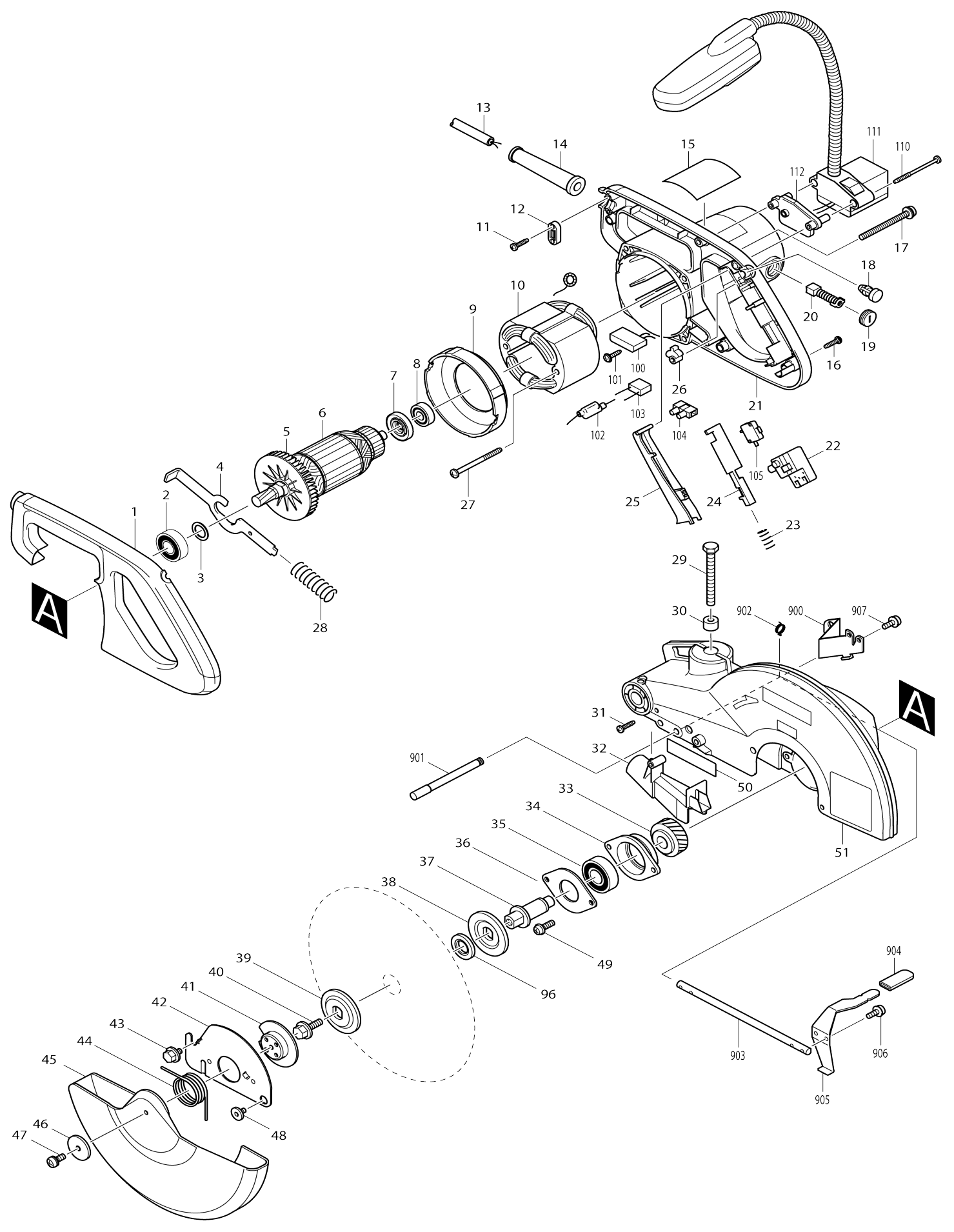

Model No. LS1040F MITER SAW 255MM

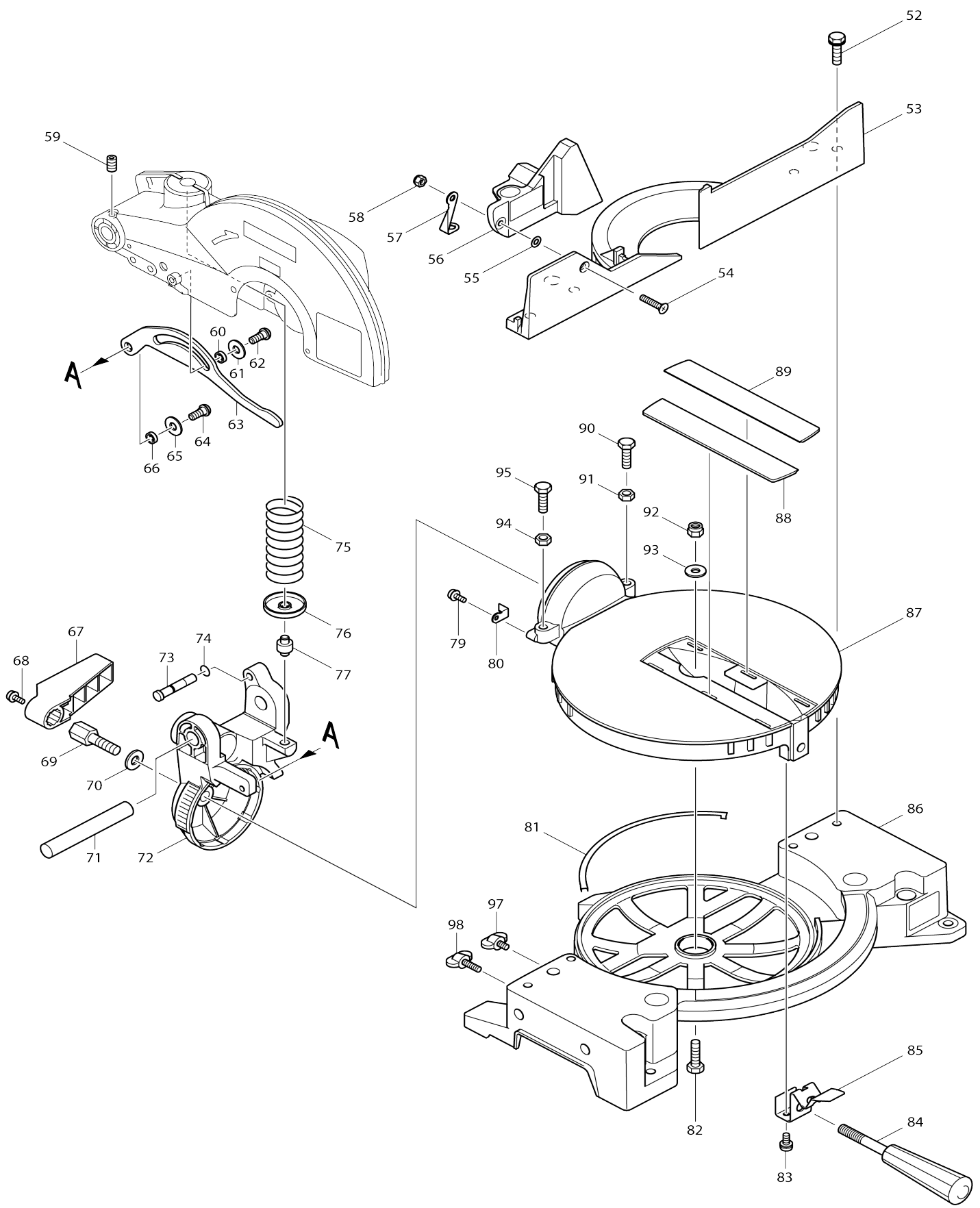

Model No.LS1040F MITER SAW 255MM

Item No.	Parts No.	Description	Interchangability	Q'ty	New/Old	Note1	Note2
001	416004-6	HANDLE COVER		1	*		
001-1	458787-2	HANDLE COVER	<	1			
002	211206-7	BALL BEARING 6202LLB		1			
003	253853-8	FLAT WASHER 15		1	*		
003-1	267280-3	FLAT WASHER 15	<	1			
004	343641-2	SHAFT LOCK		1			
005	241909-9	FAN 80		1			
006	516718-8	ARMATURE ASS'Y 220V		1	*		
D10		INC. 2,3,5,7,8					
006-1	516718-8	ARMATURE ASS'Y 220V	O	1			
D10		INC. 2,3,5,7,8					
007	681640-9	INSULATION WASHER		1	*		
007-1	681640-9	INSULATION WASHER	O	1			
008	211061-7	BALL BEARING 6000LLB		1			
009	416442-2	BAFFLE PLATE		1			
010	526068-3	FIELD ASS'Y 220-240V		1			
C10	654020-2	RING TERMINAL		1			
C20	654502-4	CONNECTOR P-2		1			
011	265995-6	TAPPING SCREW 4X18		2			
012	687052-4	STRAIN RELIEF		1	*		
012-1	687124-5	STRAIN RELIEF	O	1			
013	665865-3	POWER SUPPLY CORD 1.0-2-2.5		1			
014	682540-6	CORD GUARD 9.3-90		1			
015	850407-8	NAME PLATE LS1040F		1			
016	265995-6	TAPPING SCREW 4X18		3			
017	911383-2	PAN HEAD SCREW M6X60		4			
018	411478-6	SWITCH BUTTON		1	*		
018-1	417113-4	SWITCH BUTTON	O	1			
019	643650-4	BRUSH HOLDER CAP 6.5-13.5		2	*		
019-1	643650-4	BRUSH HOLDER CAP 6.5-13.5	O	2			
020	181044-0	CARBON BRUSH CB-153		1			
021	153568-6	MOTOR HOUSING COMPLETE		1	*		
C10	817881-3	CAUTION LABEL		1	*		
C20	643660-1	BRUSH HOLDER 6.5-13.5		2	*		
021-1	153798-9	MOTOR HOUSING COMPLETE	<	1	*		
C10	817881-3	CAUTION LABEL		1	*		
C20	643660-1	BRUSH HOLDER 6.5-13.5		2	*		
021-2	154562-1	MOTOR HOUSING COMPLETE	<	1			
C10	810964-8	CAUTION LABEL		1			
C20	643660-1	BRUSH HOLDER 6.5-13.5		2	*		
C21	643653-8	BRUSH HOLDER 6.5-13.5	O	2	*		
C22	643536-2	BRUSH HOLDER 6.5X13.5	<	2			
022	651923-1	SWITCH TG70B		1			
023	231457-6	COMPRESSION SPRING 3		1			
024	416000-4	LOCK OFF LEVER		1			
025	415999-0	SWITCH LEVER		1	*		
025-1	459017-4	SWITCH LEVER	<	1			

026	414546-4	CAM		1		
027	266029-8	TAPPING SCREW 5X65		2		
028	231297-2	COMPRESSION SPRING 9		1		
029	251667-9	HEX. BOLT M8X75		1		
030	262511-5	RUBBER SLEEVE 6		1		
031	265995-6	TAPPING SCREW 4X18		1		
032	416007-0	GUIDE COVER		1	*	
032-1	453695-2	GUIDE COVER	<	1		
033	226465-0	HELICAL GEAR 42		1		
034	316821-3	BEARING BOX		1		
035	211256-2	BALL BEARING 6203LLB		1		
036	285685-5	BEARING RETAINER 64		1		
037	322865-3	SPINDLE		1		
038	224333-1	FLANGE 53		1		
039	224333-1	FLANGE 53		1		
040	265355-2	HEX. FLANGE HEAD BOLT M8X20		1		
041	343639-9	CENTER PLATE		1		
042	344380-7	CENTER COVER		1		
043	265324-3	HEX. FLANGE HEAD BOLT M8X12		1		
044	231593-8	TORSION SPRING 36		1		
045	416003-8	SAFETY COVER		1		
046	267136-0	FLAT WASHER 5		1		
047	911213-7	PAN HEAD SCREW M5X12		1	*	
047-1	922211-6	H.S.H.BOLT M5X12 WITH W	<	1		
048	265985-9	HEX.SOCKET HEAD BOLT M6		1		
049	911223-4	PAN HEAD SCREW M5X16		2		
050	819064-1	MAKITA MARK		1	*	
050-1	819214-8	MAKITA LOGO LABEL	X	1	*	
051	151489-6	BLADE CASE COMPLETE		1	*	
C10	817667-5	CAUTION LABEL		1	*	
C20	817874-0	CAUTION LABEL		1	*	
C30	263005-3	RUBBER PIN 6		1	*	
051-1	151489-6	BLADE CASE COMPLETE	O	1	*	
C10	817667-5	CAUTION LABEL		1	*	
C20	817874-0	CAUTION LABEL		1	*	
C30	263005-3	RUBBER PIN 6		1	*	
051-2	154560-5	BLADE CASE COMPLETE	<	1	*	
C10	817667-5	CAUTION LABEL		1	*	
C20	810968-0	CAUTION LABEL		1	*	
C30	263005-3	RUBBER PIN 6		1	*	
051-3	188330-0	BLADE CASE SET	O	1	*	
C10	817667-5	CAUTION LABEL		1	*	
C20	810968-0	CAUTION LABEL		1	*	
C30	263005-3	RUBBER PIN 6		1	*	
D10		INC.50				
051-4	188330-0	BLADE CASE SET	O	1	*	
C10	816847-0	OPERATIONAL INDICATION LABEL	<	1	*	
C20	810968-0	CAUTION LABEL		1	*	
C30	263005-3	RUBBER PIN 6		1	*	
D10		INC.50				
051-5	140655-0	BLADE CASE COMPLETE	O	1	*	

C10	816847-0	OPERATIONAL INDICATION LABEL		1	*		
C20	810968-0	CAUTION LABEL		1	*		
C30	263005-3	RUBBER PIN 6		1	*		
051-6	141570-1	BLADE CASE COMPLETE	S	1			
C10	816847-0	OPERATIONAL INDICATION LABEL		1			
C20	810968-0	CAUTION LABEL		1			
C30	263005-3	RUBBER PIN 6		1			
052	265488-3	HEX. BOLT M8X30		4			
053	316826-3	GUIDE RULE		1	*		
053-1	316826-3	GUIDE RULE	O	1	*		
053-2	318847-1	GUIDE RULE	<	1			
054	912342-9	COUNTERSUNK HEAD SCREW M6 X25		1			
055	253715-0	FLAT WASHER 6		1			
056	150663-3	SUB FENCE COMPLETE		1	*		
C10	810858-7	CAUTION LABEL		1	*		
056-1	150663-3	SUB FENCE COMPLETE	O	1	*		
C10	810858-7	CAUTION LABEL		1	*		
056-2	154559-0	SUB FENCE COMPLETE	<	1	*		
C10	810967-2	CAUTION LABEL		1	*		
056-3	142816-8	SUB FENCE COMPLETE	<	1			
C10	810967-2	CAUTION LABEL		1			
057	344476-4	SUB FENCE PLATE		1			
058	252014-7	HEX. LOCK NUT M6-10		1			
059	251961-9	H.S.SET SCREW(FLAT POINT)M6X 10		1			
060	257162-7	RING 7		1			
061	253823-7	FLAT WASHER 7		1			
062	265984-1	HEX.SOCKET BUTTON HEAD BOLT M6		1			
063	344377-6	LINK PLATE		1			
064	265984-1	HEX.SOCKET BUTTON HEAD BOLT M6		1			
065	253823-7	FLAT WASHER 7		1			
066	257162-7	RING 7		1			
067	416006-2	LEVER 100		1			
068	911113-1	PAN HEAD SCREW M4X10 WITH WR		1			
069	265437-0	HEX. BOLT M10		1			
070	253024-7	FLAT WASHER 10		1			
071	256836-7	ROD 16		1			
072	150664-1	ARM COMPLETE		1	*		
C10	816310-3	SCALE LABEL		1	*		
072-1	150664-1	ARM COMPLETE	O	1	*		
C10	816310-3	SCALE LABEL		1	*		
072-2	154463-3	ARM COMPLETE	O	1			
C10	816310-3	SCALE LABEL		1			
073	322317-4	STOPPER PIN		1			
074	213021-5	O RING 5		1			
075	233152-4	COMPRESSION SPRING 28		1			
076	344464-1	SPRING HOLDER		1			
077	256280-8	PIN 8		1			

079	911113-1	PAN HEAD SCREW M4X10 WITH WR		1		
080	344385-7	POINTER		1		
081	343799-7	SLIDE PLATE		3		
082	921452-1	HEX. BOLT M8X30		1		
083	911213-7	PAN HEAD SCREW M5X12		2		
084	273495-2	GRIP 32		1		
085	344381-5	KNOCK SPRING		1		
086	150648-9	BASE COMPLETE		1	*	
C10	816311-1	MITER SCALE PLATE		1	*	
C20	817838-4	CAUTION LABEL		1	*	
C30	817283-3	CAUTION LABEL		2	*	
086-1	150648-9	BASE COMPLETE	O	1	*	
C10	816311-1	MITER SCALE PLATE		1	*	
C20	817838-4	CAUTION LABEL		1	*	
C30	817283-3	CAUTION LABEL		2	*	
086-2	154558-2	BASE COMPLETE	<	1		
C10	816311-1	MITER SCALE PLATE		1		
C20	810965-6	CAUTION LABEL		1		
C30	817283-3	CAUTION LABEL		2		
087	316824-7	TURN BASE		1	*	
087-1	316824-7	TURN BASE	O	1		
088	416001-2	KERF BOARD		1		
089	416001-2	KERF BOARD		1		
090	921452-1	HEX. BOLT M8X30		1		
091	931402-8	HEX. NUT M8		1		
092	252105-4	HEX. LOCK NUT M8-13		1		
093	253762-1	FLAT WASHER 8		1		
094	931402-8	HEX. NUT M8		1		
095	921452-1	HEX. BOLT M8X30		1		
096	257137-6	RING 16		1	*	
096-1	257262-3	RING 16	O	1		
097	251887-5	SCREW M6X10		1		
098	265708-5	THUMB SCREW M6X20		2	*	
098-1	911333-7	PAN HEAD SCREW M6X20	<	2		
100	631588-5	SOFT START CIRCUIT		1		
101	266300-0	TAPPING SCREW 4X18		1	*	
101-1	265678-8	TAPPING SCREW 4X18	O	1		
102	646073-5	CHOKE COIL		1		
103	645105-5	NOISE SUPPRESSOR		1	*	
103-1	645200-1	NOISE SUPPRESSOR	<	1		
104	654575-7	TERMINAL BLOCK		1		
105	651941-9	SWITCH V-15-2A5		1		
C10	654086-2	RECEPTACLE		2		
110	266091-3	TAPPING SCREW 4X50		2		
111	125180-2	LIGHT ASS'Y		1		
C10	152923-9	LAMP BOX COMPLETE G0121300 100		1		
C20	193730-1	FLUORESCENT LIGHT SET		1	*	
112	418072-5	SUPPORTER		1		
900	344572-8	LOCK PLATE		1		
901	323720-2	LOCK PIN 8		1	*	

901-1	326176-8	LOCK PIN 8	S	1		
902	231633-2	TORSION SPRING 8		1		
903	323721-0	ROD 8		1		
904	421589-9	CAP		1		
905	345302-0	LOCK LEVER		1	*	
905-1	345803-8	LOCK LEVER	S	1	*	
905-2	346619-4	LOCK LEVER	<	1		
906	911113-1	PAN HEAD SCREW M4X10 WITH WR		2		
907	911113-1	PAN HEAD SCREW M4X10 WITH WR		2		
908	424018-1	SUB LEVER		1		
A01	411478-6	SWITCH BUTTON		2	*	
A02	762001-3	TRIANGULAR RULE		1		
A03	782212-4	SOCKET WRENCH 13		1		
A04	122523-9	DUST BAG ASS'Y		1	*	
C10	410602-8	FASTENER		1	*	
A04-1	122852-0	DUST BAG ASS'Y	O	1		
C10	410602-8	FASTENER		1		
A05	193471-9	SUB PLATE ASS'Y		1	*	
C10	252148-6	SQUARE NUT M8		1	*	
C20	921431-9	HEX. BOLT M8X20		1	*	
A05-1	195934-1	SUB PLATE ASS'Y	<	1		
C10	252148-6	SQUARE NUT M8		1		
C20	921431-9	HEX. BOLT M8X20		1		
A06	122536-0	VICE ASS'Y		1		
C10	251370-2	+ PAN HEAD SCREW M5		1		
C20	251887-5	SCREW M6X10		1		
C30	253804-1	FLAT WASHER 6		1		
C40	271286-5	KNOB 40		1		
C50	316938-2	VICE ARM		1		
C60	322313-2	VICE ROD		1		
C70	343651-9	VICE PLATE		1		
A07	257022-3	RING 16		1		
A08	322312-4	HOLDER		2	*	
A08-1	123101-8	HOLDER ASSEMBLY	<	2		
C10	286212-1	CAP 20		4		
C20	326182-3	HOLDER		2		
C30	332036-4	ADJUSTER		4		
A09	A-80961	T.C.T.SAW BLADE 255X32X30		1		
F04	192622-1	CROWN MOLDING STOPPER SET		1		
015	855H23-9	LS1040F NAME PLATE		1		
018	417113-4	SWITCH BUTTON		1		
025	459017-4	SWITCH LEVER		1		
051-6	140E51-2	BLADE CASE COMPLETE		1		
086-2	140H28-5	BASE COMPLETE		1		
C30	813L22-1	CAUTION LABEL		2		
090	265455-8	HEX. BOLT M8X28		1		
095	265455-8	HEX. BOLT M8X28		1		
098-1	265708-5	THUMB SCREW M6X20		2		
101	265678-8	TAPPING SCREW 4X18		1		
103	645200-1	NOISE SUPPRESSOR		1		

A05-1	193471-9	SUB PLATE ASS'Y		1			
A08-1	322312-4	HOLDER		2			

Please state Parts No. when your order.

Print Date 10/23/2023