

### Model No.M8100 16MM HAMMER DRILL

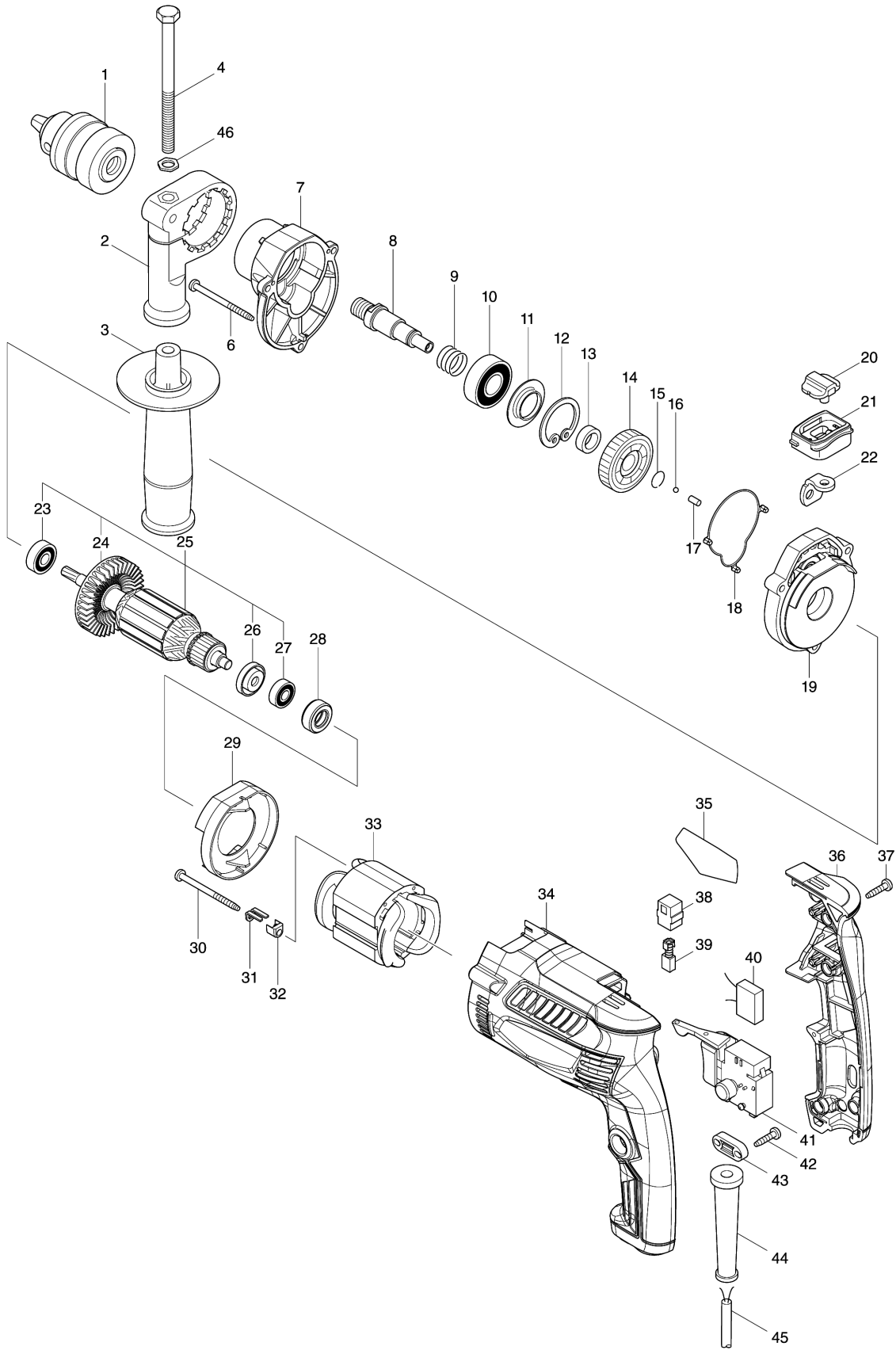

## Model No.M8100 16MM HAMMER DRILL

Item	Parts No.	Description	I/C	Qty	New/Old	Opt. 1	Opt. 2	Note
001	763161-4	DRILL CHUCK S13		1	*			
001-1	763232-7	DRILL CHUCK S13	O	1				
002	417822-5	GRIP BASE		1				
003	153503-4	GRIP 36 COMPLETE		1				
004	265495-6	HEX. BOLT M8X110		1				
006	266361-0	TAPPING SCREW 4X30		3				
007	451907-7	GEAR HOUSING		1				
008	324223-9	SPINDLE		1	*			
008-1	327220-4	SPINDLE	S	1	*			
008-2	327376-3	SPINDLE	S	1				
009	233330-6	COMPRESSION SPRING 16		1				
010	211241-5	BALL BEARING 6202DDW		1	*			
010-1	210241-2	BALL BEARING 6202DDW	O	1				
011	257246-1	RING 19		1				
012	962153-2	RETAINING RING R-35		1				
013	257173-2	RING 12		1				
014	226589-2	HELICAL GEAR 37		1				
015	233938-6	RING SPRING 12		1				
016	216001-0	STEEL BALL 3.5		1				
017	256251-5	PIN 4		1				
018	424112-9	SEAL RING		1				
019	140426-5	GEAR HOUSING COVER COMPLETE		1	*			
019-1	140G46-7	GEAR HOUSING COVER COMPLETE	S	1	*			
019-2	140M11-2	GEAR HOUSING COVER COMPLETE	S	1				
020	417819-4	CHANGE LEVER		1				
021	453921-9	LEVER CASE		1	*			
021-1	451908-5	LEVER CASE	<	1				
022	345944-0	CHANGE PLATE		1				
023	211031-6	BALL BEARING 608LLB		1				
024	241869-5	FAN 55		1				
025	510164-7	ARMATURE ASSEMBLY 240V		1				
D10		INC. 23,24,26,27						
026	681636-0	INSULATION WASHER		1				
027	210062-2	BALL BEARING 607ZZ		1				
028	421808-3	RUBBER RING 19		1				
029	450620-4	BAFFLE PLATE		1				
030	266415-3	TAPPING SCREW 4X55		2	*			
030-1	266467-4	TAPPING SCREW 4X50	S	2				
031	344871-8	RETAINER		2				
032	417237-6	INSULATION COVER		2	*			
033	626604-6	FIELD 240V		1	*			
033-1	621A39-2	FIELD	<	1				
034	455860-9	MOTOR HOUSING		1	*			
034-1	458780-6	MOTOR HOUSING	O	1				

Please order the parts with part number.

Print Date 27/10/2023

## Model No.M8100 16MM HAMMER DRILL

Item	Parts No.	Description	I/C	Qty	New/Old	Opt. 1	Opt. 2	Note
035	850X46-8	M8100 NAME PLATE		1				
036	141709-6	HANDLE COVER COMPLETE		1	*			
C10	263002-9	RUBBER PIN 4		2	*			
036-1	140427-3	HANDLE COVER COMPLETE	<	1				
C10	263002-9	RUBBER PIN 4		2				
037	266326-2	TAPPING SCREW 4X18		4				
038	643566-3	BRUSH HOLDER 5X8		2				
039	191998-3	CARBON BRUSH CB-85		1				
040	645200-1	NOISE SUPPRESSOR		1				
041	650586-0	SWITCH DGQ-1104H		1				
042	266326-2	TAPPING SCREW 4X18		2				
043	687124-5	STRAIN RELIEF		1				
044	682569-2	CORD GUARD 8-85		1	*			
044-1	682582-0	CORD GUARD	S	1				
045	665383-1	POWER SUPPLY CORD 1.0-2-2.0		1	*			
045-1	695556-2	POWER SUPPLY CORD 1.0-2-2.0	O	1	*			
045-2	665383-1	POWER SUPPLY CORD 1.0-2-2.0	O	1				
046	345280-4	HEX. WASHER		1				
A01	321144-6	DEPTH GAUGE		1				
A02	418163-2	KEY HOLDER 10		1	*			
A03	763441-8	CHUCK KEY S13		1	*			
A03-1	763235-1	CHUCK KEY S13	O	1				

Please order the parts with part number.

Print Date 27/10/2023