

Model No.MT081 CORDLESS HAMMER DRIVER DRILL

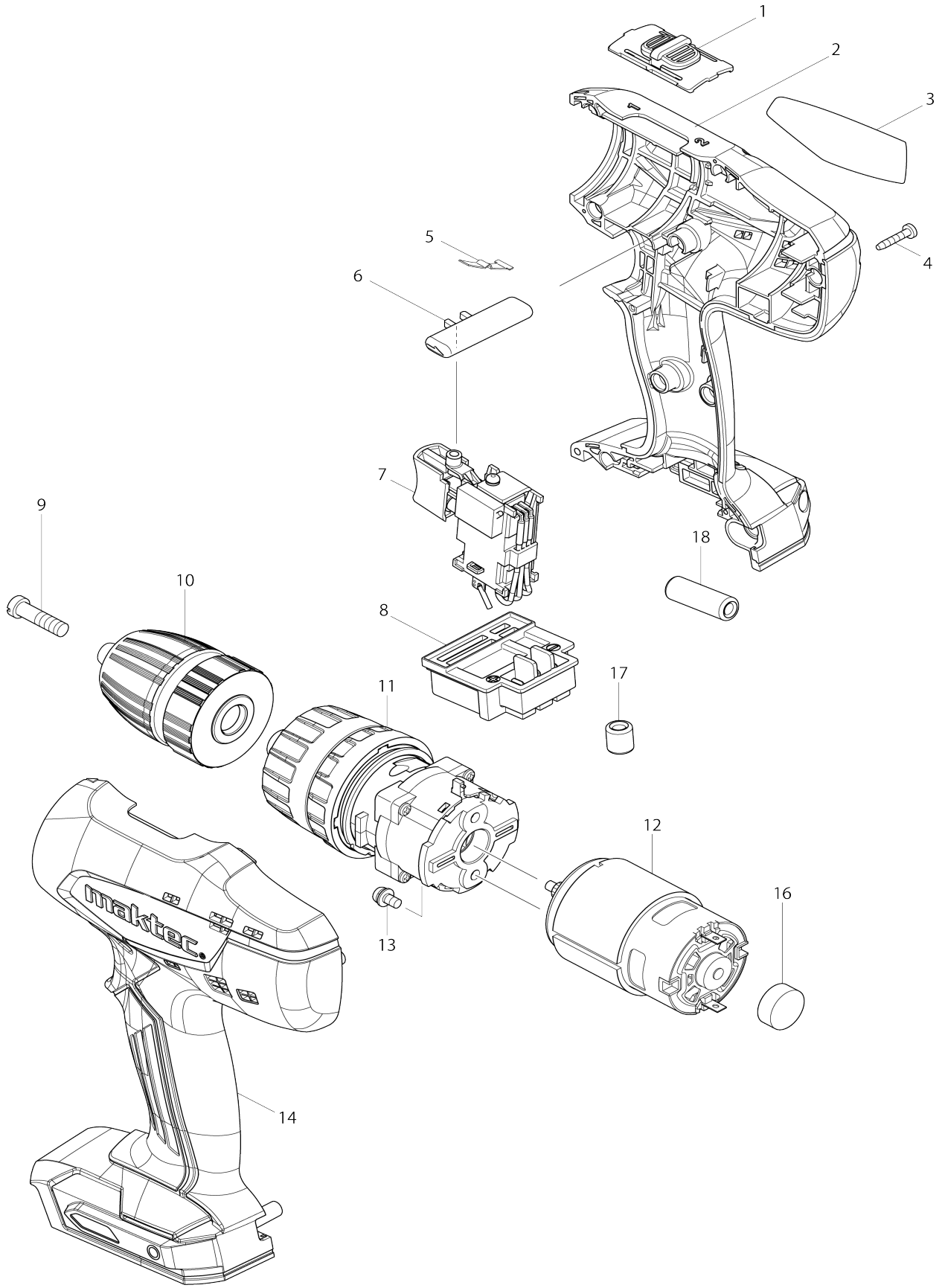

Model No.MT081 CORDLESS HAMMER DRIVER DRILL

Item No.	Parts No.	Description	Interchangeability	Q'ty	New/Old	Note1	Note2
001	125927-4	SPEED CHANGE LEVER ASS'Y		1			
C10	231433-0	COMPRESSION SPRING 4		2			
002	187032-5	HOUSING SET		1	*		
C10	252126-6	HEX. LOCK NUT M4-7		2	*		
D10		INC. 14					
002-1	187729-6	HOUSING SET	<	1			
C10	252126-6	HEX. LOCK NUT M4-7		2			
D10		INC. 14					
003	869132-0	MT081 NAME PLATE		1			
004	266429-2	TAPPING SCREW 3X16		9			
005	232182-2	LEAF SPRING		1			
006	452399-3	F/R CHANGE LEVER		1			
007	638861-4	SWITCH UNIT		1			
C10	654086-2	RECEPTACLE		2			
D10		INC. 17,18					
008	643869-5	TERMINAL		1			
009	251468-5	- FLAT HEAD SCREW M6X22		1			
010	766013-8	KEYLESS DRILL CHUCK 13		1			
011	140800-7	GEAR ASSEMBLY		1			
012	629834-8	DC MOTOR		1			
013	911108-4	PAN HEAD SCREW M4X8		2			
014	187032-5	HOUSING SET		1	*		
C10	252126-6	HEX. LOCK NUT M4-7		2	*		
D10		INC. 2					
014-1	187729-6	HOUSING SET	<	1			
C10	252126-6	HEX. LOCK NUT M4-7		2			
D10		INC. 2					
016	421940-3	CAP		1			
017	688164-6	LINE FILTER		1			
018	688165-4	LINE FILTER		1			
A01	824965-0	PLASTIC CASE		1			
C10	452143-8	SHAFT		2			
C20	452180-2	SLIDE LATCH		2			
C30	819906-9	MAKTEC LOGO LABEL		1			
A02	892095-5	MT081E PLASTIC CASE LABEL		2			
A04	***DC1851	DC1851 BATTERY CHARGER		1			
A05	452652-7	BATTERY COVER		1			
A06	195421-0	BATTERY L1851 SET		2	*		
A06-1	196369-9	BATTERY L1853 SET	O	2	*		
A06-2	198186-3	BATTERY BL1815G SET	O	2	*		
A06-3	198186-3	BATTERY BL1815G SET	<	2			
F02	198186-3	BATTERY BL1815G SET		1	*		
F02-1	198186-3	BATTERY BL1815G SET	<	1			

Please state Parts No. when your order.

Print Date 10/25/2023