

Seite / Page	Pos.	PLM5115	Teil-Nr. Part No. No. de pièce No. de pieza	Hinweise Notes Renseign. Nota	Bezeichnung	Spezifikation Specification	Description	Désignation	Denominación
3	A1	1	664 003 516		GEHÄUSE BLAU		DECK BLUE	CHÂSSIS BLEU	CAJA AZUL
3	A10	1	664 035 000		O-RING		O-RING	O-RING	JUNTA TÓRICA
3	A11	3	664 728 519		SCHRAUBE		SCREW	VIS	TORNILLO
3	A12	1	664 060 144		GEHÄUSE		DECK, ADJUSTMENT	CHÂSSIS REGLAGE	CARCASA, AJUSTE
3	A13	1	664 570 200		PLATTE, HÖHENVERSTELLUNG		PLATE, CUTTING POSITIONS	PLAQUETTE REGLAGE	PLANCHA, POSICIONES DE CORTE
3	A14	1	664 728 520		SCHRAUBE		SCREW	VIS	TORNILLO
3	A15	2	664 521 350		SCHEIBE		WASHER	RONDELLE	ARANDELA
3	A17	1	664 778 397		HALTER, LINKS		BRACKET, LEFT	BRIDE GAUCHE	SOPORTE, IZQ.
3	A17 1	1	664 140 224		MULCHEINSATZ		MULCH PLUG	INSERT MULCH	TAPA
3	A18	2	664 203 854		ABDECKKAPPE		PROTECTION	CAPUCHON	CAPERUZA
3	A2	4	664 735 420		SCHRAUBE		SCREW	VIS	TORNILLO
3	A20	1	664 778 396		HALTER, RECHTS		BRACKET, RIGHT	BRIDE DROITE	SOPORTE, DER.
3	A22	2	664 155 000		MUTTER		NUT	ECROU	TUERCA
3	A23	2	664 793 102		SCHRAUBE		SCREW	VIS	TORNILLO
3	A24	1	664 595 352		ABDECKPLATTE		INSPECTION DOOR	VOYANT DE VISITE	PUERTA DE INSPECCIÓN
3	A25	1	664 729 600		SCHRAUBE		SCREW	VIS	TORNILLO
3	A26	1	664 108 205		ABDECKBLECH		PLATE	CONVOYEUR	PLANCHA PROTECTORA
3	A27	1	664 789 000		SCHRAUBE		SCREW	VIS	TORNILLO
3	A28	1	664 523 020		SCHEIBE		WASHER	RONDELLE	ARANDELA
3	A29	1	664 154 330		MUTTER		NUT	ECROU	TUERCA
3	A3	1	664 226 109		MASKE		MASK	MESQUE	CARETA
3	A30	4	664 731 350		SCHRAUBE		SCREW	VIS	TORNILLO
3	A31	2	664 545 147		PLATTE		PLATE	PLAQUETTE	PLANCHA
3	A33	2	664 038 407		BUCHSE		BUSH	DOUILLE	CASQUILLO
3	A34	4	664 731 350		SCHRAUBE		SCREW	VIS	TORNILLO
3	A35	2	664 545 156		PLATTE		PLATE	PLAQUETTE	PLANCHA
3	A36	2	664 038 400		BUCHSE		BUSH	DOUILLE	CASQUILLO
3	A5	2	664 728 522		SCHRAUBE		SCREW	VIS	TORNILLO
3	A51	1	664 302 847		ACHSE, VORDERRAD		AXLE, FRONT WHEELS	AXE ROUES AVANT	EJE, RUEDAS DELANTERAS
3	A58	1	664 002 040		STANGE, HÖHENVERSTELLUNG		ROD, HEIGHT ADJUSTMENT CONTROL	TIGE COMMANDE REGLAGE HAUTEUR	VÁSTAGO, AJUSTE ALTURA
3	A59	2	664 000 930		SPRENGRING		SAFETY WASHER	RONDELLE DE SÉCURITÉ	ANILLO DE SEGURIDAD
3	A6	1	664 060 200		SCHUTZ		PROTECTION	PROTECTION	PROTECCIÓN
3	A61	1	664 446 187		FEDER		SPRING	RESSORT	MUELLE
3	A62	2	664 604 899		SICHERUNGSSCHEIB E		SAFETY WASHER	RONDELLE DE SÉCURITÉ	ARANDELA SEGURIDAD
3	A63	1	664 529 662		BOLZEN		PIN	PIVOT	PIVOTE
3	A64	1	664 672 151		SCHEIBE		WASHER	RONDELLE	ARANDELA
3	A65	1	664 001 269		STANGE, HINTERRADACHSE		ROD, REAR WHEELS AXLE	TIGE, AXE ROUE ARRIERES	VÁSTAGO, EJE RUEDAS TRASERAS
3	A66	1	664 000 479		SEKTOR, HÖHENVERSTELLUNG		SECTOR, HEIGHT ADJUSTMENT	SECTEUR REGLAGE HAUTEUR	SECTOR, AJUSTE ALTURA
3	A67	1	664 672 152		SCHEIBE		WASHER	RONDELLE	ARANDELA
3	A68	1	664 785 109		HALTER		SUPPORT, HEIGHT	SUPPORT REGLAGE	SOPORTE, ALTURA
3	A69	1	664 293 201		MUTTER		NUT	ECROU	TUERCA
3	A7	1	664 729 600		SCHRAUBE		SCREW	VIS	TORNILLO
3	A70	2	664 793 301		SCHRAUBE		SCREW	VIS	TORNILLO
3	A71	1	664 785 113		HALTER, GRIFF		SUPPORT, HANDLE	SUPPORT POIGNÉE	SOPORTE, MANILLAR
3	A72	2	664 293 201		MUTTER		NUT	ECROU	TUERCA
3	A73	1	664 729 600		SCHRAUBE		SCREW	VIS	TORNILLO
3	A74	1	664 793 301		SCHRAUBE		SCREW	VIS	TORNILLO
3	A75	2	664 038 002		BUCHSE		BUSH	DOUILLE	CASQUILLO
3	A76	1	664 393 611		GRIFF		KNOB	POIGNÉE	MANETA
3	A78	1	664 293 201		MUTTER		NUT	ECROU	TUERCA
3	A79	1	664 622 640		STIFT		PIN	GOUPILLE	PASADOR
3	A8	2	664 523 040		SCHEIBE		WASHER	RONDELLE	ARANDELA

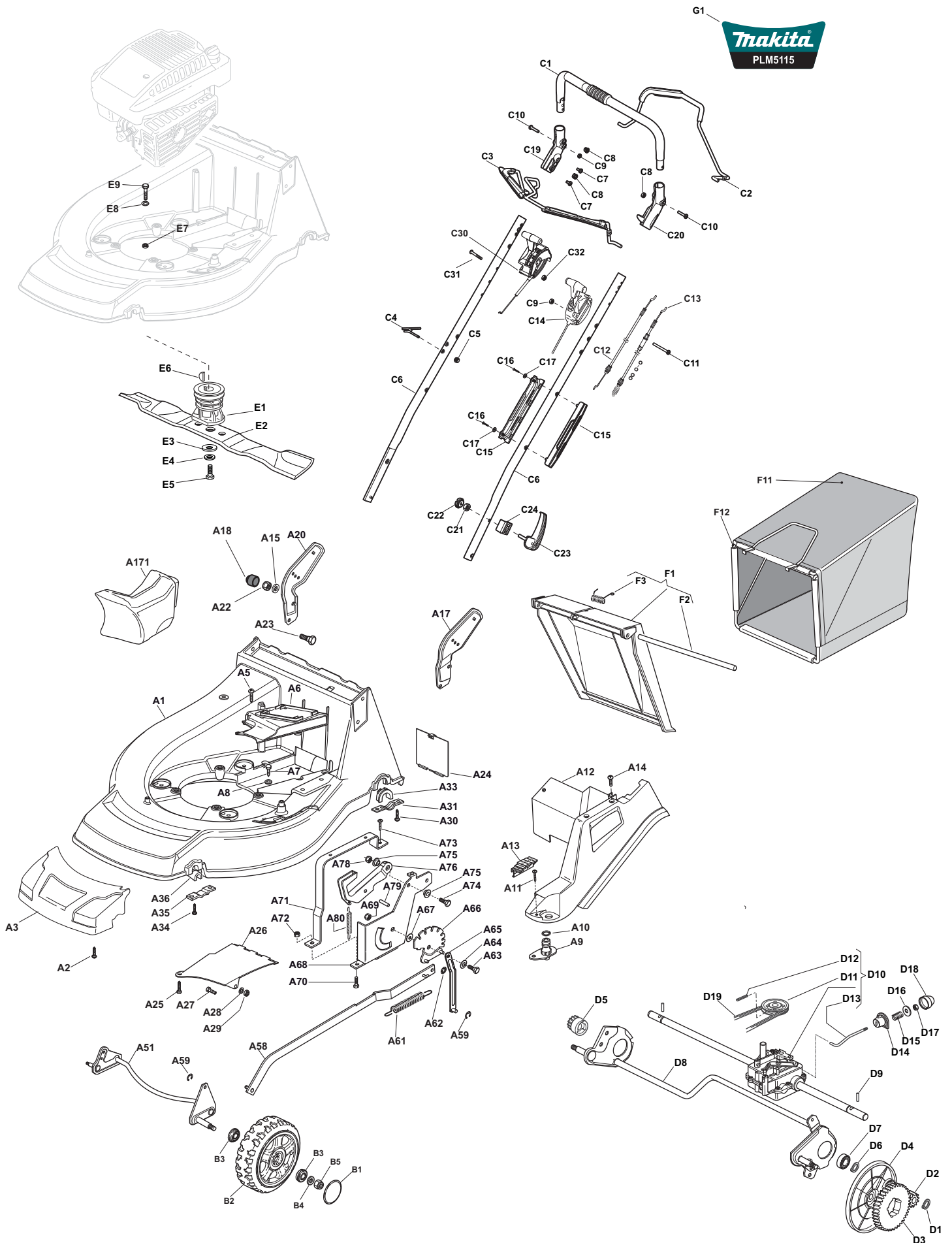

Seite / Page	Pos.	PLM5115	Teil-Nr. Part No. No. de pièce No. de pieza	Hinweise Notes Renseign. Nota	Bezeichnung	Spezifikation Specification	Description	Désignation	Denominación
3	A80	1	664 446 175		FEDER		SPRING	RESSORT	RESORTE
3	A9	1	664 034 000		SCHLAUCHANSCHLUSS		WASHING CONNECTION	ATTAQUE LAVAGE	RACOR DE EMPALME
3	B1	4	664 110 653		RADKAPPE		WHEEL COVER	CHAPEAU DE MOYEU	CAPERUZA DE RUEDA
3	B2	4	664 007 409		RAD	Ø 210	WHEEL	ROUE	RUEDA
3	B3	8	664 216 035		LAGER		BEARING	COUSSINET	RODAMIENTO
3	B4	4	664 521 350		SCHEIBE		WASHER	RONDELLE	ARANDELA
3	B5	4	664 155 000		MUTTER		NUT	ECROU	TUERCA
3	C1	1	664 006 670		HANDGRIFF		HANDGRIP	POIGNÉE	MANGO
3	C10	2	664 728 721		SCHRAUBE		SCREW	VIS	TORNILLO
3	C11	1	664 727 786		SCHRAUBE		SCREW	VIS	TORNILLO
3	C12	1	664 030 077		BOWDENZUG (MOTORBREMSE)		CONTROL CABLE (MOTOR BRAKE)	CÂBLE BOWDEN (FREIN MOTEUR)	TRACCIÓN BOWDEN (FRENO MOTOR)
3	C13	1	664 030 078		BOWDENZUG (RADANTRIEB)		CONTROL CABLE (WHEEL DRIVE)	CÂBLE BOWDEN (ENTRAÎNEMENT DE ROUE)	TRACCIÓN BOWDEN (TRACCIÓN DE RUEDA)
3	C14	1	664 007 199		GASHEBEL MIT BOWDENZUG		THROTTLE LEVER WITH CONTROL CABLE	ACCÉLÉRATEUR AVEC CÂBLE BOWDEN	PALANCA DEL ACELERADOR CON TRACCIÓN BOWDEN
3	C15	2	664 806 644		SCHUTZ		PROTECTION	PROTECTION	PROTECTOR
3	C16	2	664 727 812		SCHRAUBE		SCREW	VIS	TORNILLO
3	C17	2	664 523 000		SCHEIBE		WASHER	RONDELLE	ARANDELA
3	C19	1	664 488 301		HALTER, RECHTS		SUPPORT, R	SUPPORT D	SOPORTE DER.
3	C2	1	664 003 349		HEBEL, ANTRIEB		LEVER, DRIVING	LEVIER TRACTION	PALANCA, CONDUCCIÓN
3	C20	1	664 488 303		HALTER, LINKS		SUPPORT, L	SUPPORT G	SOPORTE, IZQ.
3	C21	2	664 131 750		MUTTER		NUT	ECROU	TUERCA
3	C22	2	664 399 835		GRIFF		GRIP	POIGNÉE	MANGO
3	C23	2	664 003 253		GRIFF		HANDLE	POIGNÉE	MANGO
3	C24	2	664 680 017		HALTER		SUPPORT	SUPPORT	SOPORTE
3	C3	1	664 003 344		HEBEL, MOTORBREMSE		LEVER, MOTOR BRAKE	LEVIER FREIN MOTEUR	PALANCA, FRENO MOTOR
3	C30	1	664 007 195		BOWDENZUG, GANGSCHALTUNG		BOWDEN CABLE, SPEED DRIVE CONTROL	CÂBLE BOWDEN, COMM. CHANGEMENT VITESSE	CABLE BOWDEN, CAJA DE CAMBIOS
3	C31	1	664 727 786		SCHRAUBE		SCREW	VIS	TORNILLO
3	C32	1	664 154 510		MUTTER		NUT	ECROU	TUERCA
3	C4	1	664 430 309		FEDERFÜHRUNG		GUIDE SPRING	RESSORT DE GUIDE	RESORTE DE GUÍA
3	C5	1	664 154 330		MUTTER		NUT	ECROU	TUERCA
3	C6	2	664 007 046		HOLM	BLACK	HANDLE	MANCHERON	MANILLAR
3	C7	4	664 735 662		SCHRAUBE		SCREW	VIS	TORNILLO
3	C8	4	664 041 967		BUCHSE		BUSH	DOUILLE	CASQUILLO
3	C9	3	664 154 510		MUTTER		NUT	ECROU	TUERCA
3	D1	2	664 608 600		SICHERUNGSRING		SEEGER	SEEGER	ANILLO DE SEGURIDAD
3	D10	1	664 003 080		ANTRIEB		GEAR BOX	GROUPE TRACTION	UNIDAD DE TRACCIÓN
3	D11	1	664 601 908		RIEMENSCHLEIBE		PULLEY	POULIE	POLEA
3	D12	1	664 645 705		STIFT		PIN	GOUPILLE	PASADOR
3	D13	1	664 033 282		VERSTELLHEBEL		ADJUSTMENT ROD	TIGE REGLAGE	VÁSTAGO DE AJUSTE
3	D14	1	664 041 957		BUCHSE		BUSH	DOUILLE	CASQUILLO
3	D15	1	664 450 063		FEDER		SPRING	RESSORT	RESORTE
3	D16	1	664 680 009		SCHEIBE		WASHER	RONDELLE	ARANDELA
3	D17	1	664 154 510		MUTTER		NUT	ECROU	TUERCA
3	D18	1	664 110 230		NABENDECKEL		HUB COVER	COUVRE MOYEU	TAPACUBOS
3	D19	1	664 064 197		RIEMEN	(Z LP 885)	BELT	COURROIRE	CORREA
3	D2	1	664 570 120		RITZEL LINKS		PINION L	PIGNON G	PIÑÓN, IZQ.
3	D3	2	664 120 105		ZAHNRAD		RING GEAR	COURONNE	CORONA DENTADA
3	D4	2	664 600 218		SCHUTZABDECKUNG		PROTECTION	PROTECTION	PROTECTOR
3	D5	1	664 570 110		RITZEL RECHTS		PINION RIGHT	PIGNON D	PIÑÓN, DER.
3	D6	2	664 608 600		SICHERUNGSRING		SEEGER	SEEGER	ANILLO DE SEGURIDAD
3	D7	2	664 216 035		LAGER		BEARING	COUSSINET	RODAMIENTO
3	D8	1	664 302 845		ACHSE, HINTERRAD		AXLE, REAR WHEELS	AXE ROUES ARRIERE	EJE, RUEDAS TRASERAS

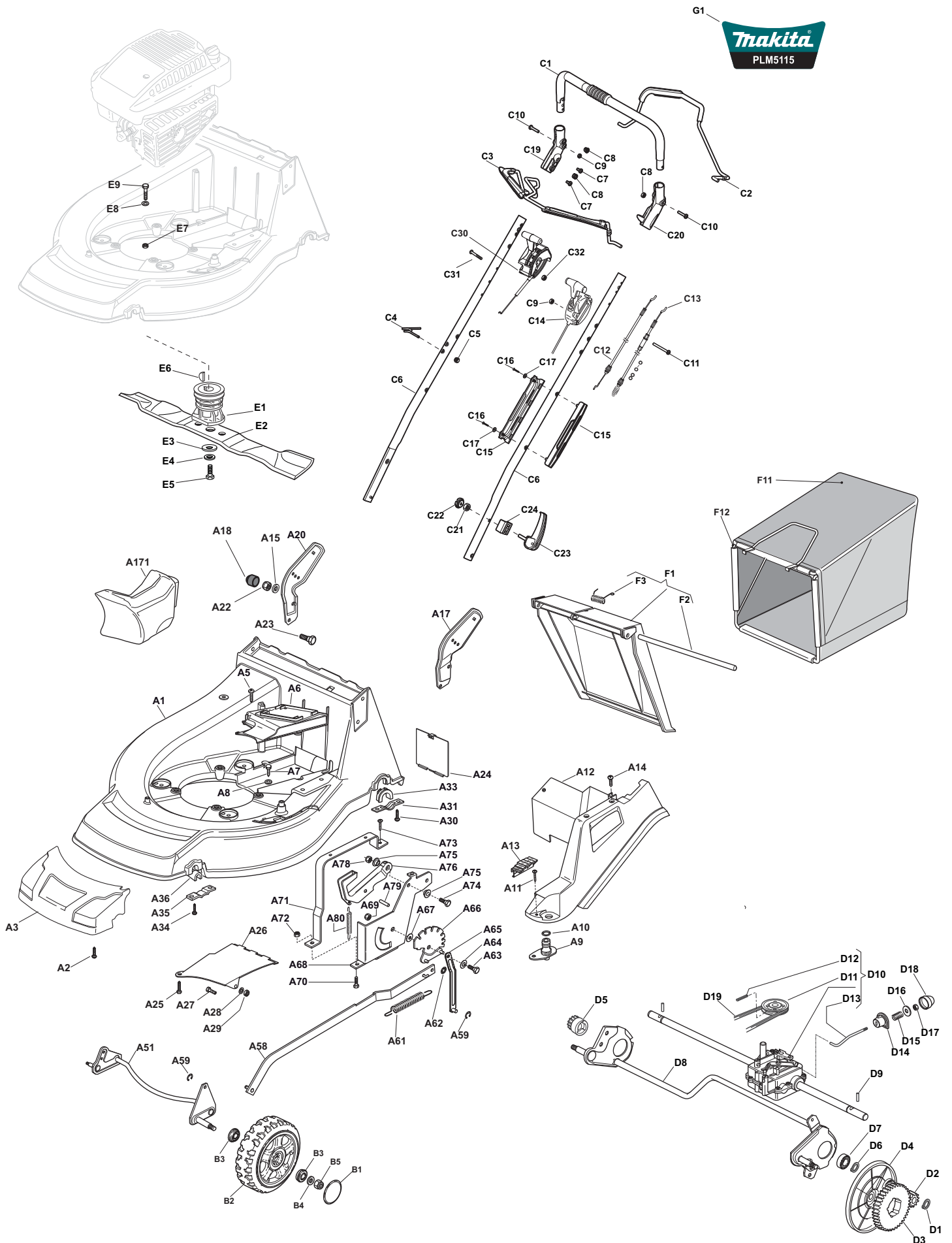

(2011) PLM4815, PLM4816,
PLM5114, PLM5115

3

PLM5115
PLM5115
PLM5115
PLM5115



Seite / Page	Pos.	PLM5115	Teil-Nr. Part No. No. de pièce No. de pieza	Hinweise Notes Renseign. Nota	Bezeichnung	Spezifikation Specification	Description	Désignation	Denominación
3	D9	2	664 753 000		STIFT		PIN	GOUPILLE	PASADOR
3	E1	1	664 465 608		MESSERHALTER		HUB WITH PULLEY	MOYEU AVEC POULIE	SOPORTE DE LA CUCHILLA
3	E2	1	664 004 381		MULCHMESSER		BLADE (COLLECT AND MULCH)	LAME	CUCHILLA ESTÁNDAR
3	E3	1	664 160 400		FEDERSCHEIBE		ELASTIC WASHER	RONDELLE ELASTIQUE	ARANDELA ELÁSTICA
3	E4	1	664 523 080		SCHEIBE		WASHER	RONDELLE	ARANDELA
3	E5	1	664 735 698		SCHRAUBE		SCREW	VIS	TORNILLO
3	E6	1	664 139 150		KEIL		FEATHER	CLAVETTE	CHAVETA
3	E7	3	664 155 000		MUTTER		NUT	ECROU	TUERCA
3	E8	3	664 521 350		SCHEIBE		WASHER	RONDELLE	ARANDELA
3	E9	1	664 735 108		SCHRAUBE		SCREW	VIS	TORNILLO
3	F1	1	664 008 114		PRALLBLECH		STONE-GUARD	PARE-PIERRES	CUBIERTA PROTECTORA
3	F11	1	664 002 124		SACK, TUCH		BOX, FABRIC	SAC, TOILE	CESTO, TELA
3	F12	1	664 006 430		RAHMEN		FRAME	CADRE	MARCO
3	F2	1	664 450 270		FEDER		SPRING	RESSORT	MUELLE
3	F3	1	664 517 907		BOLZEN		PIN	PIVOT	PIVOTE
3	G1	1	664 365 738		SCHILD	PLM5115	LABEL	PLAQUE	CALCOMANIA