



Ersatzteilliste
Spare Parts List

2015-09

TM-92.14 (2015)

TM-92.14 H (2015)

(D, GB)

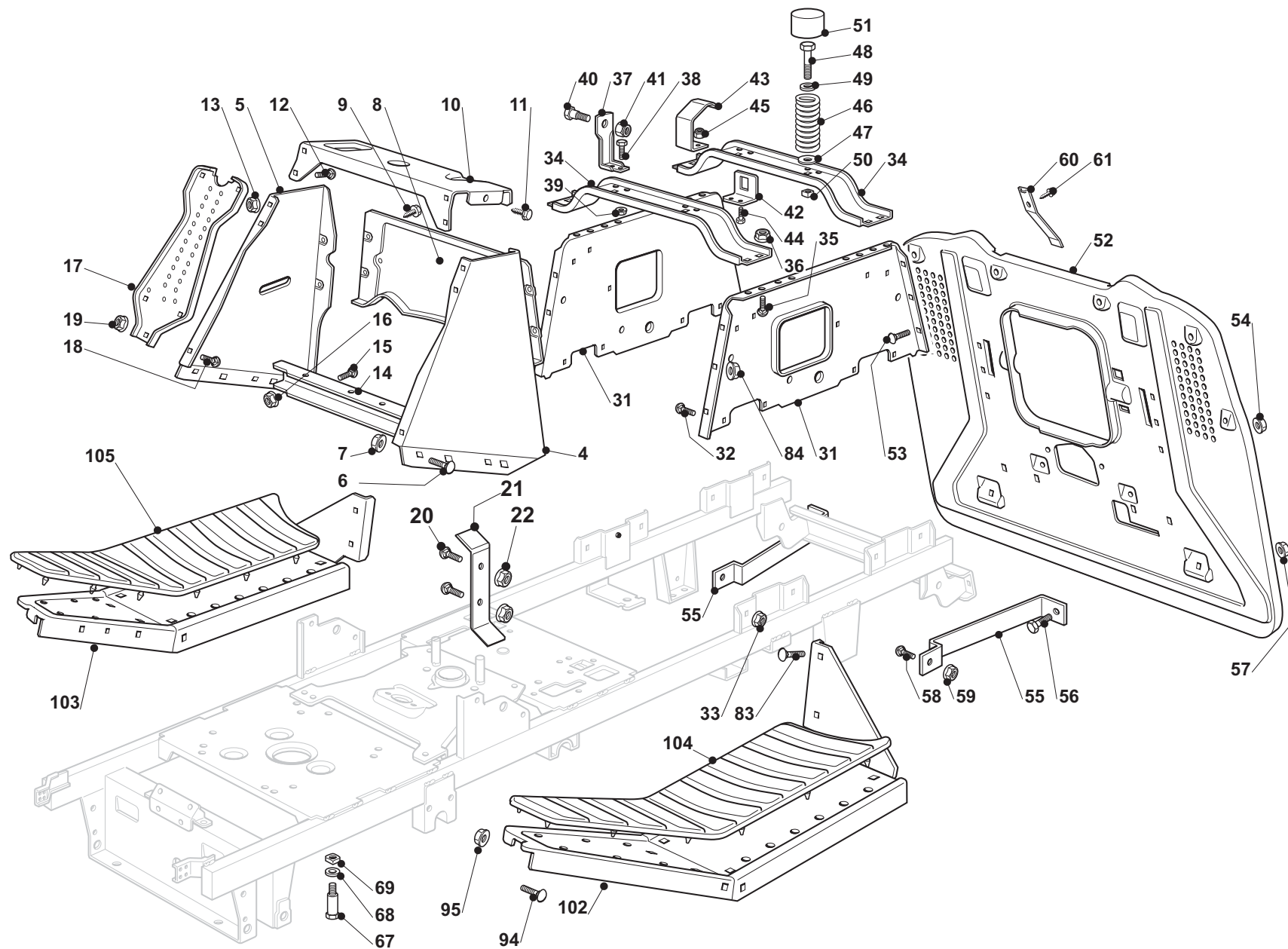



Seite / Page	Pos.	TM-92.14 (2015)	TM-92.14 H (2015)	Teil-Nr. Part No.	Hinweise Notes	Bezeichnung	Spezifikation Specification	Description
1	4	1	1	664999243		KONSOLENHALTER LINKS		SUPPORT
1	5	1	1	664785245		KONSOLENHALTER RECHTS		SUPPORT
1	6	4	4	664818690		SCHRAUBE		SCREW
1	7	4	4	664293201		MUTTER		NUT
1	8	1	1	664028497		KONSOLE HINTERRAD		REAR DASHBOARD SUPP
1	9	4	4	664735110		SCHRAUBE		SCREW
1	10	1	1	664785255		HALTER		SUPPORT
1	11	2	2	664735110		SCHRAUBE		SCREW
1	12	4	4	664815200		SCHRAUBE		SCREW
1	13	4	4	664292102		MUTTER		NUT
1	14	1	1	664785241		HALTER		SUPPORT
1	15	2	2	664815200		SCHRAUBE		SCREW
1	16	2	2	664292102		MUTTER		NUT
1	17	2	2	664785153		KONSOLE VORDERRAD		FRONT DASHBOARD SUPP
1	18	2	2	664815200		SCHRAUBE		SCREW
1	19	2	2	664292102		MUTTER		NUT
1	20	2	2	664793102		SCHRAUBE		SCREW
1	21	1	1	664028498		HALTER		SUPPORT
1	22	2	2	664293201		MUTTER		NUT
1	31	2	2	664028499		SITZHALTER		SUPPORT
1	32	8	8	664815200		SCHRAUBE		SCREW
1	33	8	8	664292102		MUTTER		NUT
1	34	2	2	664785257		SITZHALTER		SUPPORT
1	35	8	8	664818690		SCHRAUBE		SCREW
1	36	8	8	664293201		MUTTER		NUT
1	37	2	2	664755039		WINKEL		BRACKET
1	38	4	4	664792611		SCHRAUBE		SCREW
1	39	4	4	664293201		MUTTER		NUT
1	40	2	2	664524970		BOLZEN		PIN
1	41	2	2	664155010		MUTTER		NUT
1	42	1	1	664755043		WINKEL		BRACKET
1	43	1	1	664430253		FEDER		SPRING
1	44	2	2	664789000		SCHRAUBE		SCREW
1	45	2	2	664154330		MUTTER		NUT
1	46	2	2	664430257		FEDER		SPRING
1	47	2	2	664523070		SCHEIBE		WASHER
1	48	2	2	664760515		SCHRAUBE		SCREW
1	49	2	2	664671653		SCHEIBE		WASHER
1	50	2	2	664360425		MUTTER		NUT
1	51	2	2	664122000		SCHUTZKAPPE		HOOD
1	52	1	1	664947041		PLATTE		PLATE
1	53	6	6	664792611		SCHRAUBE		SCREW

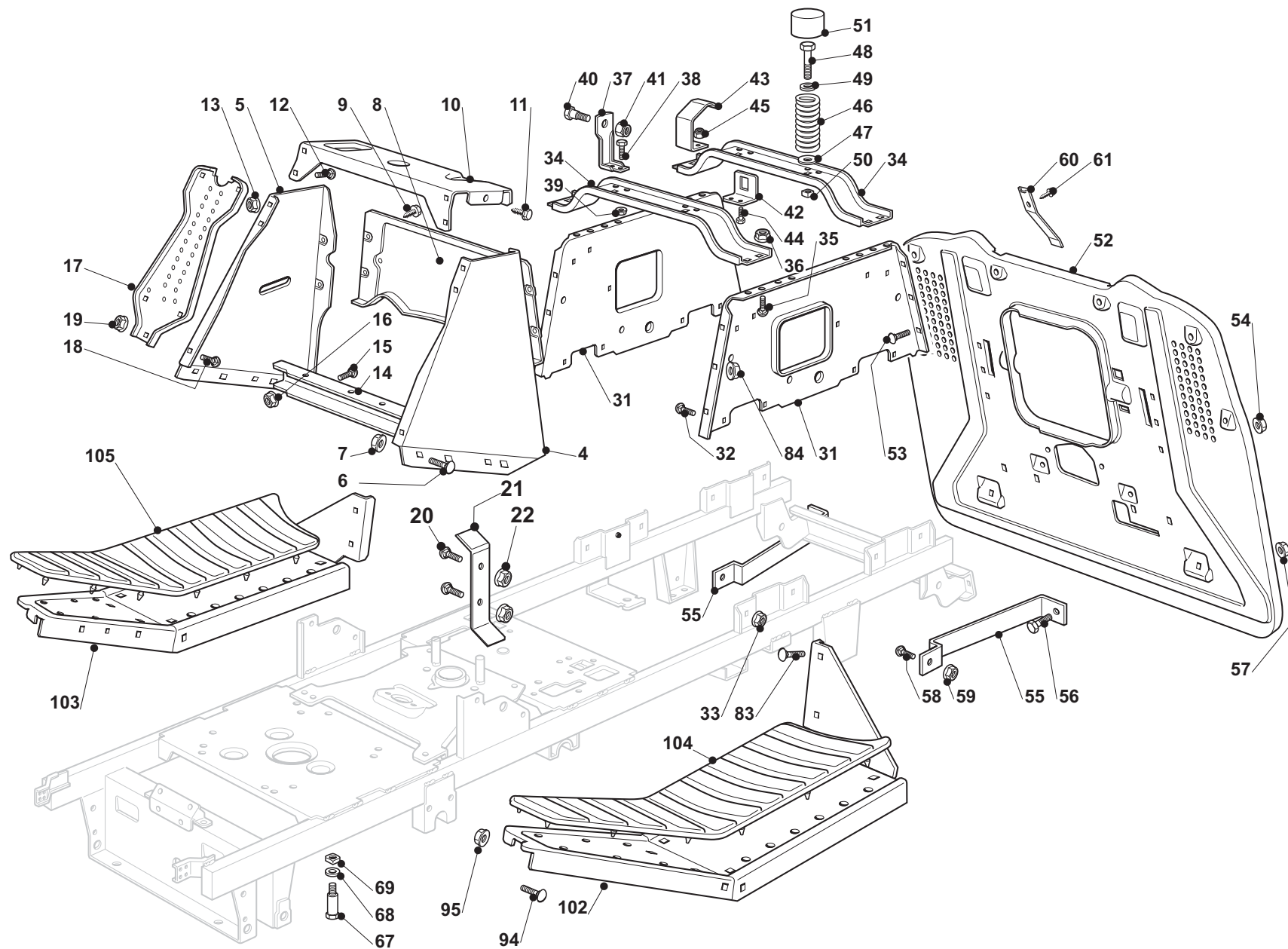



Seite / Page	Pos.	TM-92.14 (2015)	TM-92.14 H (2015)	Teil-Nr. Part No.	Hinweise Notes	Bezeichnung	Spezifikation Specification	Description
1	54	6	6	664293201		MUTTER		NUT
1	55	2	2	664650119		PLATTE		PLATE
1	56	2	2	664792611		SCHRAUBE		SCREW
1	57	2	2	664293201		MUTTER		NUT
1	58	2	2	664792611		SCHRAUBE		SCREW
1	59	2	2	664293201		MUTTER		NUT
1	60	1	1	664028500		FEDER		SPRING
1	61	1	1	664735110		SCHRAUBE		SCREW
1	67	2		664580030		RIEMENFÜHRUNG		BELT GUIDE
1	68	2	2	664523060		SCHEIBE		WASHER
1	69	2	2	664360425		MUTTER		NUT
1	83	4	4	664792611		SCHRAUBE		SCREW
1	84	4	4	664293201		MUTTER		NUT
1	94	4	4	664815200		SCHRAUBE		SCREW
1	95	4	4	664292102		MUTTER		NUT
1	102	1	1	664251008		FUSSBRETTALTER LINKS		FOOTBOARD SUPPORT
1	103	1	1	664510081		FUSSBRETTALTER RECHTS		FOOTBOARD SUPPORT
1	104	1	1	664110327		FUSSBRETTDECKEL RECHTS		RIGHT FOOTBOARD COVER
1	105	1	1	664110326		FUSSBRETTDECKEL LINKS		LEFT FOOTBOARD COVER

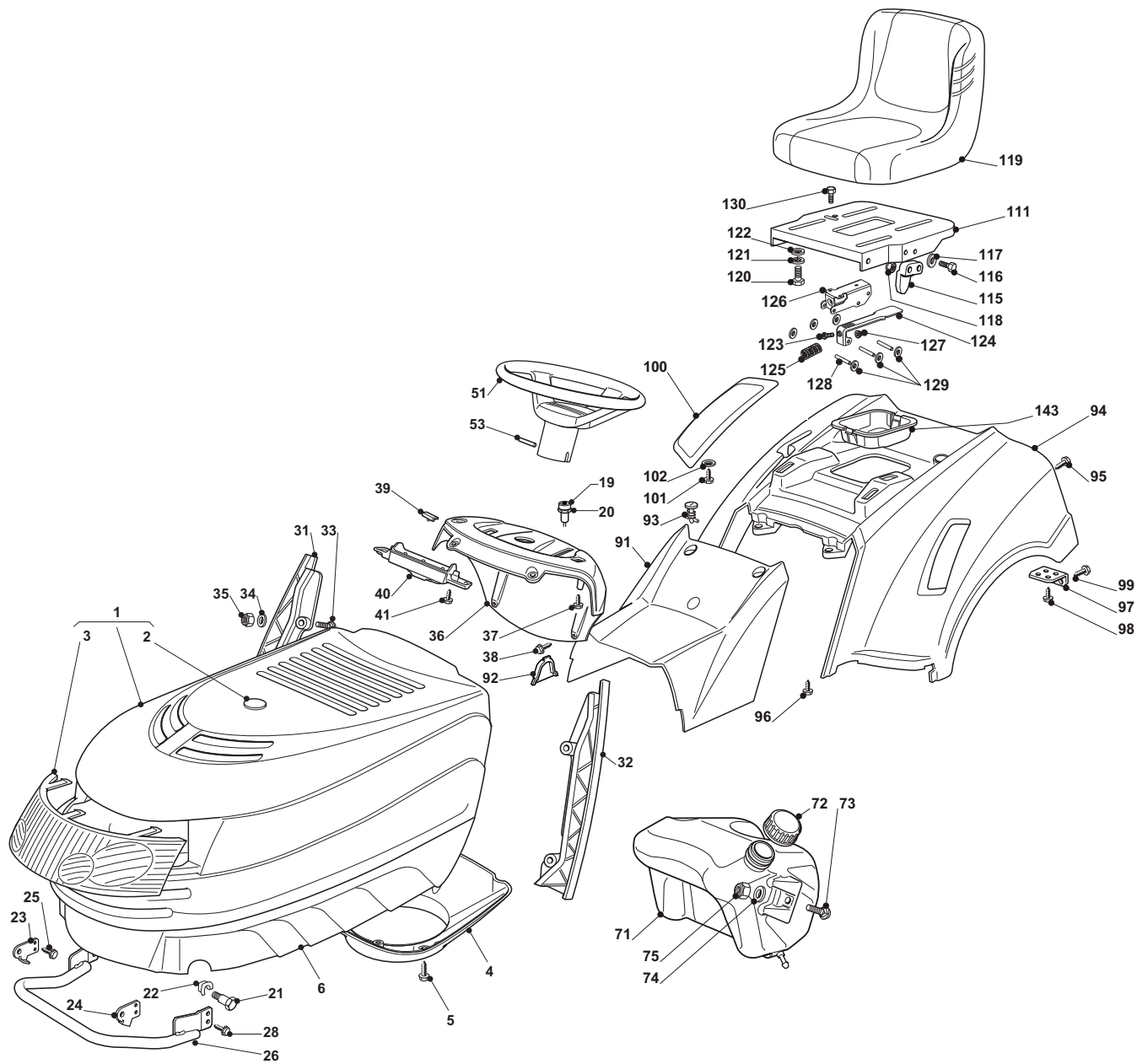



Seite / Page	Pos.	TM-92.14 (2015)	TM-92.14 H (2015)	Teil-Nr. Part No.	Hinweise Notes	Bezeichnung	Spezifikation Specification	Description
2	1	1	1	664076938		OBERHAUBE	INC. 2,3	HOOD
2	2	1	1	664547103		PLATTE		PLATE
2	3	1	1	664410859		FRONTTEIL		GRILL
2	4	1	1	664108028		ABDECKUNG		COVER
2	5	3	3	664728686		SCHRAUBE		SCREW
2	6	1	1	664076808		UNTERHAUBE		HOOD
2	19	1	1	664028501		KNOPF		BUTTON
2	20	1	1	664028502		NUTMUTTER		RING NUT
2	21	2	2	664510023		BOLZEN		PIN
2	22	2	2	664436050		PLATTE		PLATE
2	23	1	1	664547089		PLATTE RECHTS		PLATE
2	24	1	1	664547091		PLATTE LINKS		PLATE
2	25	4	4	664731580		SCHRAUBE		SCREW
2	26	1	1	664028503		AUSPUFFSCHUTZ		MUFFLER PROTECTION
2	28	4	4	664734995		SCHRAUBE		SCREW
2	31	1	1	664028504		RECHTER KONSOLENHALTER		RIGHT DASHBOARD SUPP.
2	32	1	1	664028505		LINKER KONSOLENHALTER		LEFT DASHBOARD SUPP.
2	33	4	4	664815221		SCHRAUBE		SCREW
2	34	4	4	664521330		SCHEIBE		WASHER
2	35	4	4	664154510		MUTTER		NUT
2	36	1	1	664028506		KONSOLE		DASHBOARD
2	37	2	2	664728440		SCHRAUBE		SCREW
2	38	2	2	664735402		SCHRAUBE		SCREW
2	39	2	2	664260000		GUMMISTOPFEN		GROMMET
2	40	1	1	664600074		SCHUTZ		PROTECTION
2	41	2	2	664735402		SCHRAUBE		SCREW
2	51	1	1	664961216		LENKRAD		STEERING WHEEL
2	53	1	1	664620300		STIFT		PIN
2	71	1	1	664735128		TANK		TANK
2	72	1	1	664795000		TANKVERSCHLUSS		CAP
2	73	2	2	664815210		SCHRAUBE		SCREW
2	74	2	2	664160039		DISTANZSTÜCK		SPACER
2	75	2	2	664154510		MUTTER		NUT
2	91	1	1	664110378		ABDECKUNG, ROT		COVER, RED
2	92	1		664207172		PLATTE		PLATE
2	93	2	2	664558002		STIFT		PIN
2	94	1	1	664110329		RADABDECKUNG, ROT		COVER, RED
2	95	4	4	664735402		SCHRAUBE		SCREW
2	96	2	2	664735402		SCHRAUBE		SCREW
2	97	2	2	664755041		WINKEL		BRACKET
2	98	4	4	664728686		SCHRAUBE		SCREW
2	99	2	2	664735110		SCHRAUBE		SCREW

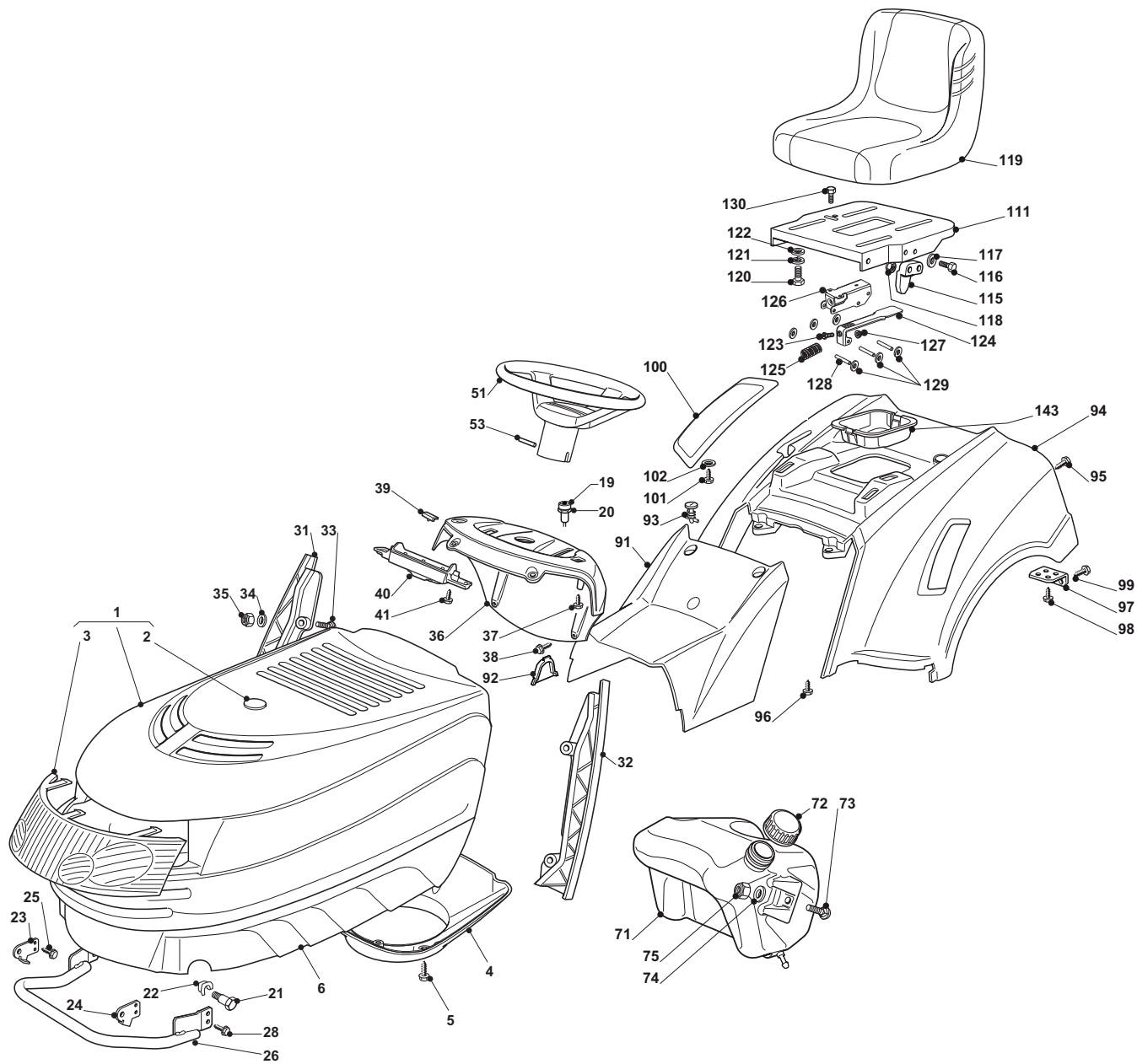



Seite / Page	Pos.	TM-92.14 (2015)	TM-92.14 H (2015)	Teil-Nr. Part No.	Hinweise Notes	Bezeichnung	Spezifikation Specification	Description
2	100		1	664207171		KAPPE		CAP
2	101		2	664735402		SCHRAUBE		SCREW
2	102		4	664523050		SCHEIBE		WASHER
2	111	1	1	664028507		PLATTE		PLATE
2	115	1	1	664063021		NOCKEN		CAM
2	116	2	2	664789100		SCHRAUBE		SCREW
2	117	2	2	664523020		SCHEIBE		WASHER
2	118	2	2	664154330		MUTTER		NUT
2	119	1	1	664722463		SITZ		SEAT
2	120	4	4	664793101		SCHRAUBE	M8x16	SCREW
2	121	4	4	664583500		FEDERRING		GROWER
2	122	4	4	664523060		SCHEIBE		WASHER
2	123	1	1	664028508		SCHRAUBE		SCREW
2	124	1	1	664028509		HEBEL		LEVER
2	125	1	1	664028510		FEDER		SPRING
2	126	1	1	664028511		BÜGEL		FULCRUM CLAMP
2	127	1	1	664154510		MUTTER		NUT
2	128	3	3	664028479		BOLZEN		PIN
2	129	6	6	664604896		SICHERUNGSSCHEIBE		SAFETY WASHER
2	130	2	2	664789000		SCHRAUBE		SCREW
2	143	1	1	664207176		BECKEN		BASIN

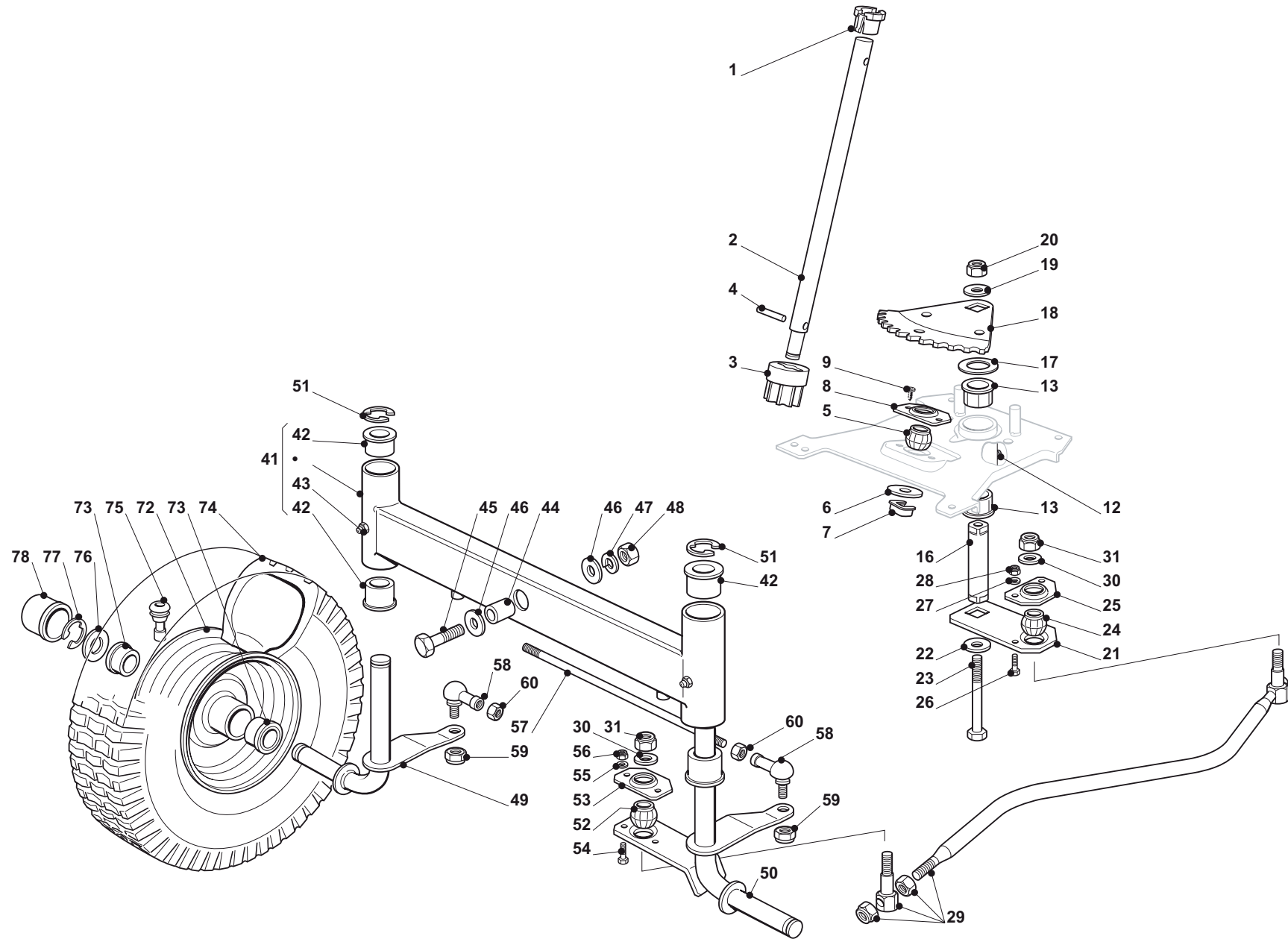



Seite / Page	Pos.	TM-92.14 (2015)	TM-92.14 H (2015)	Teil-Nr. Part No.	Hinweise Notes	Bezeichnung	Spezifikation Specification	Description
3a	1	1	1	664038004		BUCHSE		BUSH
3a	2	1	1	664520006		LENKSÄULE		STEERING COLUMN
3a	3	1	1	664570050		RITZEL		PINION
3a	4	1	1	664622650		STIFT		PIN
3a	5	1	1	664743000		GELENK		JOINT
3a	6	1	1	664521370		SCHEIBE		WASHER
3a	7	1	1	664436030		PLÄTTCHEN		PLATE
3a	8	1	1	664785213		HALTER		SUPPORT
3a	9	2	2	664729601		SCHRAUBE		SCREW
3a	12	1	1	664379511		FETTBUCHSE		GREASE DISPENSER
3a	13	2	2	664040624		BUCHSE		BUSH
3a	16	1	1	664510092		BOLZEN		PIN
3a	17	1	1	664670019		SCHEIBE		WASHER
3a	18	1	1	664735513		LENKWELLE		STEERING SHAFT
3a	19	1	1	664523080		SCHEIBE		WASHER
3a	20	1	1	664155020		MUTTER		NUT
3a	21	1	1	664318205		HEBEL		LEVER
3a	22	1	1	664523080		SCHEIBE		WASHER
3a	23	1	1	664794985		SCHRAUBE		SCREW
3a	24	1	1	664743000		GELENK		JOINT
3a	25	1	1	664785213		HALTER		SUPPORT
3a	26	2	2	664791213		SCHRAUBE		SCREW
3a	27	2	2	664521330		SCHEIBE		WASHER
3a	28	2	2	664154510		MUTTER		NUT
3a	29	1	1	664999539		LENKSTAB		ROD
3a	30	2	2	664523070		SCHEIBE		WASHER
3a	31	2	2	664155010		MUTTER		NUT
3a	41	1	1	664034024		KIPPHEBEL KPL.	INC. 42,43	EQUALIZER
3a	42	4	4	664034002		BUCHSE		BUSH
3a	43	2	2	664379511		FETTBUCHSE		GREASE DISPENSER
3a	44	1	1	664600161		DISTANZRING		SPACER
3a	45	1	1	664692695		SCHRAUBE		SCREW
3a	46	2	2	664523100		SCHEIBE		WASHER
3a	47	1	1	664587100		FEDERRING		GROWER
3a	48	1	1	664295300		MUTTER		NUT
3a	49	1	1	664230363		ACHSSCHENKEL RECHTS		STUB AXLE RIGHT
3a	50	1	1	664230365		ACHSSCHENKEL LINKS		STUB AXLE LEFT
3a	51	2	2	664001000		SPRENGRING		SNAP RING
3a	52	1	1	664743000		GELENK		JOINT
3a	53	1	1	664785213		HALTER		SUPPORT
3a	54	2	2	664791213		SCHRAUBE		SCREW
3a	55	2	2	664521330		SCHEIBE		WASHER

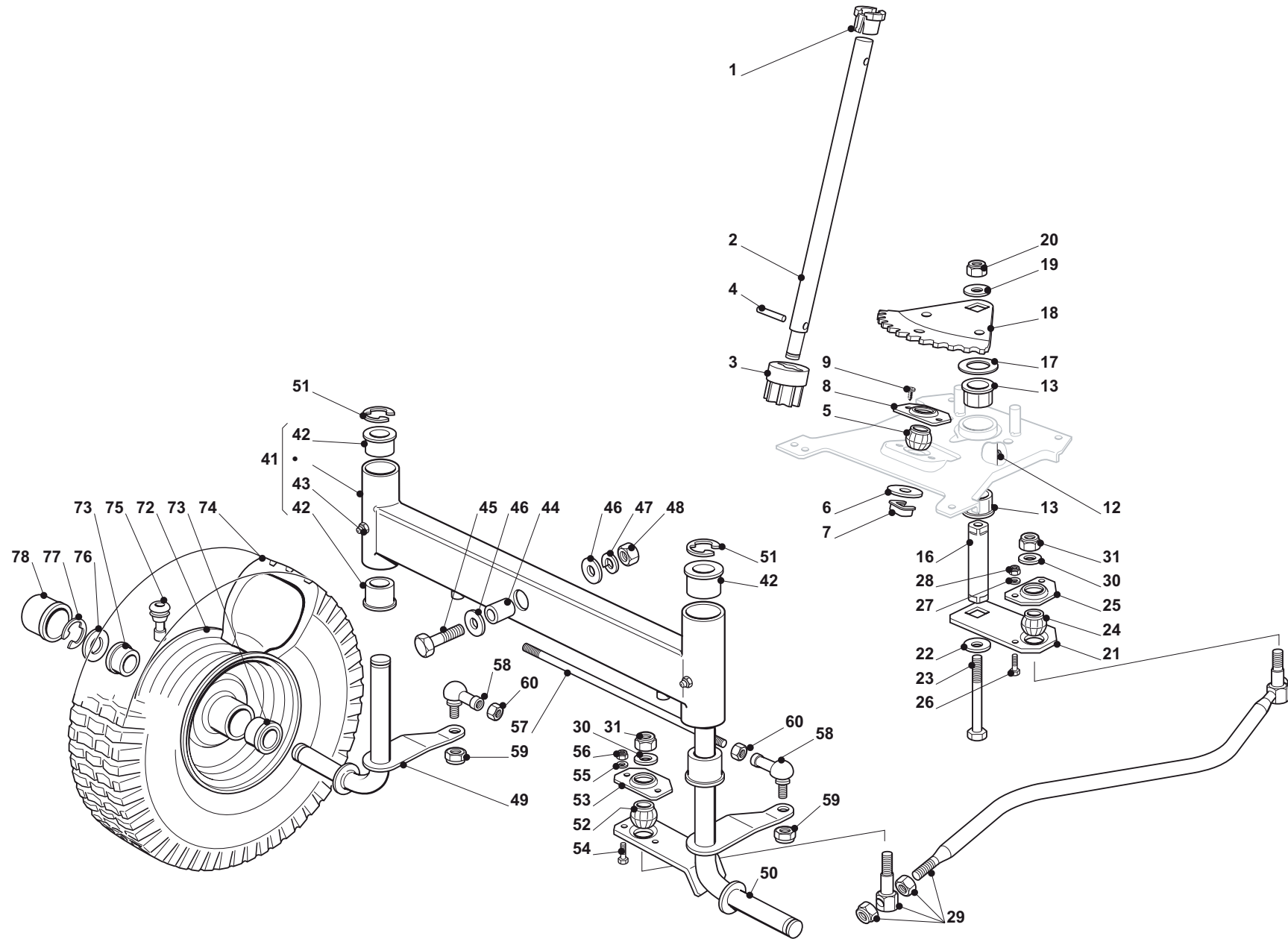

TM-92.14 (2015), TM-92.14 H
(2015)

3a

LENKGETRIEBE
STEERING



Seite / Page	Pos.	TM-92.14 (2015)	TM-92.14 H (2015)	Teil-Nr. Part No.	Hinweise Notes	Bezeichnung	Spezifikation Specification	Description
3a	56	2	2	664154510		MUTTER		NUT
3a	57	1	1	664840023		SPANNSTANGE		TIE ROD
3a	58	2	2	664746609		GELENK		JOINT
3a	59	2	2	664156602		MUTTER		NUT
3a	60		2	664295201		MUTTER		NUT
3a	72	2	2	664000598		VORDERRAD FELGE		RIMM
3a	73	4	4	664122210		LAGER		BEARING
3a	74	2	2	664590019		REIFEN		TYRE
3a	75	2	2	664950000		VENTIL		VALVE
3a	76	2	2	664670005		SCHEIBE		WASHER
3a	77	2	2	664001000		SPRENGRING		SNAP RING
3a	78	2	2	664110230		NABENDECKEL		HUB COVER

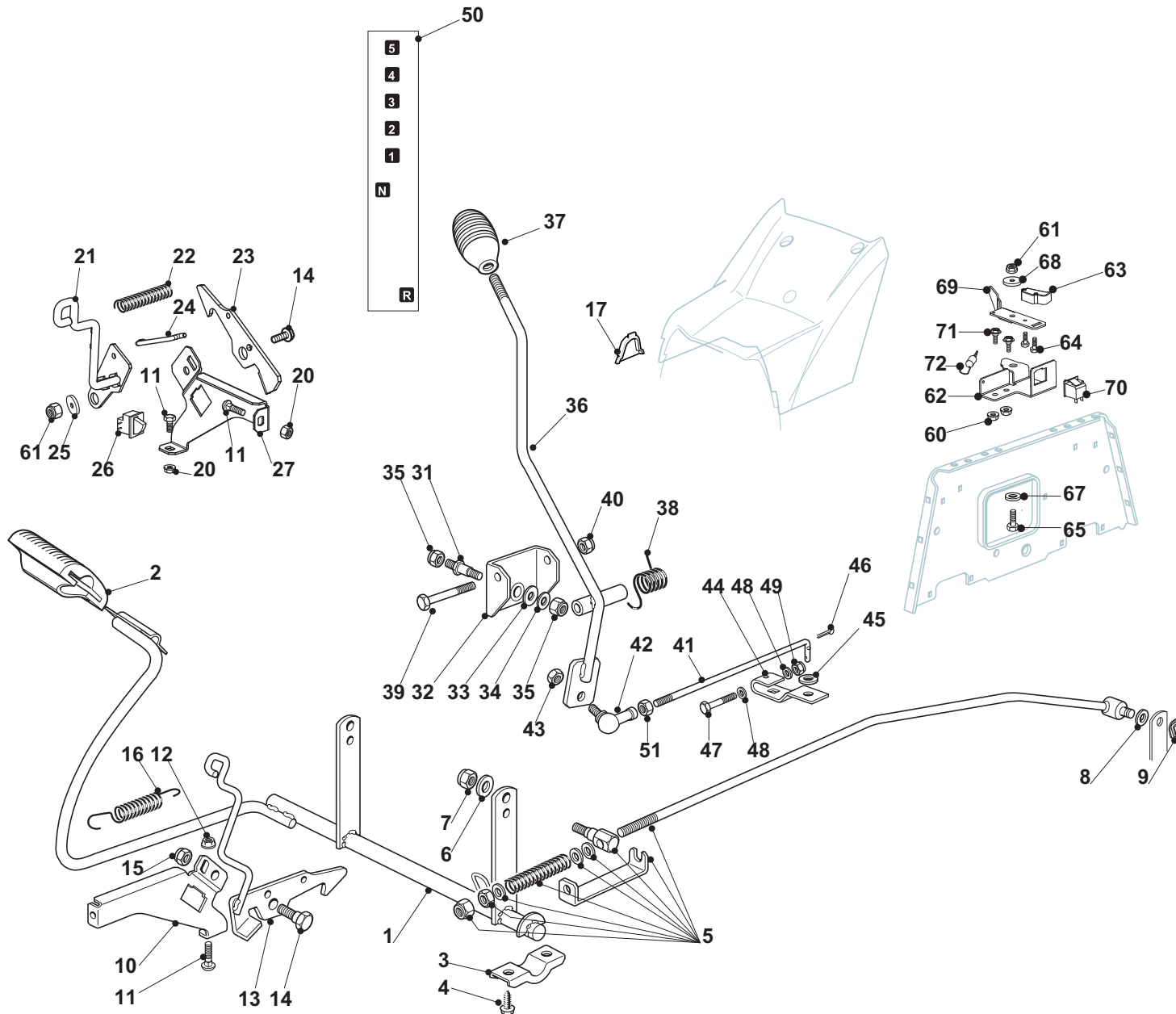

Seite / Page	Pos.	TM-92.14 (2015)	Teil-Nr. Part No.	Hinweise Notes	Bezeichnung	Spezifikation Specification	Description
4m	1	1	664999027		PEDAL		PEDAL
4m	2	1	664028527		PEDALGUMMI		PEDAL PAD
4m	3	2	664546015		PLATTE		PLATE
4m	4	4	664729601		SCHRAUBE		SCREW
4m	5	1	664000541		STANGE	Peerless	ROD
4m	6	1	664523040		SCHEIBE		WASHER
4m	7	1	664154510		MUTTER		NUT
4m	8	1	664521350		SCHEIBE		WASHER
4m	9	1	664436050		PLATTE		PLATE
4m	10	1	664785261		HALTER		SUPPORT
4m	11	2	664815200		SCHRAUBE		SCREW
4m	12	2	664292102		MUTTER		NUT
4m	13	1	664028528		BREMSHEBEL		BRAKE LEVER
4m	14	1	664524970		BOLZEN		PIN
4m	15	1	664155000		MUTTER		NUT
4m	16	1	664430213		FEDER		SPRING
4m	17	1	664207172		PLATTE		PLATE
4m	20	4	664292102		MUTTER		NUT
4m	21	1	664028528		BREMSHEBEL		BRAKE LEVER
4m	22	1	664430213		FEDER		SPRING
4m	23	1	664028529		BREMSHAKEN		BRAKE HOOK
4m	24	1	664028530		STANGE		ROD
4m	25	1	664041980		BUCHSE		BUSH
4m	26	1	664410613		MIKROSCHALTER		MICRO SWITCH
4m	27	1	664785261		HALTER		SUPPORT
4m	31	1	664510035		BOLZEN		PIN
4m	32	1	664774247		HALTER		BRACKET
4m	33	1	664672152		SCHEIBE		WASHER
4m	34	1	664523060		SCHEIBE		WASHER
4m	35	2	664155010		MUTTER		NUT
4m	36	1	664318215		HEBEL		LEVER
4m	37	1	664394510		GRIFF		KNOB
4m	38	1	664430258		FEDER		SPRING
4m	39	1	664692050		SCHRAUBE		SCREW
4m	40	1	664155000		MUTTER		NUT
4m	41	1	664033012		STANGE		ROD
4m	42	1	664746601		GELENK		JOINT
4m	43	1	664155000		MUTTER		NUT
4m	44	1	664318128		HEBEL		LEVER
4m	45	1	664521340		SCHEIBE		WASHER
4m	46	1	664141418		SPLINT		COTTER PIN
4m	47	1	664689500		SCHRAUBE		SCREW

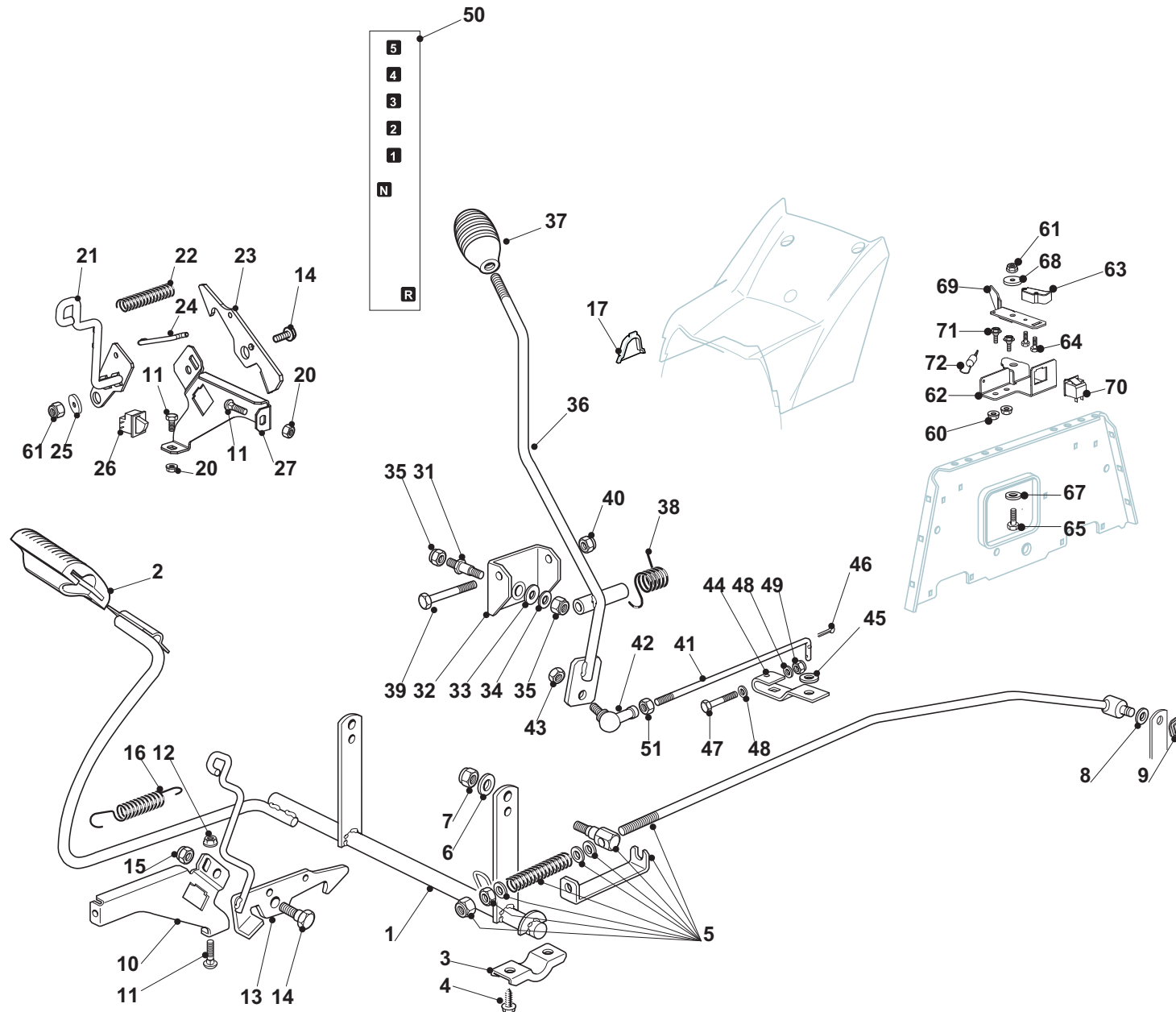

TM-92.14 (2015), TM-92.14 H
(2015)

4m

GETRIEBE UND BREMSE ANTRIEB
DRIVE AND BRAKE CONTROLS



Seite / Page	Pos.	TM-92.14 (2015)	Teil-Nr. Part No.	Hinweise Notes	Bezeichnung	Spezifikation Specification	Description
4m	48	2	664521330		SCHEIBE		WASHER
4m	49	1	664154510		MUTTER		NUT
4m	50	1	664361447		SCHILD, GANGSCHALTUNG		LABEL, SPEED DRIVE CONTROL
4m	51	1	664293200		MUTTER		NUT
4m	60	4	664293201		MUTTER		NUT
4m	61	2	664155010		MUTTER		NUT
4m	62	1	664028531		SCHALTERAUFNAHME		MICRO SWITCH BRACKET
4m	63	1	664028532		NOCKEN		CAM
4m	64	2	664028533		SCHRAUBE		SCREW
4m	65	1	664529662		BOLZEN		PIN
4m	67	1	664028534		SCHEIBE		WASHER
4m	68	1	664672152		SCHEIBE		WASHER
4m	69	1	664028535		HALTER		SUPPORT
4m	70	1	664410614		MIKROSCHALTER		MICRO SWITCH
4m	71	2	664028536		SCHRAUBE		SCREW
4m	72	1	664430213		FEDER		SPRING

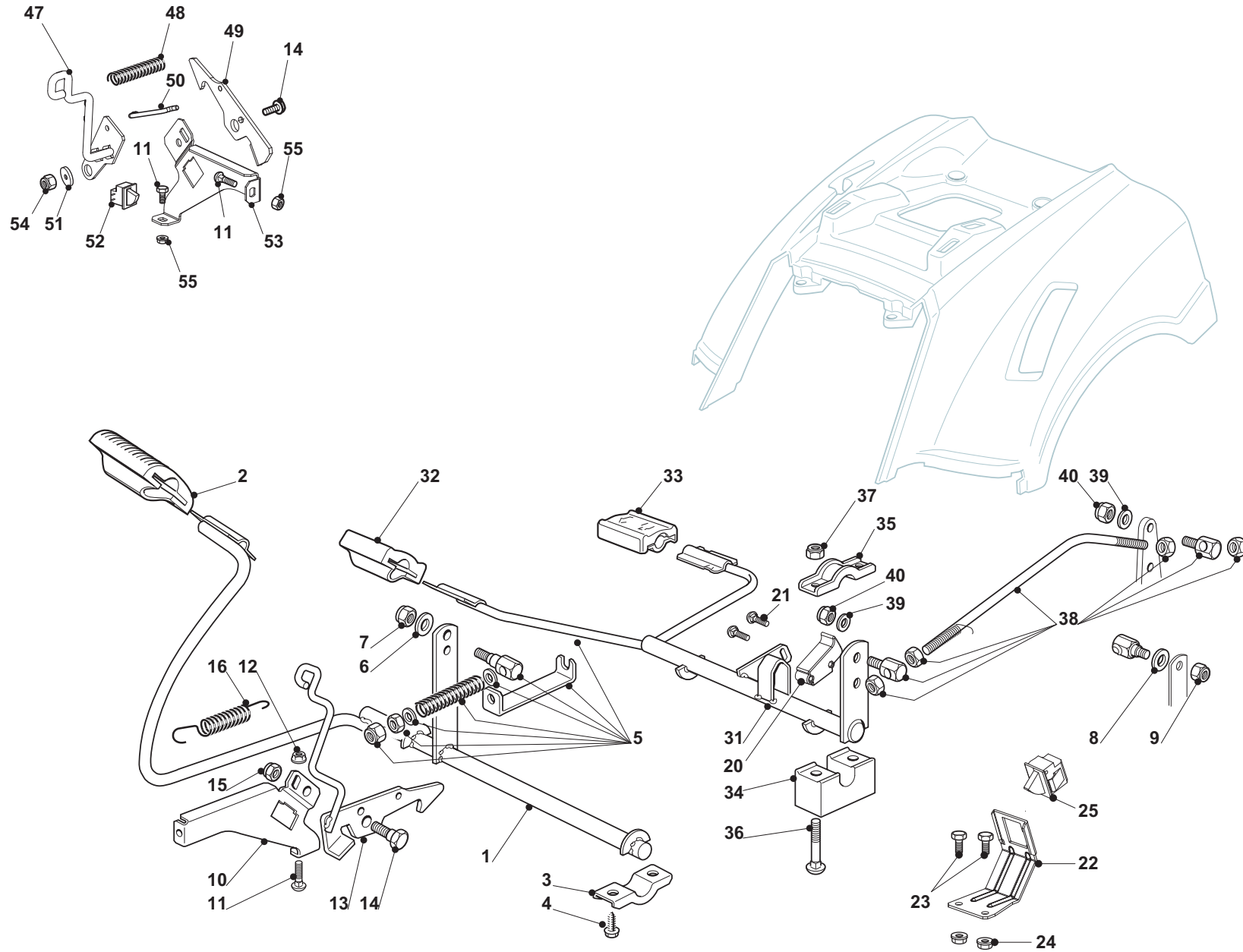

TM-92.14 (2015), TM-92.14 H
(2015)

4y

GETRIEBE UND BREMSE ANTRIEB
DRIVE AND BRAKE CONTROLS



Seite / Page	Pos.	TM-92.14 H (2015)	Teil-Nr. Part No.	Hinweise Notes	Bezeichnung	Spezifikation Specification	Description
4y	1	1	664999029		PEDAL		PEDAL
4y	2	1	664110416		PEDALGUMMI		PEDAL PAD
4y	3	2	664546015		PLATTE		PLATE
4y	4	4	664729601		SCHRAUBE		SCREW
4y	5	1	664000542		STANGE		ROD
4y	6	1	664521350		SCHEIBE		WASHER
4y	7	1	664155000		MUTTER		NUT
4y	8	1	664521350		SCHEIBE		WASHER
4y	9	1	664155000		MUTTER		NUT
4y	10	1	664785261		HALTER		SUPPORT
4y	11	2	664815200		SCHRAUBE		SCREW
4y	12	2	664292102		MUTTER		NUT
4y	13	1	664028528		BREMSHEBEL		BRAKE LEVER
4y	14	1	664524970		BOLZEN		PIN
4y	15	1	664155000		MUTTER		NUT
4y	16	1	664430213		FEDER		SPRING
4y	20	1	664028532		NOCKEN		CAM
4y	21	2	664028533		SCHRAUBE		SCREW
4y	22	1	664028537		PLATTE		PLATE
4y	23	2	664793102		SCHRAUBE		SCREW
4y	24	2	664293201		MUTTER		NUT
4y	25	1	664410614		MIKROSCHALTER		MICRO SWITCH
4y	31	1	664028538		GETRIEBEPEDAL		DRIVE PEDAL
4y	32	1	664110417		PEDALGUMMI		PEDAL PAD
4y	33	1	664511041		PEDALGUMMI		PEDAL PAD
4y	34	2	664785185		HALTER		SUPPORT
4y	35	2	664546015		PLATTE		PLATE
4y	36	4	664815245		SCHRAUBE		SCREW
4y	37	4	664154510		MUTTER		NUT
4y	38	1	664000543		STANGE		ROD
4y	39	2	664523040		SCHEIBE		WASHER
4y	40	2	664154510		MUTTER		NUT
4y	47	1	664028528		BREMSHEBEL		BRAKE LEVER
4y	48	1	664430213		FEDER		SPRING
4y	49	1	664028529		BREMSSHAKEN		BRAKE HOOK
4y	50	1	664028530		STANGE		ROD
4y	51	1	664041980		BUCHSE		BUSH
4y	52	1	664410613		MIKROSCHALTER		MICRO SWITCH
4y	53	1	664785261		HALTER		SUPPORT
4y	54	1	664155010		MUTTER		NUT
4y	55	4	664292102		MUTTER		NUT

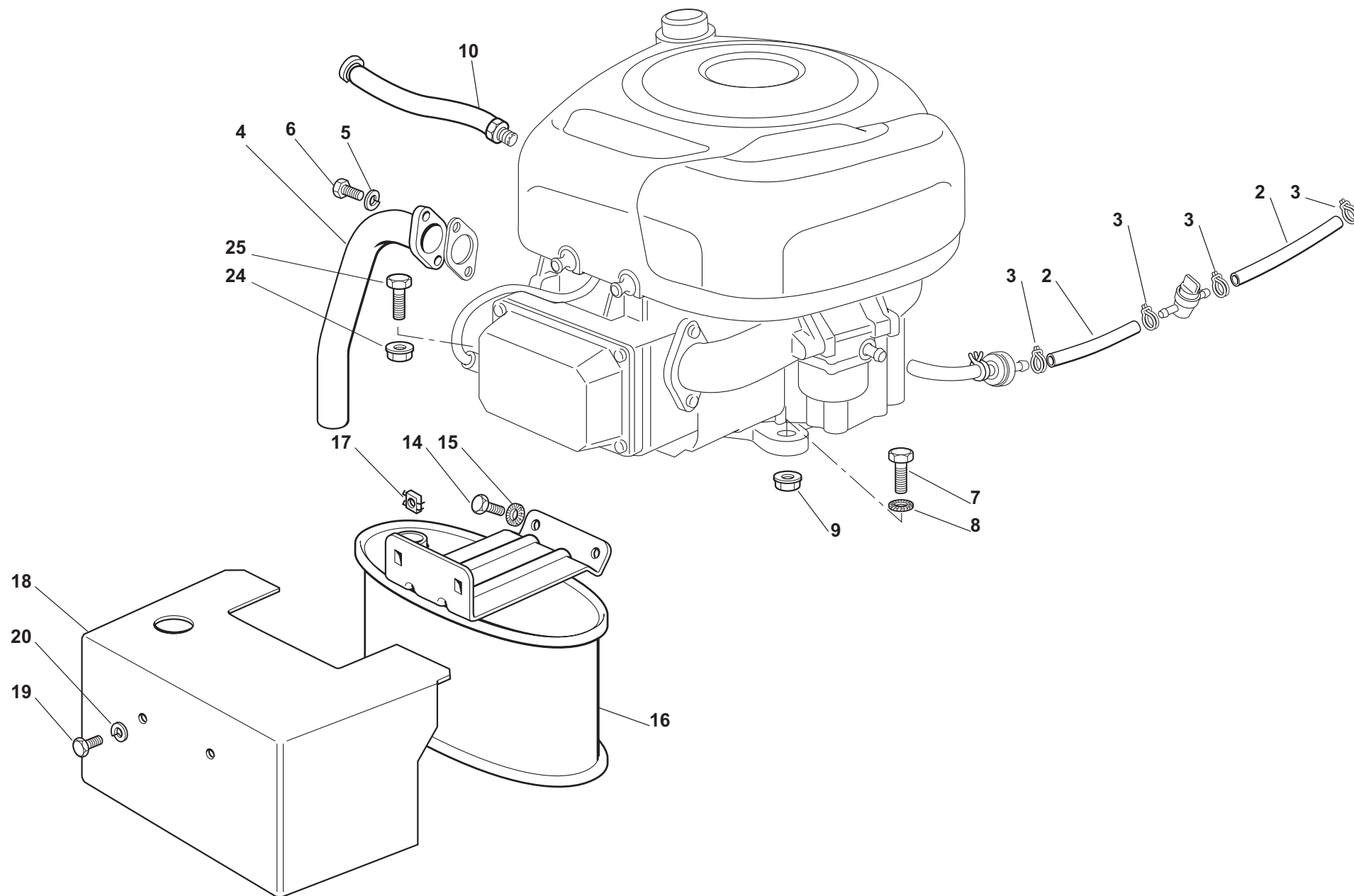

TM-92.14 (2015), TM-92.14 H
(2015)

5

Motor
Motor



Seite / Page	Pos.	TM-92.14 (2015)	TM-92.14 H (2015)	Teil-Nr. Part No.	Hinweise Notes	Bezeichnung	Spezifikation Specification	Description
5	2	1	1	664869057		VERBINDUNGSROHR		TUBE
5	3	4	4	664375051		SCHLAUCHKLEMME		HOSE CLAMP
5	4	1	1	664738224		ABGASROHR		TUBE
5	5	2	2	664583500		FEDERRING		GROWER
5	6	2	2	664735530		SCHRAUBE		SCREW
5	7	1	1	664691115		SCHRAUBE		SCREW
5	8	1	1	664540260		SCHEIBE		WASHER
5	9	1	1	664154210		MUTTER		NUT
5	10	1	1	664345827		ÖLABFLUSS		OIL DISCHARGE EXTENSION
5	14	2	2	664793102		SCHRAUBE		SCREW
5	15	2	2	664540260		SCHEIBE		WASHER
5	16	1	1	664750010		SCHALLDÄMPFER		MUFFLER
5	17	2	2	664360425		MUTTER		NUT
5	18	1	1	664598009		SCHUTZ		PROTECTION
5	19	2	2	664792611		SCHRAUBE		SCREW
5	20	2	2	664583500		FEDERRING		GROWER
5	24	3	3	664154210		MUTTER		NUT
5	25	3	3	664691100		SCHRAUBE		SCREW

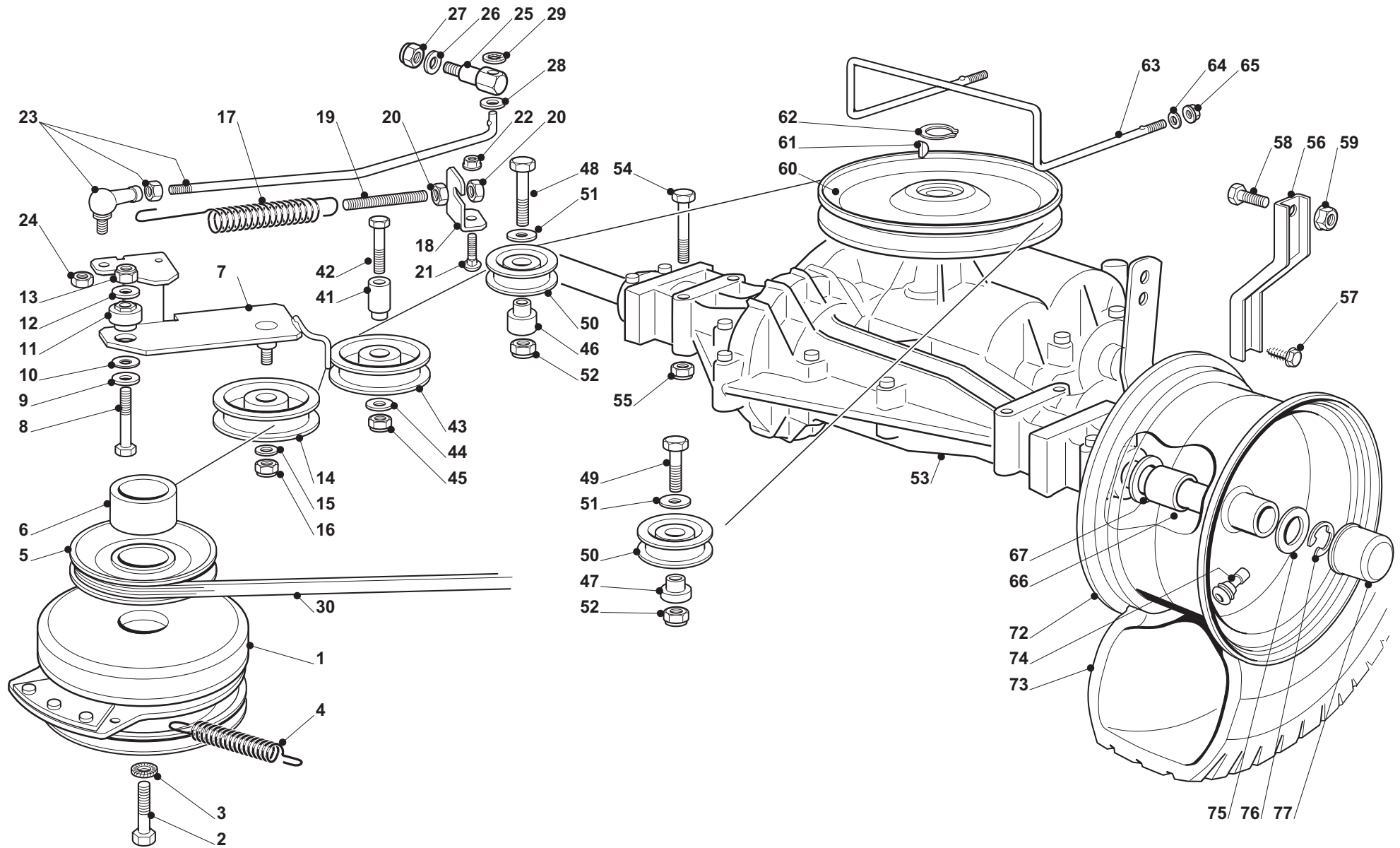

Seite / Page	Pos.	TM-92.14 (2015)	Teil-Nr. Part No.	Hinweise Notes	Bezeichnung	Spezifikation Specification	Description
6m	1	1	664399063		KUPPLUNG		CLUTCH
6m	2	1	664737320		SCHRAUBE		SCREW
6m	3	1	664543000		SCHEIBE		WASHER
6m	4	1	664430216		FEDER		SPRING
6m	5	1	664601567		RIEMENSCHLEIBE		PULLEY
6m	6	1	664600590		DISTANZBUCHSE		SPACER
6m	7	1	664318217		HEBEL		LEVER
6m	8	1	664691115		SCHRAUBE		SCREW
6m	9	1	664523060		SCHEIBE		WASHER
6m	10	1	664670055		SCHEIBE		WASHER
6m	11	1	664510087		BOLZEN		PIN
6m	12	1	664523060		SCHEIBE		WASHER
6m	13	1	664155000		MUTTER		NUT
6m	14	1	664601554		RIEMENSCHLEIBE		PULLEY
6m	15	1	664523060		SCHEIBE		WASHER
6m	16	1	664155000		MUTTER		NUT
6m	17	1	664430260		FEDER		SPRING
6m	18	1	664755049		WINKEL		BRACKET
6m	19	1	664840005		SPANNSTANGE		TIE ROD
6m	20	2	664293200		MUTTER		NUT
6m	21	1	664818690		SCHRAUBE		SCREW
6m	22	1	664293201		MUTTER		NUT
6m	23	1	664820013		SPANNSTANGE KPL.		TIE ROD ASSY.
6m	24	1	664155000		MUTTER		NUT
6m	25	1	664510063		BOLZEN		PIN
6m	26	2	664670011		SCHEIBE		WASHER
6m	27	1	664155000		MUTTER		NUT
6m	28	1	664521350		SCHEIBE		WASHER
6m	29	1	664604899		SICHERUNGSSCHLEIBE		SAFETY WASHER
6m	30	1	664062012		RIEMEN		BELT
6m	41	1	664028540		BOLZEN		PIN
6m	42	1	664691800		SCHRAUBE		SCREW
6m	43	1	664028523		RIEMENSCHLEIBE		PULLEY
6m	44	1	664523060		SCHEIBE		WASHER
6m	45	1	664155000		MUTTER		NUT
6m	46	1	664160014		DISTANZSTÜCK RECHTS		SPACER
6m	47	1	664160018		DISTANZSTÜCK LINKS		SPACER LEFT
6m	48	1	664691200		SCHRAUBE		SCREW
6m	49	1	664691100		SCHRAUBE		SCREW
6m	50	2	664601588		RIEMENSCHLEIBE		PULLEY
6m	51	2	664671653		SCHEIBE		WASHER
6m	52	2	664155000		MUTTER		NUT

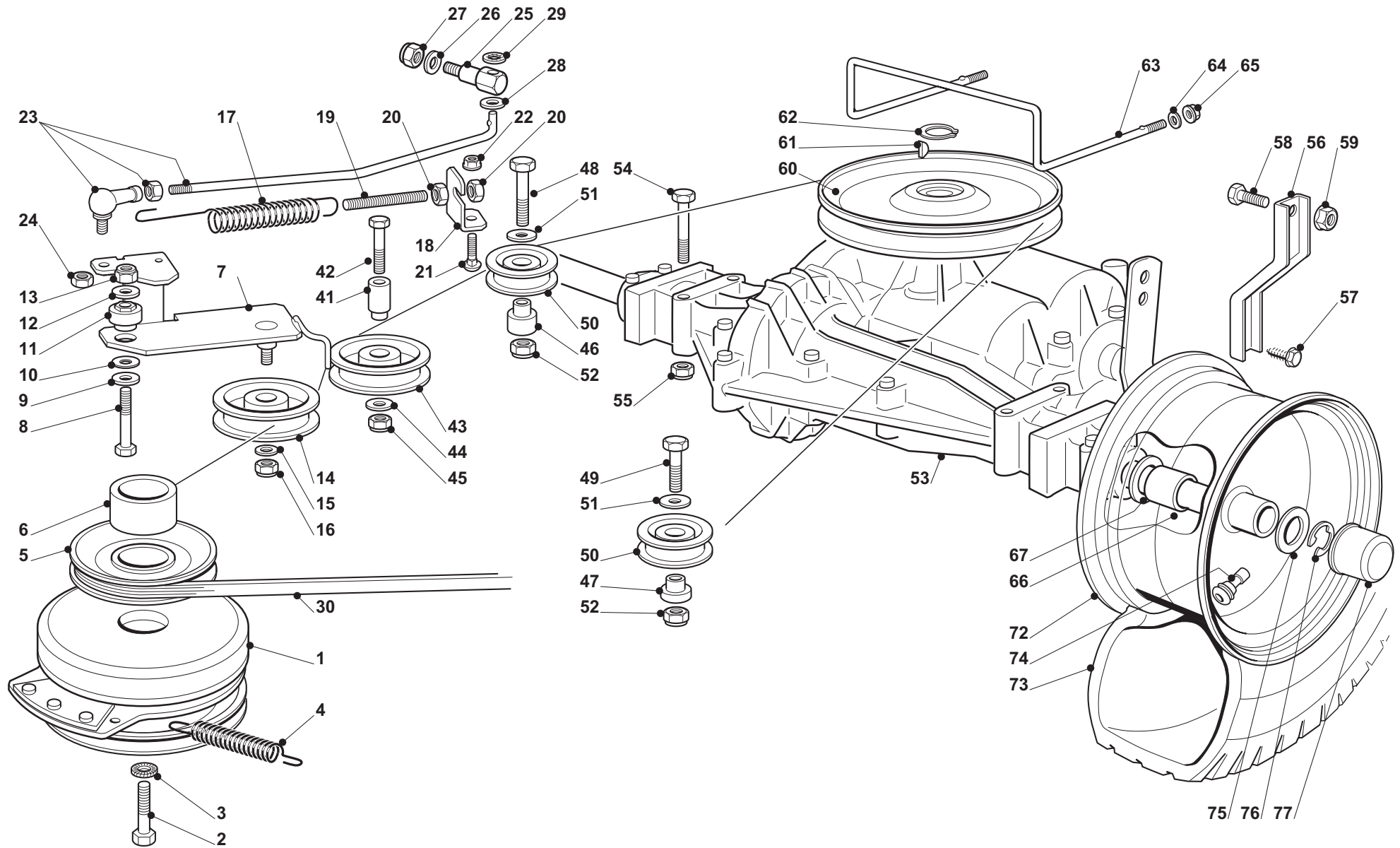

TM-92.14 (2015), TM-92.14 H
(2015)

6m

Getriebe
Gear



Seite / Page	Pos.	TM-92.14 (2015)	Teil-Nr. Part No.	Hinweise Notes	Bezeichnung	Spezifikation Specification	Description
6m	53	1	664400910		HINTERACHSE		REAR AXLE
6m	54	4	664691800		SCHRAUBE		SCREW
6m	55	4	664154210		MUTTER		NUT
6m	56	2	664999247		HALTER		BRACKET
6m	57	2	664735150		SCHRAUBE		SCREW
6m	58	2	664792611		SCHRAUBE		SCREW
6m	59	2	664293201		MUTTER		NUT
6m	60	1	664601509		RIEMENSCHLEIBE		PULLEY
6m	61	1	664139430		KEIL		KEY
6m	62	1	664608950		SPRENGRING		SNAP RING
6m	63	1	664270321		RIEMENFÜHRUNG		BELT GUIDE
6m	64	2	664523040		SCHEIBE		WASHER
6m	65	2	664292102		MUTTER		NUT
6m	66	2	664160031		DISTANZBUCHSE		SPACER
6m	67	2-4	664521410		SCHEIBE		WASHER
6m	72	2	664000599		HINTERRAD FELGE		RIMM
6m	73	2	664590015		REIFEN		TYRE
6m	74	2	664950000		VENTIL		VALVE
6m	75	2	664670005		SCHEIBE		WASHER
6m	76	2	664001010		SPRENGRING		SNAP RING
6m	77	2	664110230		NABENDECKEL		HUB COVER

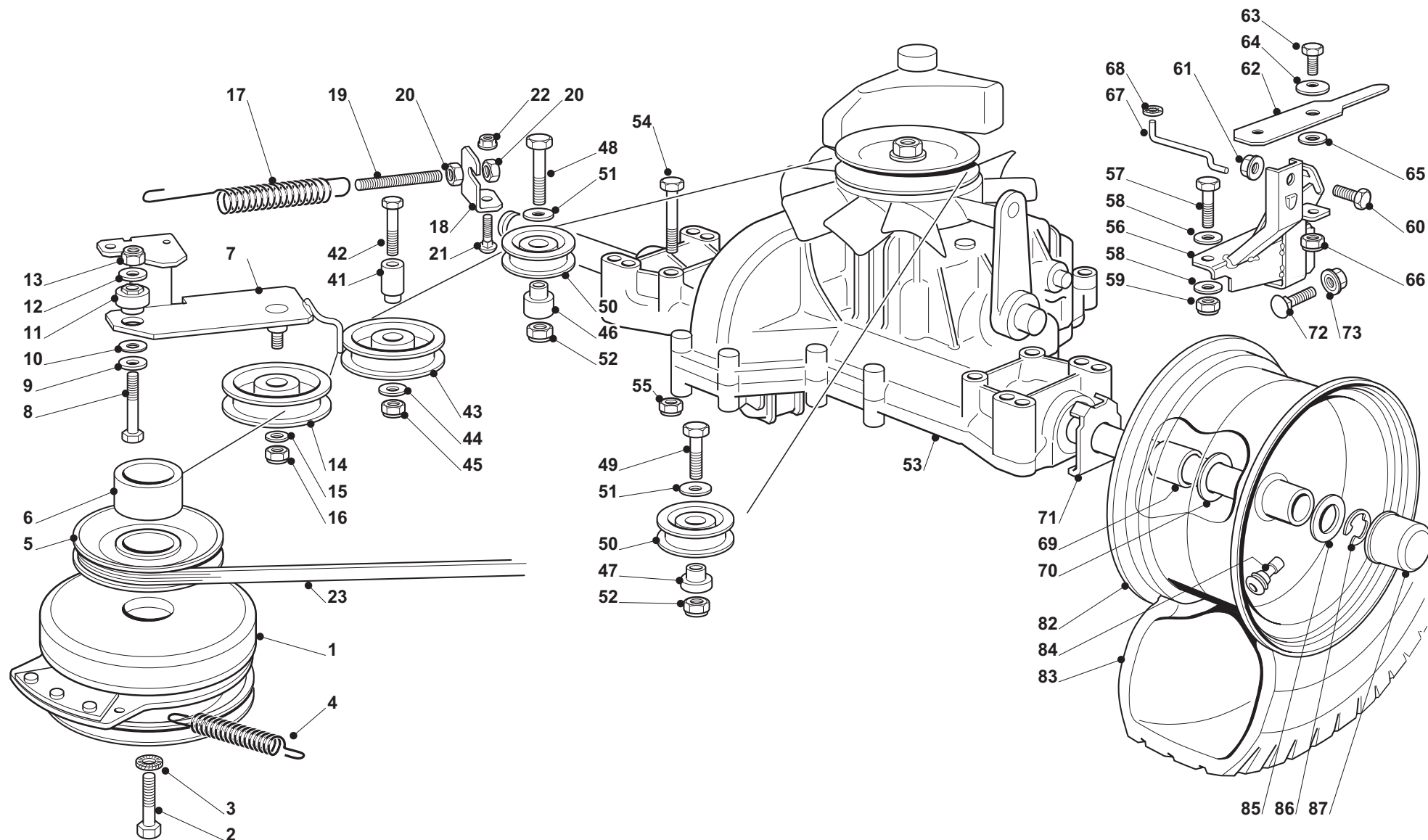

Seite / Page	Pos.	Teil-Nr. Part No.	Hinweise Notes	Bezeichnung	Spezifikation Specification	Description
6y	1	664399063		KUPPLUNG		CLUTCH
6y	2	664737320		SCHRAUBE		SCREW
6y	3	664543000		SCHEIBE		WASHER
6y	4	664430216		FEDER		SPRING
6y	5	664601566		RIEMENSCHLEIBE		PULLEY
6y	6	664600590		DISTANZBUCHSE		SPACER
6y	7	664318217		HEBEL		LEVER
6y	8	664691115		SCHRAUBE		SCREW
6y	9	664523060		SCHEIBE		WASHER
6y	10	664670055		SCHEIBE		WASHER
6y	11	664510087		BOLZEN		PIN
6y	12	664523060		SCHEIBE		WASHER
6y	13	664155000		MUTTER		NUT
6y	14	664601554		RIEMENSCHLEIBE		PULLEY
6y	15	664523060		SCHEIBE		WASHER
6y	16	664155000		MUTTER		NUT
6y	17	664430260		FEDER		SPRING
6y	18	664755049		WINKEL		BRACKET
6y	19	664840005		SPANNSTANGE		TIE ROD
6y	20	664293200		MUTTER		NUT
6y	21	664818690		SCHRAUBE		SCREW
6y	22	664293201		MUTTER		NUT
6y	23	664028541		KEILRIEMEN		V-BELT
6y	41	664028540		BOLZEN		PIN
6y	42	664691800		SCHRAUBE		SCREW
6y	43	664028523		RIEMENSCHLEIBE		PULLEY
6y	44	664523060		SCHEIBE		WASHER
6y	45	664155000		MUTTER		NUT
6y	46	664160024		DISTANZSTÜCK RECHTS		SPACER
6y	47	664160030		DISTANZSTÜCK LINKS		SPACER
6y	48	664691400		SCHRAUBE		SCREW
6y	49	664691115		SCHRAUBE		SCREW
6y	50	664601588		RIEMENSCHLEIBE		PULLEY
6y	51	664671653		SCHEIBE		WASHER
6y	52	664155000		MUTTER		NUT
6y	53	664400960		HINTERACHSE KPL.	Tuff-Torq K46S	REAR AXLE ASSY.
6y	54	664691800		SCHRAUBE		SCREW
6y	55	664154210		MUTTER		NUT
6y	56	664999149		HALTER		SUPPORT
6y	57	664691200		SCHRAUBE		SCREW
6y	58	664521350		SCHEIBE		WASHER
6y	59	664155000		MUTTER		NUT

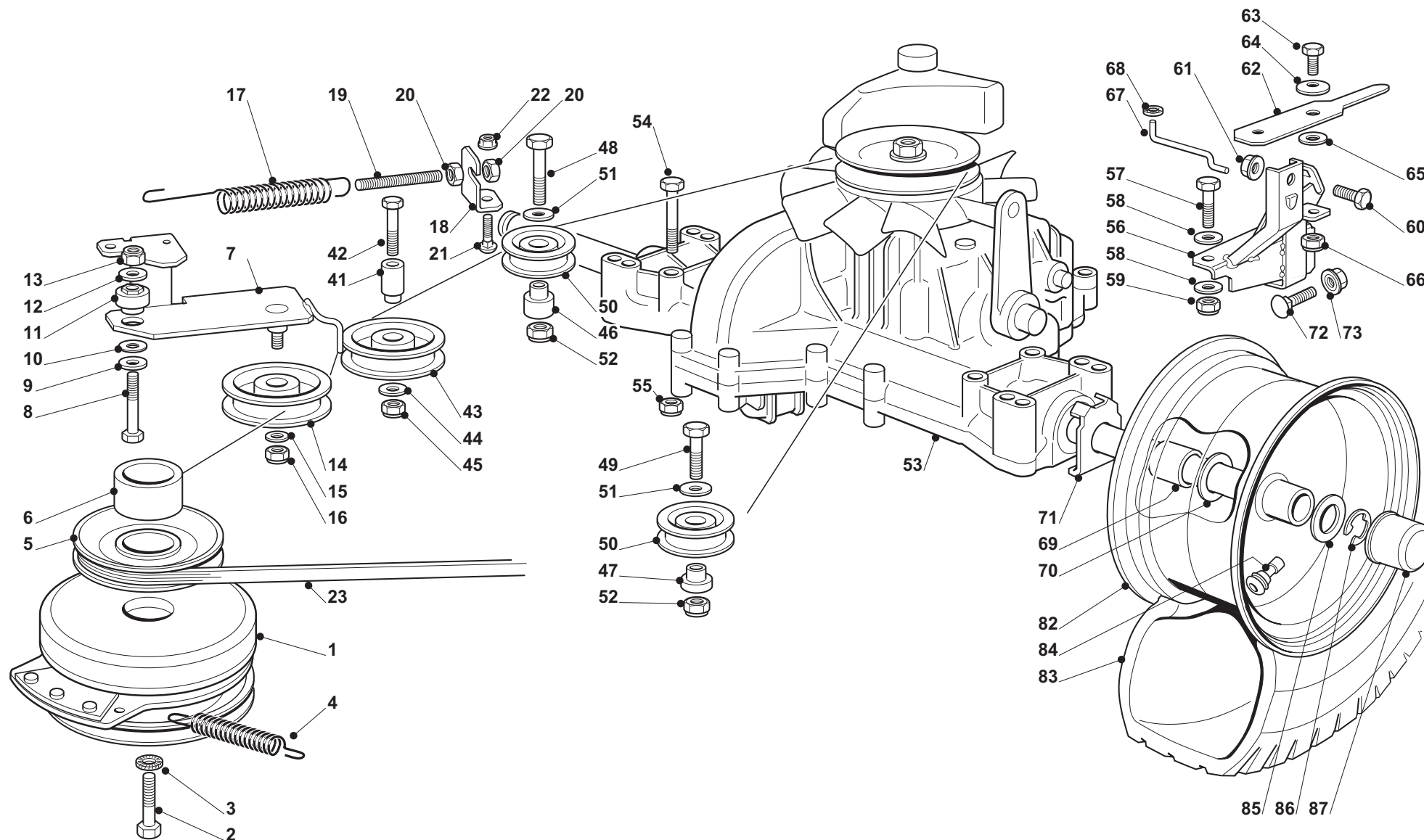

Seite / Page	Pos.	TM-92.14 H (2015)	Teil-Nr. Part No.	Hinweise Notes	Bezeichnung	Spezifikation Specification	Description
6y	60	1	664792611		SCHRAUBE		SCREW
6y	61	1	664293201		MUTTER		NUT
6y	62	1	664318157		HEBEL		LEVER
6y	63	1	664793102		SCHRAUBE		SCREW
6y	64	1	664369500		FEDERSCHEIBE		ELASTIC WASHER
6y	65	1	664670011		SCHEIBE		WASHER
6y	66	1	664155000		MUTTER		NUT
6y	67	1	664033033		STANGE		ROD
6y	68	1	664604896		SICHERUNGSSCHEIBE		SAFETY WASHER
6y	69	2	664160031		DISTANZBUCHSE		SPACER
6y	70	2-4	664521410		SCHEIBE		WASHER
6y	71	2	664670025		SCHEIBE		WASHER
6y	72	1	664792611		SCHRAUBE		SCREW
6y	73	1	664293201		MUTTER		NUT
6y	82	2	664000599		HINTERRAD FELGE		RIMM
6y	83	2	664590015		REIFEN		TYRE
6y	84	2	664950000		VENTIL		VALVE
6y	85	2	664670005		SCHEIBE		WASHER
6y	86	2	664001010		SPRENGRING		SNAP RING
6y	87	2	664110230		NABENDECKEL		HUB COVER

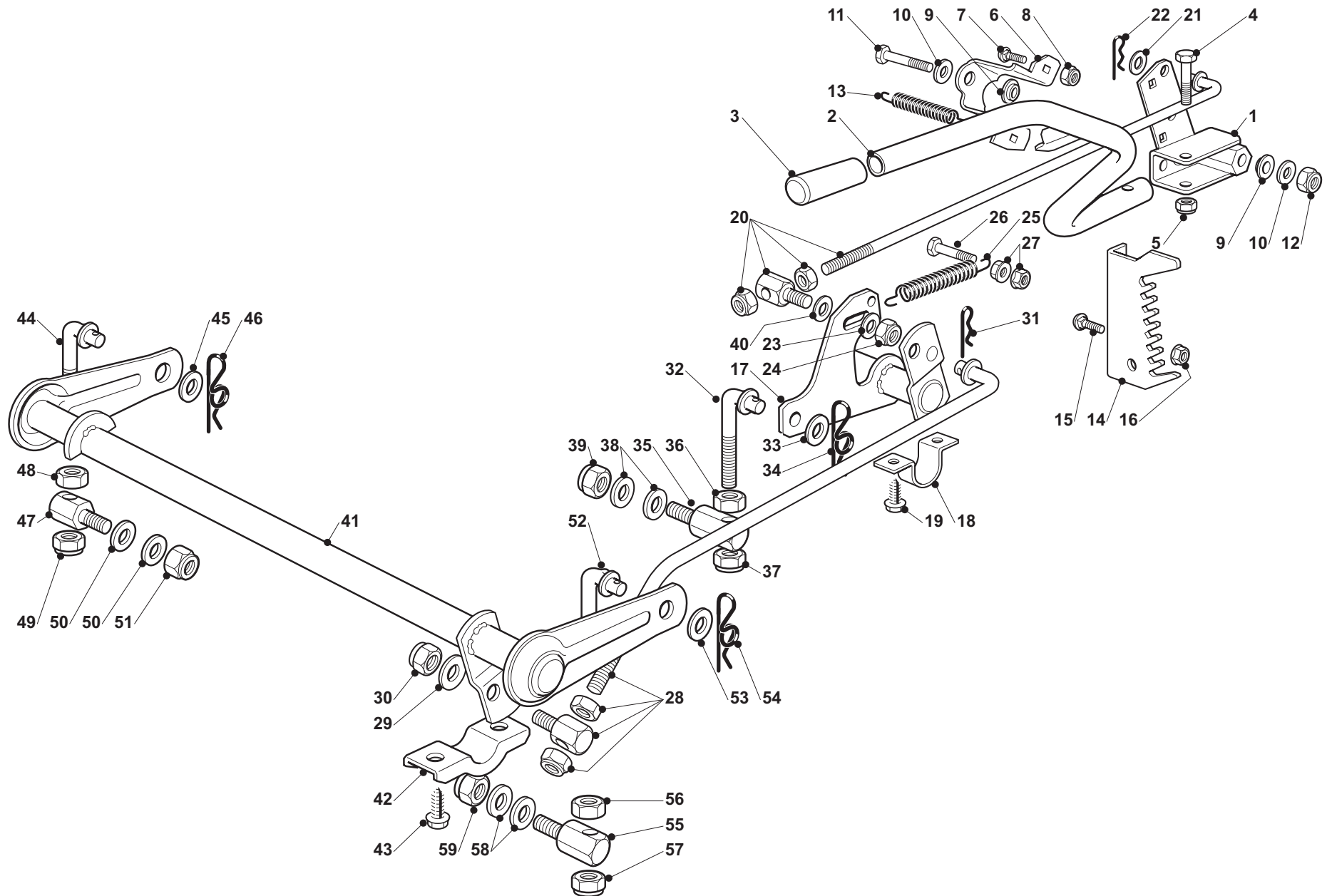



Seite / Page	Pos.	TM-92.14 (2015)	TM-92.14 H (2015)	Teil-Nr. Part No.	Hinweise Notes	Bezeichnung	Spezifikation Specification	Description
7	1	1	1	664774249		HALTER		BRACKET
7	2	1	1	664318219		HEBEL		LEVER
7	3	1	1	664394535		GRIFF		HANDLE
7	4	1	1	664674700		SCHRAUBE		SCREW
7	5	1	1	664154510		MUTTER		NUT
7	6	1	1	664650113		PLATTE		PLATE
7	7	2	2	664818690		SCHRAUBE		SCREW
7	8	2	2	664155000		MUTTER		NUT
7	9	2	2	664041980		BUCHSE		BUSH
7	10	2	2	664523060		SCHEIBE		WASHER
7	11	1	1	664691600		SCHRAUBE		SCREW
7	12	1	1	664155000		MUTTER		NUT
7	13	1	1	664430259		FEDER		SPRING
7	14	1	1	664735511		SEKTOR		SECTOR
7	15	2	2	664818690		SCHRAUBE		SCREW
7	16	2	2	664293201		MUTTER		NUT
7	17	1	1	664000387		ACHSE		AXLE
7	18	2	2	664547041		PLATTE		PLATE
7	19	4	4	664731580		SCHRAUBE		SCREW
7	20	1	1	664000618		STAB		ROD
7	21	1	1	664670011		SCHEIBE		WASHER
7	22	1	1	664487997		SPLINT		COTTER PIN
7	23	1	1	664670008		SCHEIBE		WASHER
7	24	1	1	664154210		MUTTER		NUT
7	25	1	1	664446402		FEDER		SPRING
7	26	1	1	664792410		SCHRAUBE		SCREW
7	27	2	2	664292102		MUTTER		NUT
7	28	1	1	664000537		VERBINDUNGSSTAB		CONNECTING ROD
7	29	2	2	664670008		SCHEIBE		WASHER
7	30	1	1	664156602		MUTTER		NUT
7	31	1	1	664487998		SPLINT		COTTER PIN
7	32	1	1	664840025		SPANNSTANGE		TIE ROD
7	33	1	1	664670008		SCHEIBE		WASHER
7	34	1	1	664487998		SPLINT		COTTER PIN
7	35	1	1	664510090		BOLZEN		PIN
7	36	1	1	664295200		MUTTER		NUT
7	37	1	1	664156602		MUTTER		NUT
7	38	2	2	664670008		SCHEIBE		WASHER
7	39	1	1	664156602		MUTTER		NUT
7	40	2	2	664521360		SCHEIBE		WASHER
7	41	1	1	664000385		ACHSE		AXLE
7	42	2	2	664546015		PLATTE		PLATE

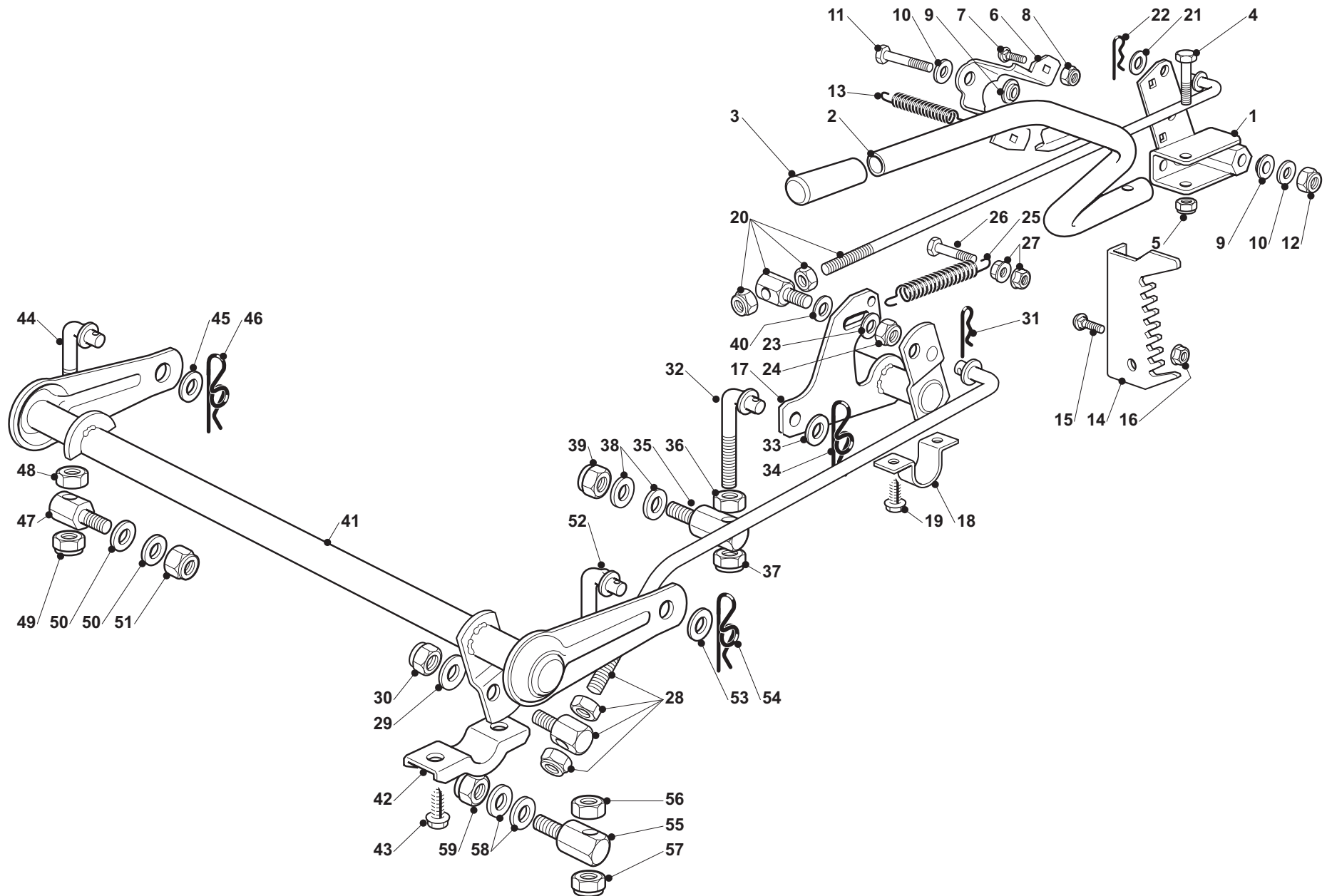



Seite / Page	Pos.	TM-92.14 (2015)	TM-92.14 H (2015)	Teil-Nr. Part No.	Hinweise Notes	Bezeichnung	Spezifikation Specification	Description
7	43	4	4	664731350		SCHRAUBE		SCREW
7	44	1	1	664840025		SPANNSTANGE		TIE ROD
7	45	1	1	664670008		SCHEIBE		WASHER
7	46	1	1	664487998		SPLINT		COTTER PIN
7	47	1	1	664640807		BOLZEN MIT SPANNSTANGE	INC. 44,48,49	BOLT WITH TIE ROD
7	48	1	1	664295200		MUTTER		NUT
7	49	1	1	664156602		MUTTER		NUT
7	50	2	2	664670008		SCHEIBE		WASHER
7	51	1	1	664156602		MUTTER		NUT
7	52	1	1	664840025		SPANNSTANGE		TIE ROD
7	53	1	1	664670008		SCHEIBE		WASHER
7	54	1	1	664487998		SPLINT		COTTER PIN
7	55	1	1	664510090		BOLZEN		PIN
7	56	1	1	664295200		MUTTER		NUT
7	57	1	1	664156602		MUTTER		NUT
7	58	2	2	664670008		SCHEIBE		WASHER
7	59	1	1	664156602		MUTTER		NUT

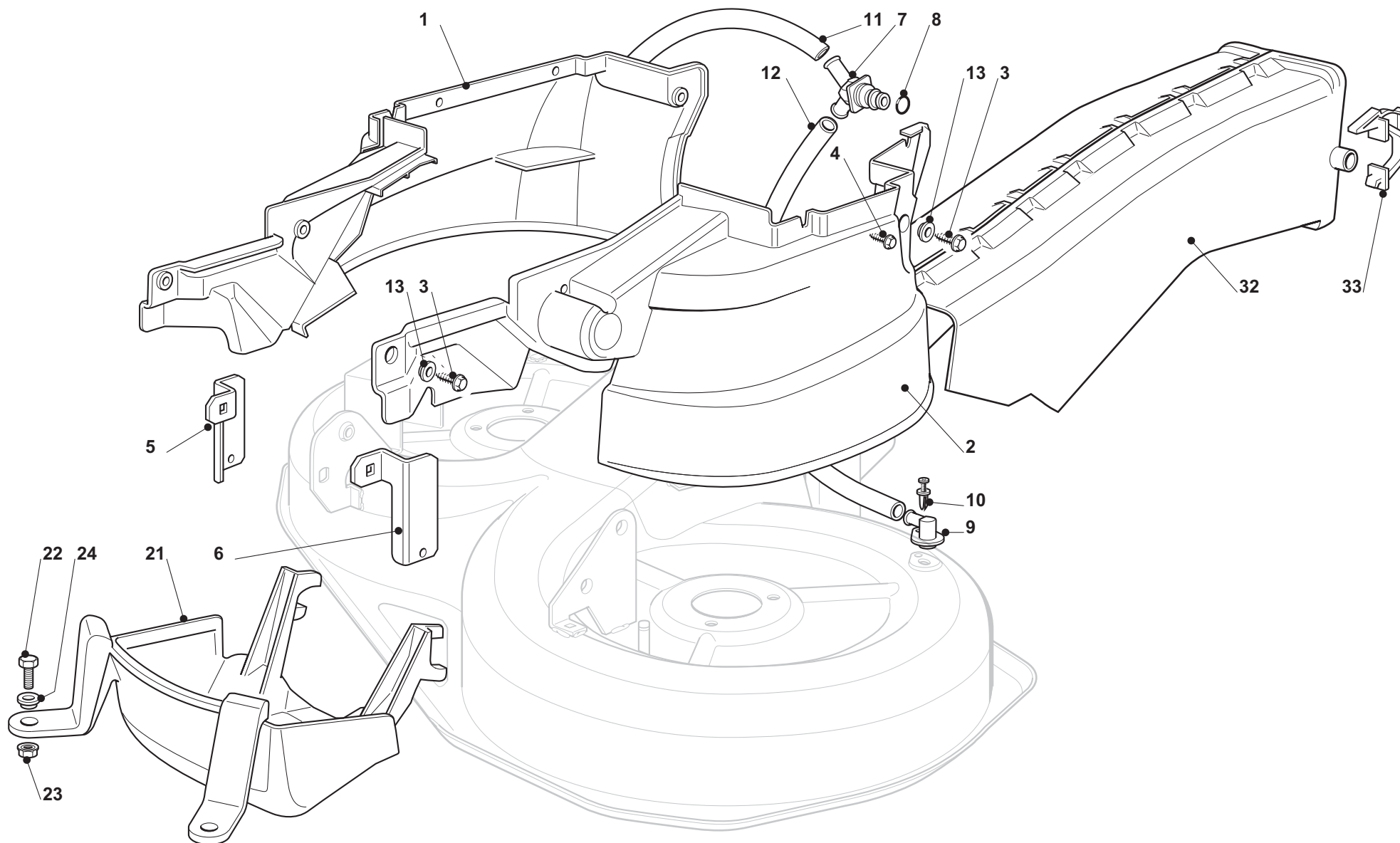

Seite / Page	Pos.	TM-92.14 (2015)	TM-92.14 H (2015)	Teil-Nr. Part No.	Hinweise Notes	Bezeichnung	Spezifikation Specification	Description
8	1	1	1	664028512		GEHÄUSE		CASE
8	2	1	1	664028513		GEHÄUSE		CASE
8	3	6	6	664735120		SCHRAUBE		SCREW
8	4	4	4	664028514		SCHRAUBE		SCREW
8	5	1	1	664028515		SCHELLE		BRACKET
8	6	1	1	664028516		SCHELLE		BRACKET
8	7	1	1	664028517		WASSERANSCHLUSS		WATER HOSE CONNECTION
8	8	1	1	664000970		SPRENGRING		SNAP RING
8	9	2	2	664028518		WASSERANSCHLUSS		WATER HOSE CONNECTION
8	10	2	2	664500030		NIET		RIVET
8	11	1	1	664028519		VERBINDUNGSROHR		CONNECTING TUBE
8	12	1	1	664028520		VERBINDUNGSROHR		CONNECTING TUBE
8	13	6	6	664160039		DISTANZSTÜCK		SPACER
8	21	1	1	664028521		GEHÄUSE		CASE
8	22	2	2	664791400		SCHRAUBE		SCREW
8	23	2	2	664154510		MUTTER		NUT
8	24	2	2	664160039		DISTANZSTÜCK		SPACER
8	32	1	1	664108008		AUSWURF BLECHSATZ KPL.		EXIT CONVEYOR A CPL.
8	33	2	2	664774373		HALTER		BRACKET

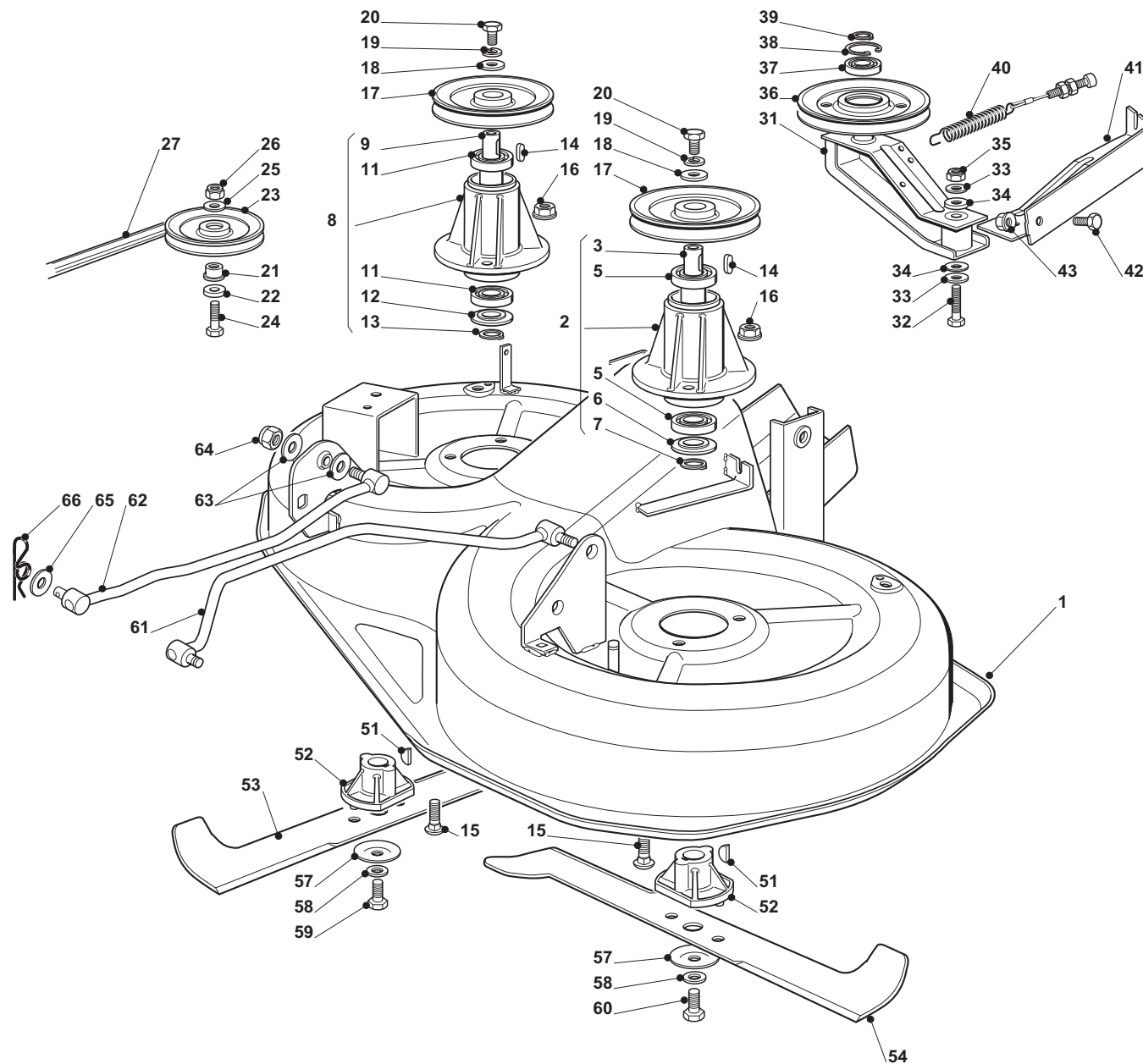



Seite / Page	Pos.	TM-92.14 (2015)	TM-92.14 H (2015)	Teil-Nr. Part No.	Hinweise Notes	Bezeichnung	Spezifikation Specification	Description
9	1	1	1	664564075		MÄHDECK		PLATE
9	2	1	1	664207202		NABE LINKS KPL.	INC. 3,5-7	FLANGE ASS.Y
9	3	1	1	664020802		WELLE		SHAFT
9	5	2	2	664216047		KUGELLAGER		BALL BEARING
9	6	1	1	664160501		STAUBSCHUTZSCHEIBE		DUST COVER
9	7	1	1	664609260		SICHERUNGSRING		RETAINING RING
9	8	1	1	664207203		NABE RECHTS KPL.	INC. 9,11-13	FLANGE ASS.Y
9	9	1	1	664020803		WELLE		SHAFT
9	11	2	2	664216047		KUGELLAGER		BALL BEARING
9	12	1	1	664160501		STAUBSCHUTZSCHEIBE		DUST COVER
9	13	1	1	664609260		SICHERUNGSRING		RETAINING RING
9	14	2	2	664139480		KEIL		KEY
9	15	6	6	664818700		SCHRAUBE		SCREW
9	16	6	6	664154210		MUTTER		NUT
9	17	2	2	664601563		RIEMENSCHLEIBE		PULLEY
9	18	2	2	664670007		SCHEIBE		WASHER
9	19	2	2	664583500		FEDERRING		GROWER
9	20	2	2	664793102		SCHRAUBE		SCREW
9	21	1	1	664028522		DISTANZBUCHSE		SPACER
9	22	1	1	664670007		SCHEIBE		WASHER
9	23	1	1	664028523		RIEMENSCHLEIBE		PULLEY
9	24	1	1	664691115		SCHRAUBE		SCREW
9	25	1	1	664523060		SCHEIBE		WASHER
9	26	1	1	664155000		MUTTER		NUT
9	27	1	1	664061508		KEILRIEMEN		V-BELT
9	31	1	1	664318141		HEBEL		LEVER
9	32	1	1	664691700		SCHRAUBE		SCREW
9	33	2	2	664523070		SCHEIBE		WASHER
9	34	2	2	664672152		SCHEIBE		WASHER
9	35	1	1	664155000		MUTTER		NUT
9	36	1	1	664601564		RIEMENSCHLEIBE		PULLEY
9	37	1	1	664216048		KUGELLAGER		BEARING
9	38	1	1	664610800		SPRENGRING		SNAP RING
9	39	1	1	664609200		SICHERUNGSRING		RETAINING RING
9	40	1	1	664004618		BOWDENZUG		CONTROL CABLE
9	41	1	1	664774215		ANBINDUNGSBLECH		BRACKET
9	42	1	1	664792611		SCHRAUBE		SCREW
9	43	1	1	664293201		MUTTER		NUT
9	51	2	2	664139100		KEIL		KEY
9	52	2	2	664463200		MESSERHALTER		BLADE HUB
9	53	1	1	664004345		FANGMESSER RECHTS		BLADE (COLLECT) RIGHT
9	54	1	1	664004344		FANGMESSER LINKS		BLADE (COLLECT) LEFT

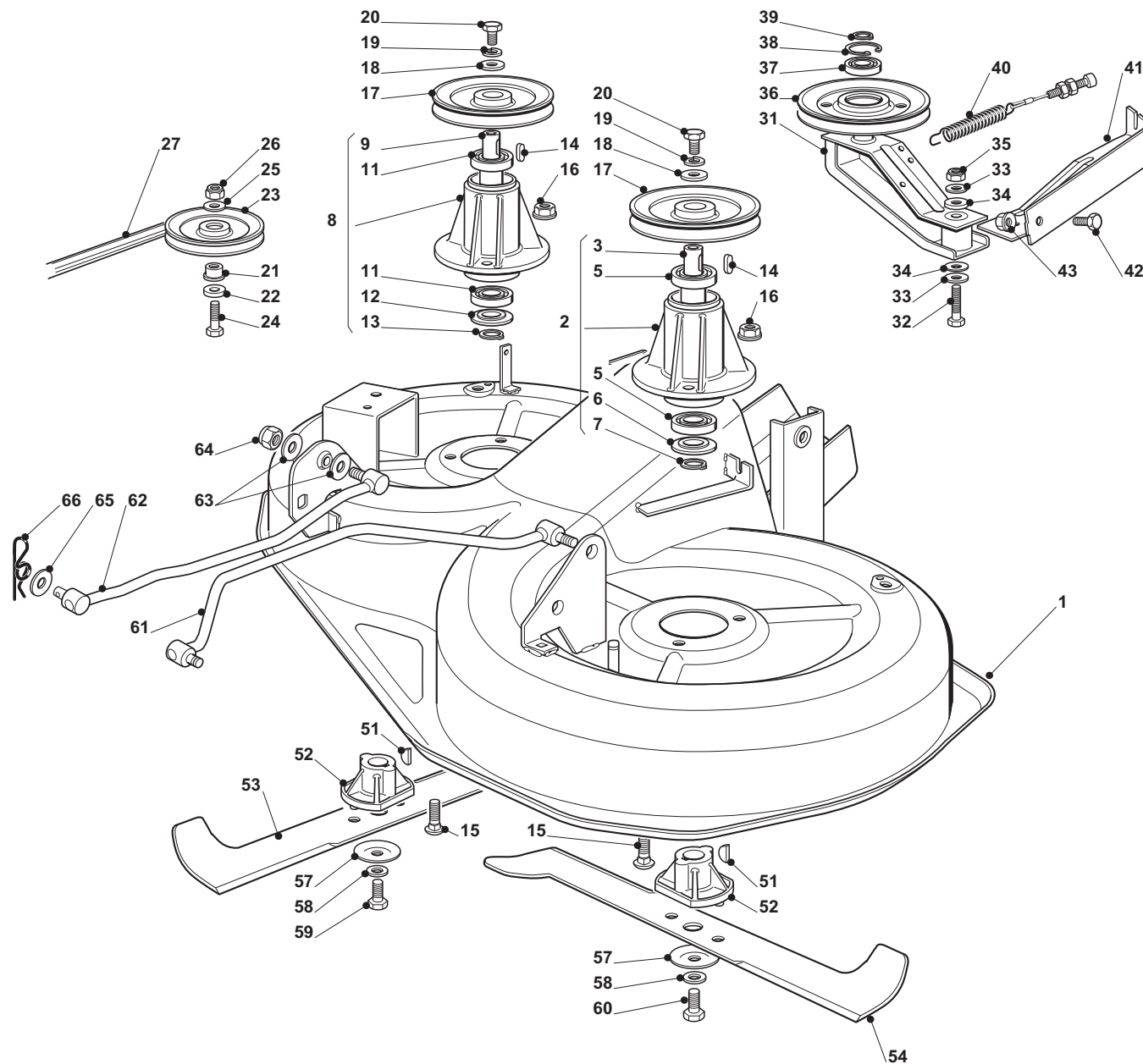

TM-92.14 (2015), TM-92.14 H
(2015)

9

SCHNEIDWERKZEUG (2)
CUTTING PLATE (2)



Seite / Page	Pos.	TM-92.14 (2015)	TM-92.14 H (2015)	Teil-Nr. Part No.	Hinweise Notes	Bezeichnung	Spezifikation Specification	Description
9	57	2	2	664160400		FEDERSCHEIBE		ELASTIC WASHER
9	58	2	2	664523080		SCHEIBE		WASHER
9	59	1	1	664735695		SCHRAUBE		SCREW
9	60	1	1	664735694		SCHRAUBE		SCREW
9	61	1	1	664000535		KIPPEBEL		EQUALIZER
9	62	1	1	664000533		KIPPEBEL		EQUALIZER
9	63	4	4	664670008		SCHEIBE		WASHER
9	64	2	2	664156602		MUTTER		NUT
9	65	2	2	664670008		SCHEIBE		WASHER
9	66	2	2	664487998		SPLINT		COTTER PIN

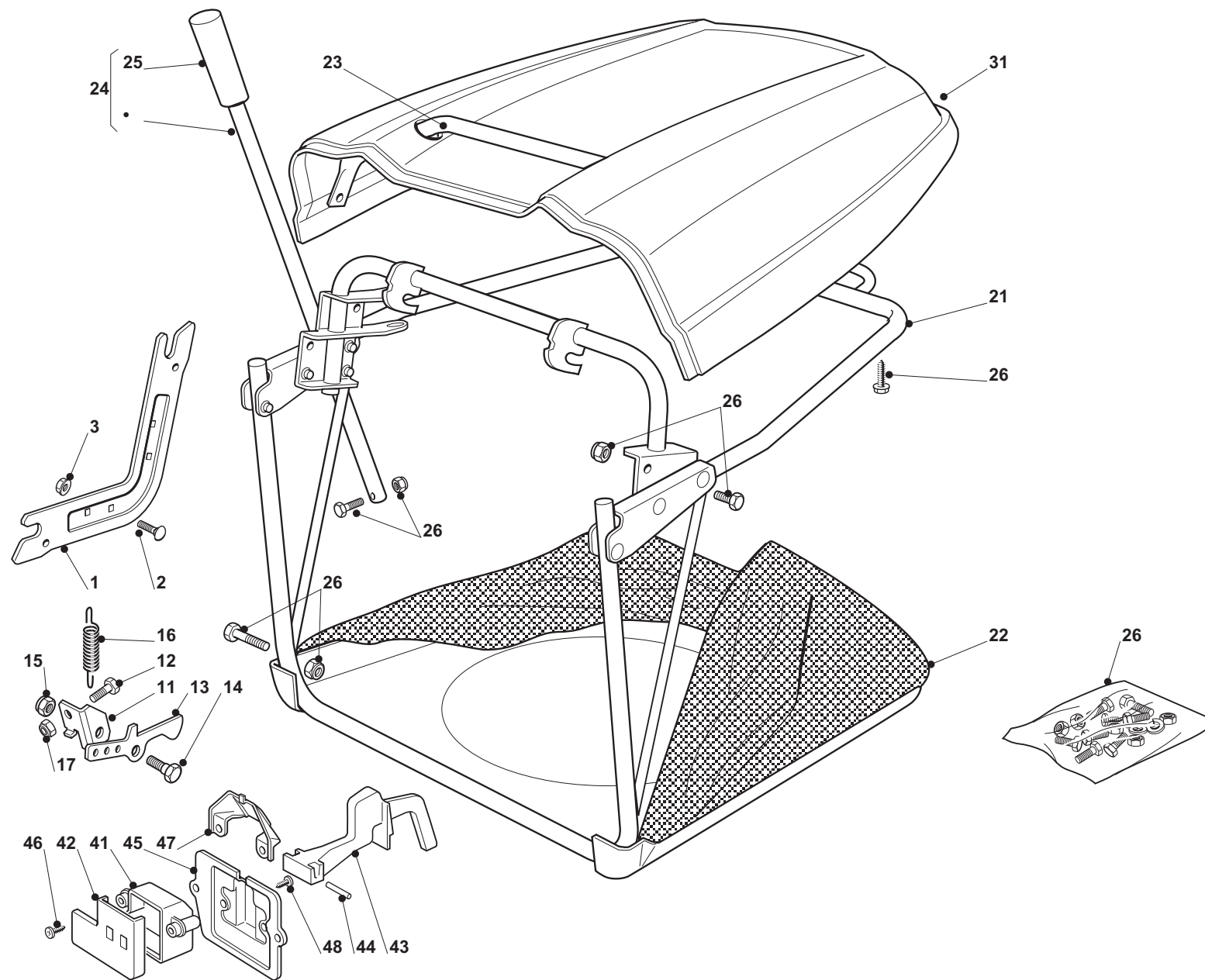



Seite / Page	Pos.	TM-92.14 (2015)	TM-92.14 H (2015)	Teil-Nr. Part No.	Hinweise Notes	Bezeichnung	Spezifikation Specification	Description
10	1	2	2	664785275		HALTER		SUPPORT
10	2	4	4	664818690		SCHRAUBE		SCREW
10	3	4	4	664293201		MUTTER		NUT
10	11	1	1	664028524		WINKEL		BRACKET
10	12	1	1	664789000		SCHRAUBE		SCREW
10	13	1	1	664774315		HALTER		BRACKET
10	14	1	1	664510080		BOLZEN		PIN
10	15	1	1	664292102		MUTTER		NUT
10	16	1	1	664450432		FEDER		SPRING
10	17	1	1	664154330		MUTTER		NUT
10	21	1	1	664800111		VORDERRAHMEN		FRONT FRAME
10	22	1	1	664105973		GRASS-SACK		GRASS CATCHER
10	23	1	1	664998003		VORDERGRIFF		HANDLE
10	24	1	1	664869023		STANGE	INC. 25	ROD
10	25	1	1	664999508		GRIFF		HANDLE
10	26	1	1	664180048		SCHRAUBENAUSRÜSTUNG		SCREWS OUTFIT
10	31	1	1	664110328		HAUBE, ROT		COVER, RED
10	41	1	1	664600041		SCHUTZ		PROTECTION
10	42	1	1	664600042		SCHUTZDECKEL		PROTECTION COVER
10	43	1	1	664318124		HEBEL		LEVER
10	44	1	1	664400030		BOLZEN		PIN
10	45	1	1	664785272		SCHUTZ		PROTECTION
10	46	1	1	664728510		SCHRAUBE		SCREW
10	47	1	1	664600048		ABWEISERDECKEL		DEFLECTOR COVER
10	48	2	2	664735110		SCHRAUBE		SCREW

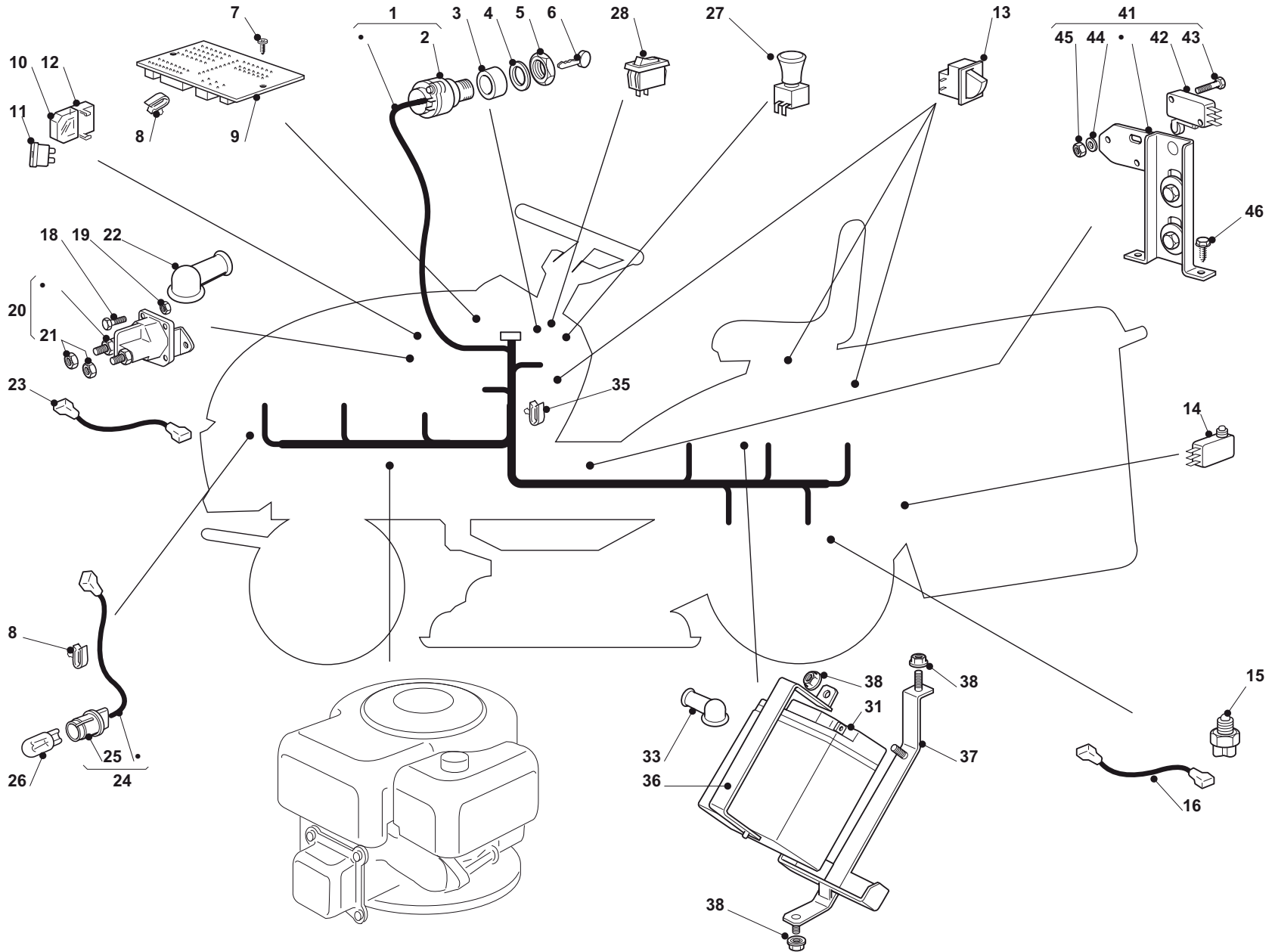



Seite / Page	Pos.	TM-92.14 (2015)	TM-92.14 H (2015)	Teil-Nr. Part No.	Hinweise Notes	Bezeichnung	Spezifikation Specification	Description
11	1	1	1	664028525		KABELSATZ	INC. 2	CABLES
11	2	1	1	664450072		SCHALTER		STARTING SWITCH
11	3	1	1	664550136		DISTANZRING		SPACER
11	4	1	1	664550135		SCHEIBE		WASHER
11	5	1	1	664400862		NUTMUTTER		RING NUT
11	6	1	1	664210022		SCHLÜSSEL FÜR START		STARTING KEY
11	7	3	3	664727810		SCHRAUBE		SCREW
11	8	2	2	664320506		KABELBEFESTIGUNG		FAIRLEAD
11	9	1	1	664028526		ELEKTRONISCHE KARTE		ELECTRONIC CARD
11	10	2	2	664215000		DECKEL		COVER
11	11	1	1	664340036		SICHERUNG	25A	FUSE
11	11	1	1	664340040		SICHERUNG	10A	FUSE
11	12	2	2	664500007		SICHERUNGHALTER		FUSE CARRIER
11	13	3	3	664410613		MIKROSCHALTER		MICRO SWITCH
11	14	1	1	664410605		FÜLLHÖHENSCHALTER		FULL GRASS CATCHER MICRO
11	15	1		664410608		MIKROSCHALTER LEERLAUF		SWITCH
11	16	1		664065026		KABEL		CABLE
11	18	2	2	664791213		SCHRAUBE		SCREW
11	19	2	2	664292102		MUTTER		NUT
11	20	1	1	664736110		ANLASSRELAIS	INC. 21	STARTER RELAY
11	21	2	2	664945131		MUTTER		NUT
11	22	1	1	664564864		STECKER		CONNECTOR
11	23	1	1	664065017		KABEL		CABLE
11	24	1	1	664040073		KABEL	DELI TIRE INC. 25	CABLE
11	25	2	2	664999030		LAMPENFASSUNG		LAMP SOCKET
11	26	2	2	664459100		LAMPE HALOGEN		LAMP, HALOGEN
11	27	1	1	664450068		KUPPLUNGSSCHALTER		CLUTCH SWITCH
11	28	1	1	664450060		LICHTSCHALTER		SWITCH
11	31	1	1	664120002		BATTERIE		BATTERY
11	33	1	1	664564861		STECKER		PROTECTION
11	35	9	9	664320506		KABELBEFESTIGUNG		FAIRLEAD
11	36		1	664772099		BATTERIEHALTER		CLAMP
11	37		1	664785191		BATTERIEHALTER		BATTERY SUPPORT
11	38		3	664155000		MUTTER		NUT
11	41		1	664394853		MIKROSCHALTER SATZ	HYDRO INC. 42-45	MICRO SWITCH SET
11	42		1	664410609		MIKROSCHALTER LEERLAUF		SWITCH
11	43		2	664735602		SCHRAUBE		SCREW
11	44		2	664581100		FEDERRING		SPRING RING
11	45		2	664290791		MUTTER		NUT
11	46		2	664735110		SCHRAUBE		SCREW

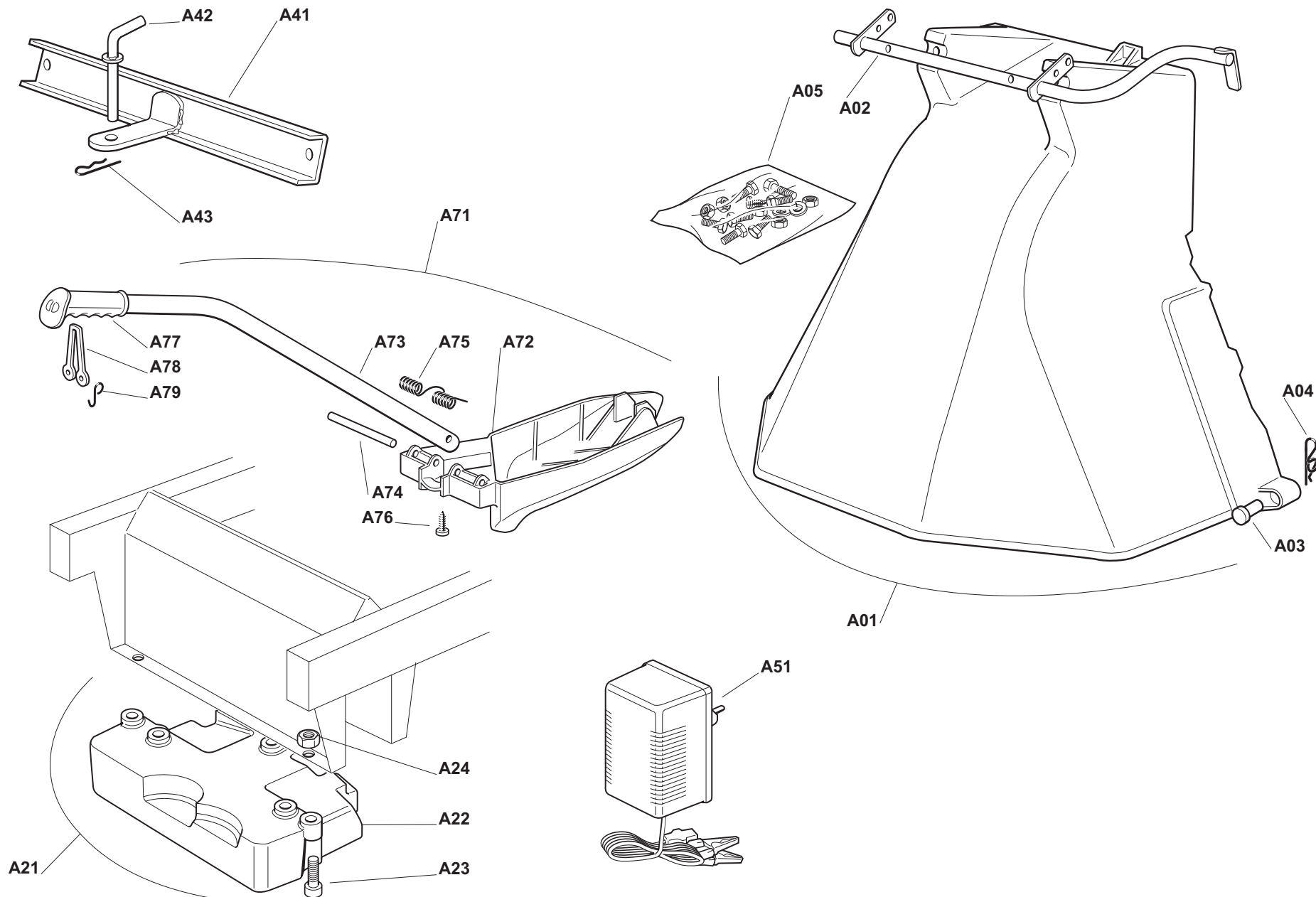



Seite / Page	Pos.	TM-92.14 (2015)	TM-92.14 H (2015)	Teil-Nr. Part No.	Hinweise Notes	Bezeichnung	Spezifikation Specification	Description
12	A01	1	1	664900051		DEFLEKTORHAUBE	INC. A02-A05	KIT PROTECTION SORTIE
12	A02	1	1	664999035		HALTER		SUPPORT
12	A03	2	2	664510022		BOLZEN		PIN
12	A04	2	2	664487998		SPLINT		COTTER PIN
12	A05	1	1	664180062		SCHRAUBENAUSRÜSTUNG		SCREWS OUTFIT
12	A21	1	1	664900030		FRONTGEWICHT KPL.	72-92-102-122 INC. A22-A24	FRONT WEIGHT KIT
12	A22	1	1	664519997		FRONTGEWICHT	72-92-102-122	FRONT WEIGHT
12	A23	3	3	664760520		SCHRAUBE		SCREW
12	A24	3	3	664155000		MUTTER		NUT
12	A41	1	1	664900084		ANHÄNGERKUPPLUNG		TRAILER HITCH KIT
12	A42	1	1	664510021		BOLZEN		PIN
12	A43	1	1	664487999		SPLINT		COTTER PIN
12	A51	1	1	664180050		LADEGERÄT	EU (SCHUKO)	BATTERY CHARGER
12	A51	1	1	664180091		LADEGERÄT	U.K.	BATTERY CHARGER
12	A71	1	1	664900038		MULCHKEIL	INC. A72-A76	KIT MULCHING
12	A71	1	1	664900138	ACC.	MULCHKEIL&MULCHMESSER	92 cm INC. A72-A76	KIT MULCHING (INCL. LAME)
12	A72	1	1	664140093		ABWEISER		DEFLECTOR
12	A73	1	1	664394007		STIEL		HANDLE
12	A74	1	1	664510077		BOLZEN		PIN
12	A75	1	1	664430245		FEDER		SPRING
12	A76	1	1	664735410		SCHRAUBE		SCREW
12	A77	1	1	664280000		GRIFF		HANDGRIP
12	A78	1	1	664840011		GUMMIZUG		ELASTIC TIE-ROD
12	A79	2	2	664253004		HAKEN		HOOK

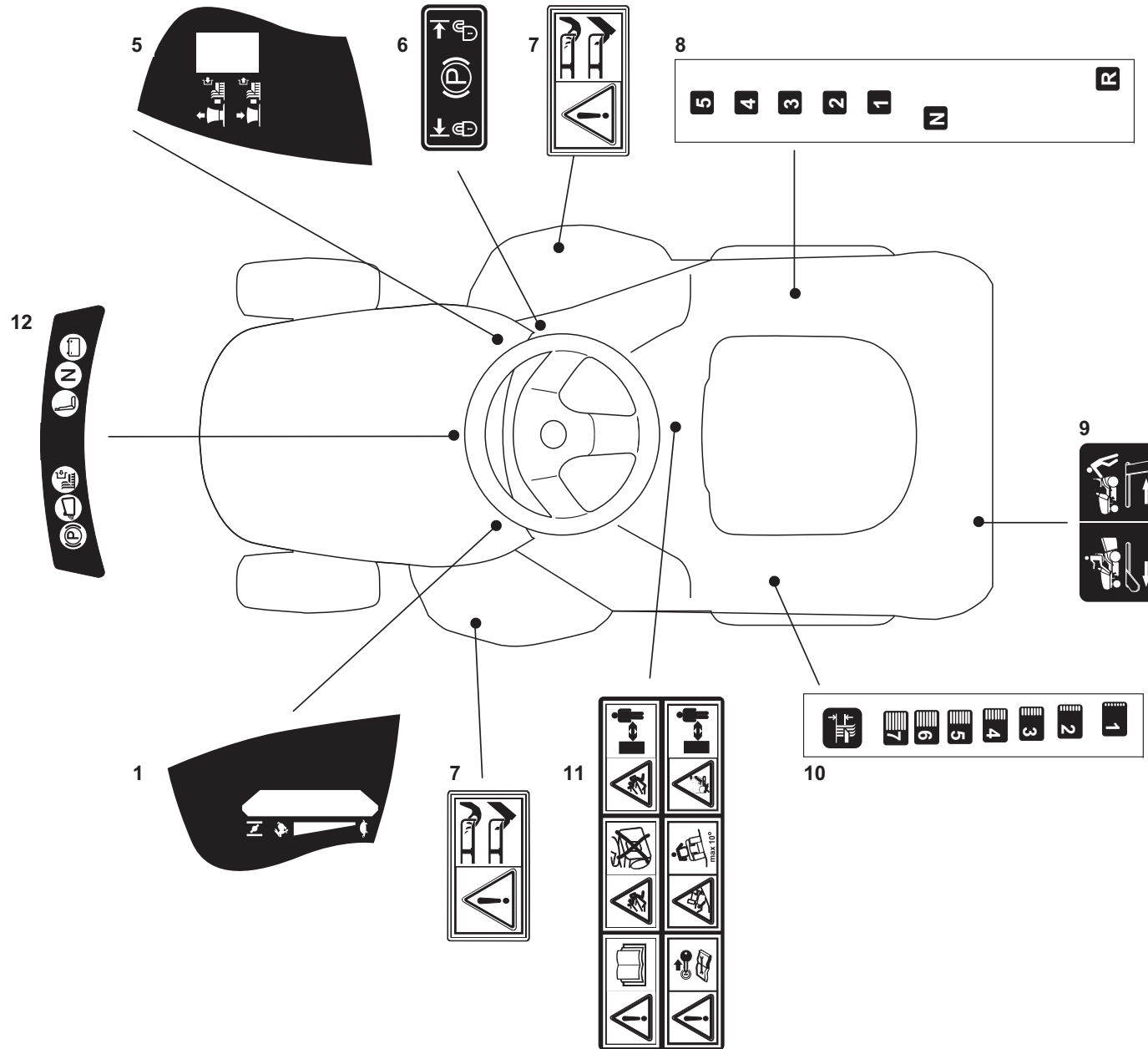



Seite / Page	Pos.	TM-92.14 (2015)	TM-92.14 H (2015)	Teil-Nr. Part No.	Hinweise Notes	Bezeichnung	Spezifikation Specification	Description
13	1	1	1	664361440		SCHILD, MOTORFERNBEDIENUNG		LABEL, THROTTLE
13	5	1	1	664361439		SCHILD, MESSERKUPPLUNG		LABEL, KNIFE COUPLING
13	6	1	1	664361452		SCHILD, PARKBREMSE		LABEL, PARKING BRAKE
13	7	2	2	664356699		SCHILD SICHERHEITSHINWEISE		LABEL, SAFETY INSTRUCTIONS
13	8	1		664361447		SCHILD, GANGSCHALTUNG		LABEL, SPEED DRIVE CONTROL
13	9		1	664361451		SCHILD BEDIENHINWEISE		LABEL, CAUTION
13	10	1	1	664361441		SCHILD, SCHNITTHÖHENVERSTELLUNG		LABEL, HEIGHT ADJUSTMENT
13	11	1	1	664361553		SCHILD SICHERHEITSHINWEISE		LABEL, SAFETY INSTRUCTIONS
13	12	1	1	664420020		SCHILD BEDIENHINWEISE		LABEL

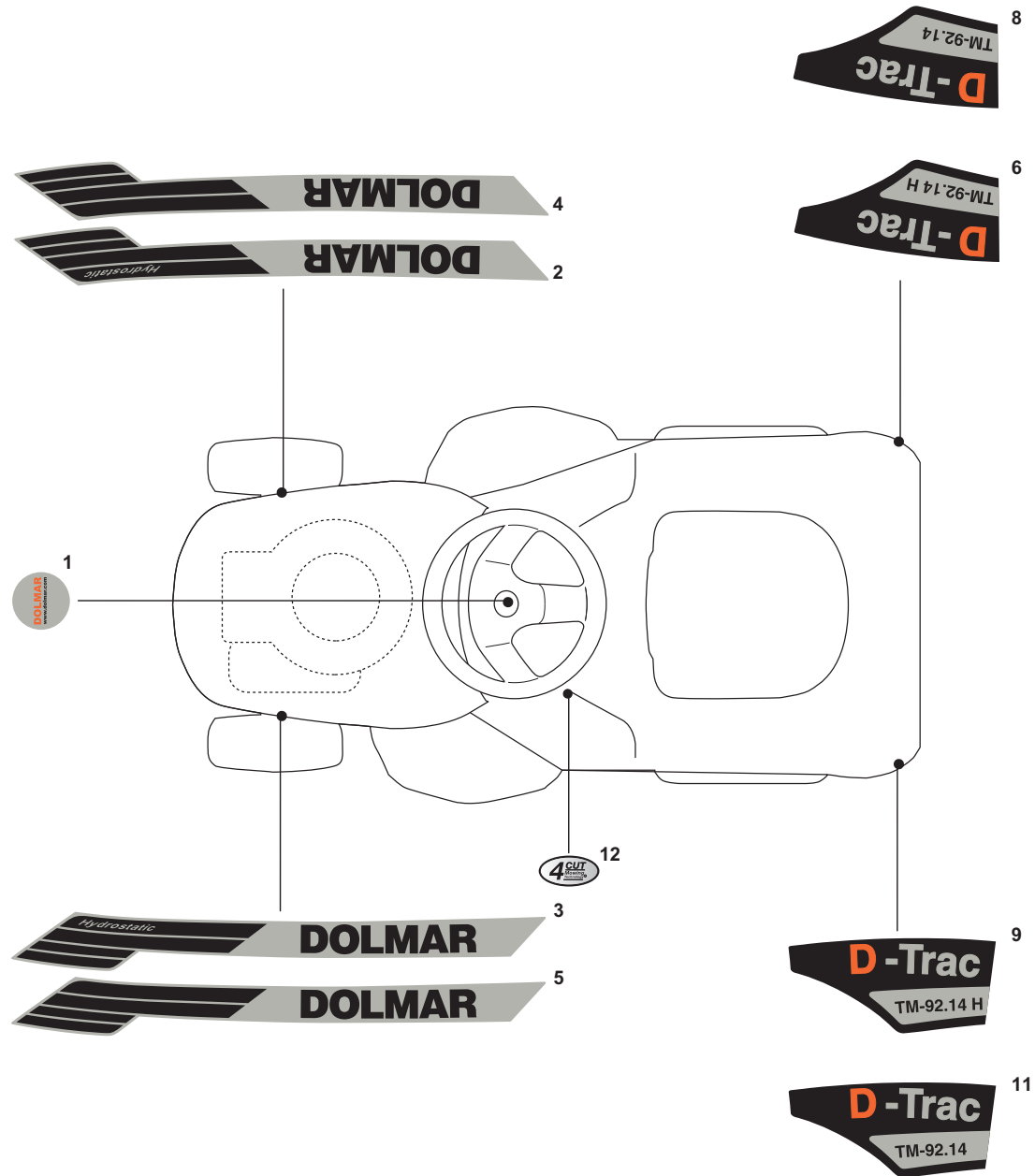



Seite / Page	Pos.	TM-92.14 (2015)	TM-92.14 H (2015)	Teil-Nr. Part No.	Hinweise Notes	Bezeichnung	Spezifikation Specification	Description
14	1	1	1	664361485		SCHILD	DOLMAR	LABEL
14	2			664362510		SCHILD	DOLMAR	LABEL
14	3			664362511		SCHILD	DOLMAR	LABEL
14	4	1		664362508		SCHILD	DOLMAR	LABEL
14	5	1		664362509		SCHILD	DOLMAR	LABEL
14	6		1	664362514		SCHILD	TM-92.14 H	LABEL
14	8	1		664362516		SCHILD	TM-92.14	LABEL
14	9		1	664362515		SCHILD	TM-92.14 H	LABEL
14	11	1		664362517		SCHILD	TM-92.14	LABEL
14	12	1	1	664999576		SCHILD	4 CUT	LABEL

TM-92.14 (2015), TM-92.14 H
(2015)



	Zeichenerklärung	Key to symbols
=> 1999999 2000000 => 2003.04 => TI 2003/07 Acc. = { m Corr.	Produktion bis Serien-Nr. Neues Teil ab Serien-Nr. Neues Teil ab Jahr / Monat Siehe Technische Information Jahr / Nr. Zubehör (nicht im Lieferumfang) Keine Serienausführung, jedoch verwendbar Beinhaltet Positions-Nr. Meterware Druckfehlerberichtigung	Production to serial number New part from serial number New part from Year / Month See Technical Information Year / No. Accessories (not included in the delivery inventory) No standard execution, may be used Contains item number Sold by the meter Error correction
	Änderungen vorbehalten	Specifications subject to change without notice