

Model No.SK209GD GREEN MULTI LINE LASER

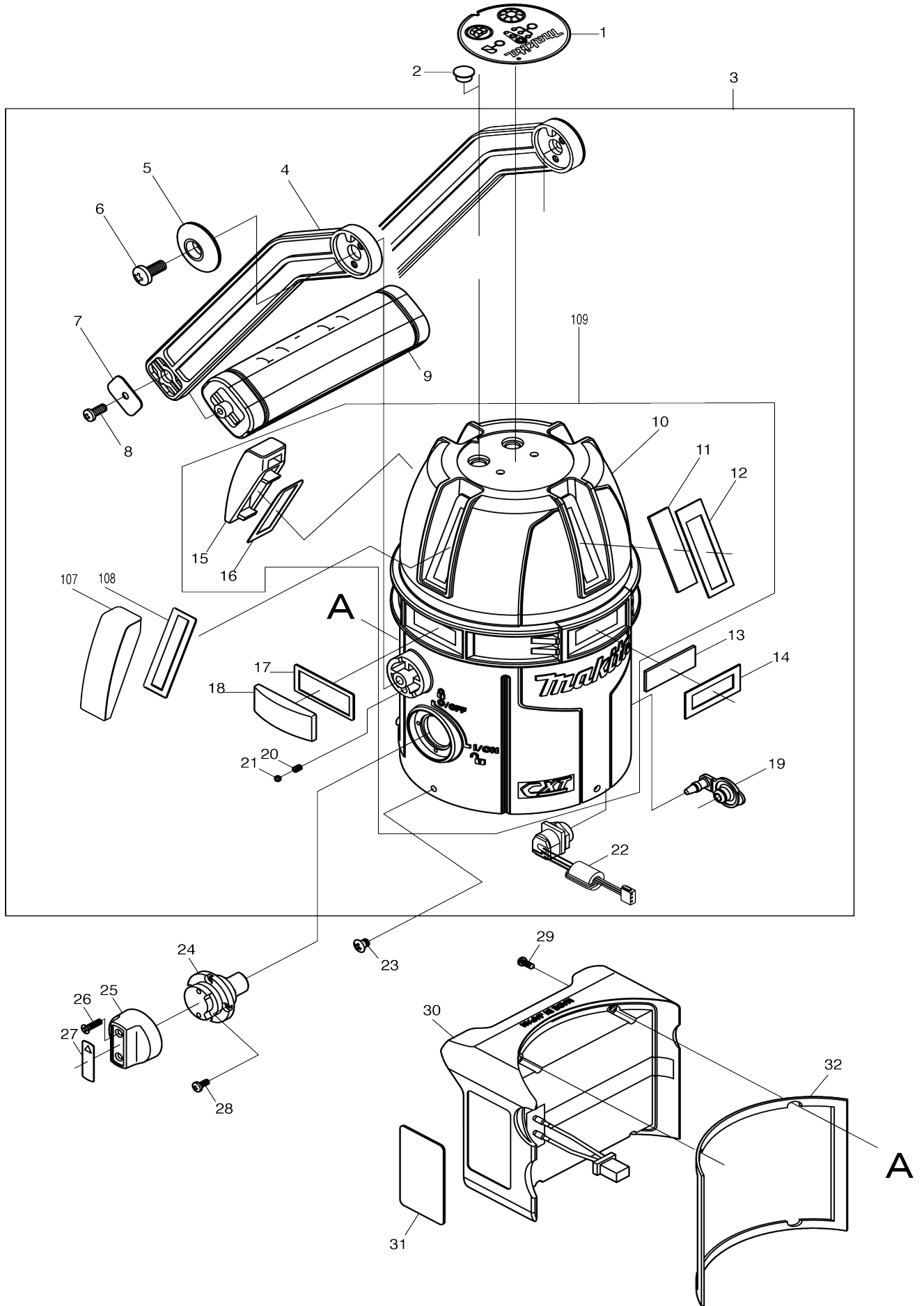

Model No. SK209GD GREEN MULTI LINE LASER

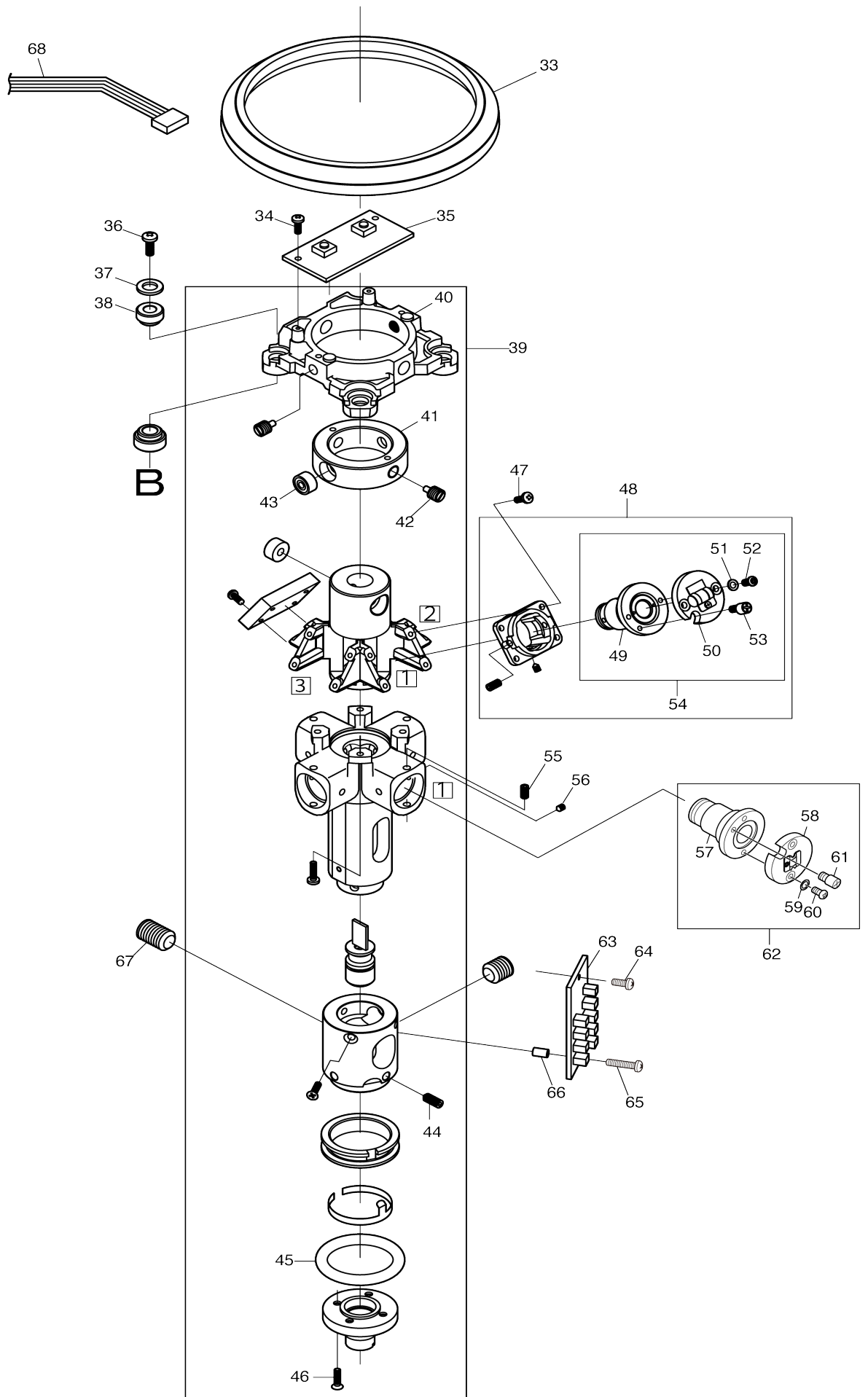

Model No.SK209GD GREEN MULTI LINE LASER

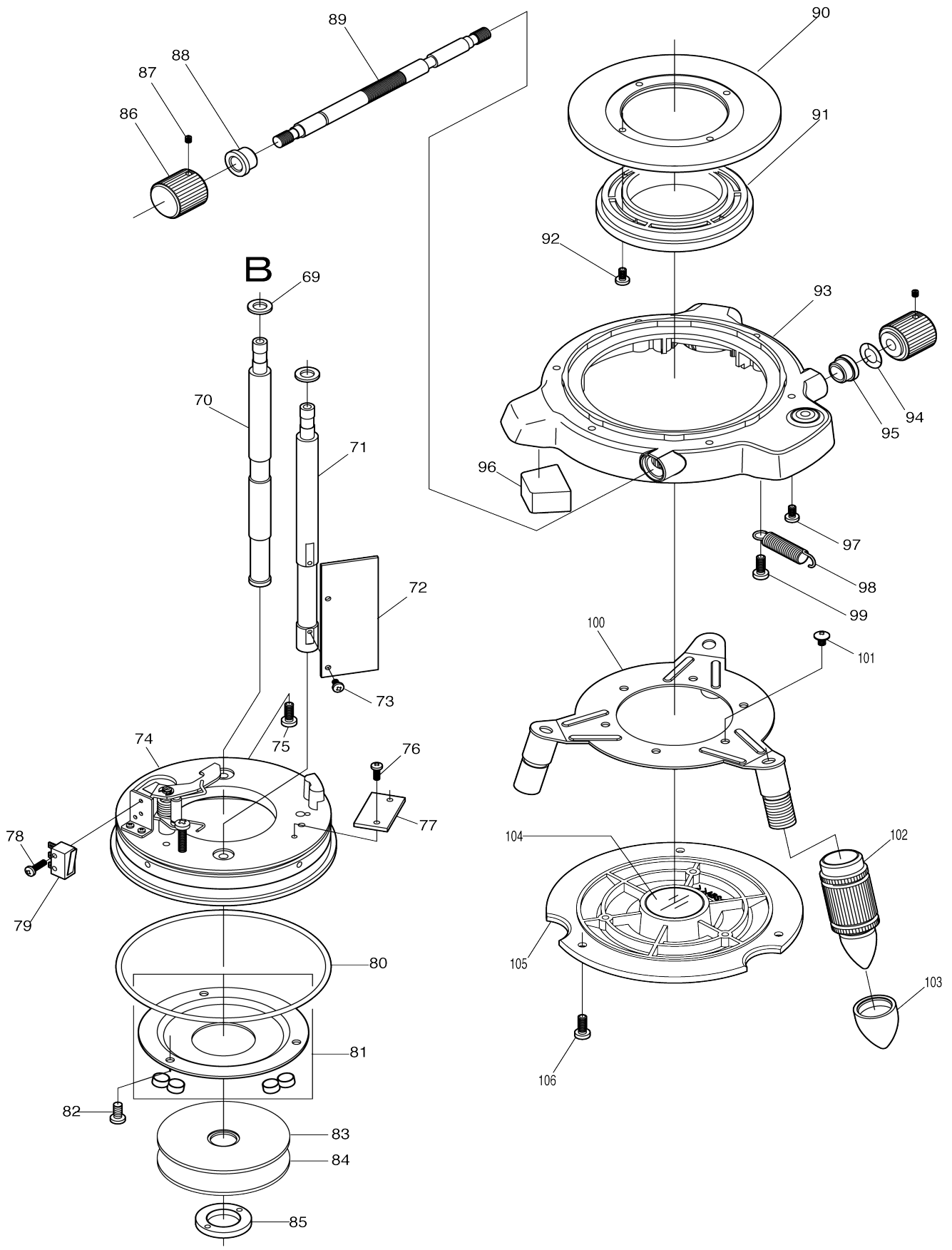

Model No.SK209GD GREEN MULTI LINE LASER

Item No.	Parts No.	Description	Interchangeability	Q'ty	New/Old	Note1	Note2
001	TK219UN101	SWITCH LABEL		1			
002	TK16010422	SWITCH BUTTON(2.2)		2	*		
002-1	TK16010441	SWITCH BUTTON(4.1)	X	2			
002A_	TK16010423	SWITCH BUTTON(2.3)		2	*		
002A1	TK16010443	SWITCH BUTTON(4.3)	X	2			
002B_	TK16010424	SWITCH BUTTON(2.4)		2	*		
002B1	TK16010444	SWITCH BUTTON(4.4)	X	2			
003	TK220EUSA1	HOUSING ASSEMBLY		1	*		
D10		INC. 4-9,13,14,17-22,107-109					
003-1	TK2191EU01	HOUSING COMPLETE	<	1			
D10		INC. 4-9,13,14,17-22,109					
004	TK02181041	HANDLE		2			
005	TK02181261	HANDLE RETAINER		2			
006	TKTP4010FU	+PAN HEAD SCREW M4X10		2	*		
006-1	TKP4010FUS	+PANHEADSCREWM4X10(WITH RUBBER)	X	2			
007	TK02180127	GRIP RETAINER		2			
008	TKTT3010FB	+TRUSS HD. TAPPING SCREW 3X10		2			
009	TK02181051	GRIP		1			
010	TK219102EU	HOUSING COMPLETE		1	*		
011	TK00210106	GLASS V		2			
012	TK02180128	GLASS V RETAINER LABEL		2			
013	TK02101071	GLASS H		1			
014	TK02180129	GLASS H RETAINER LABEL		1			
015	TK02190125	COVER V		1			
016	TK02190128	DOUBLE SIDES LABEL V		1			
017	TK02190126	COVER H		3	*		
017-1	TK02190129	DOUBLE SIDES LABEL H	X	3			
018	TK02190129	DOUBLE SIDES LABEL H		3	*		
018-1	TK02190126	COVER H	X	3			
019	TKAL411252	DC JUCK COVER		1			
020	TK02181302	COMPRESSION SPRING E		2			
021	TK00SB3000	STELL BALL 3		2			
022	TK219UN131	DC JUCK UN		1			
023	TK0P2550FB	+ PAN HEAD SCREW M2.5X5		4			
024	TK0195SA01	LOCK CAM COMPLETE		1	*		
024-1	TK195SA011	LOCK CAM COMPLETE	O	1			
025	TK01701192	LOCK LEVER		1			
026	TK03F2080N	COUTERSUNK HD. SCREW M2X8		2			
027	TK01700104	SWITCH KNOB LABEL		1	*		
027-1	TK01700104	SWITCH KNOB LABEL	O	1			
028	TKTP2040FU	+PAN HEAD SCREW 2X4		4			
029	TKTP2080FB	TAPPING SCREW 2X8		4	*		
029-1	TKTP2080FB	TAPPING SCREW 2X8	O	4			
030	TK02180008	BATTERY HOLDER COMPLETE		1			
031	TK220EU113	NAME PLATE 220 EU		1			
032	TK02181242	BATTERY HOLDER GASKET		1			

033	TK02180103	HOUSING RETAINER RING		1	*		
033-1	TK02181031	HOUSING RETAINER RING	O	1			
034	TK03P2040N	PAN HD.SCREW M2X4		2			
035	TKLVF0076D	SWITCH UNIT		1			
036	TK0T3060FU	+TRUSS HD. SCREW 3X6		3			
037	TK0000PW50	FLAT WASHER 5		3			
038	TK01731383	PILLAR BUSH		6			
039	TK0220SA02	GIMBAL ASSEMBLY		1	*		
D10		INC. 40-46					
039-1	TK220SA021	GIMBAL ASSEMBLY	S	1			
D10		INC. 40-46					
040	TK01830135	UPPER FRAME		1			
041	TK00174111	GIMBAL INNER RING		1			
042	TK01730196	FULCRUM SCREW		4			
043	TK01730199	BALL BEARING		4			
044	TKS3060FB5	HEX SOCKET HD. SCREW M3X6		4			
045	TK01730148	O RING		1			
046	TK0F2580B0	FLAT HEAD SCREW M2.5X8		4			
047	TK03P2040N	PAN HD.SCREW M2X4		16			
048	TK219SA03E	LASER UNIT V COMPLETE		2			
D10		INC. 54					
049	TK02160111	LASER UNIT G COMPLETE		1			
050	TK00218012	LENS		1			
051	TK0000PW20	FLAT WASHER		2			
052	TK03P2060N	PAN HD.SCREW M2X6		2			
053	TK0LV37351	ECCENTRIC SCREW		1			
054	TK219SA04E	LASER UNIT COMPLETE		1			
D10		INC. 49-53					
055	TKS2550S05	H.S.SET SCREW(FLAT POINT)		2			
056	TKS2540FB4	H.S.SET SCREW M2.5X4		2			
057	TK02160111	LASER UNIT G COMPLETE		1			
058	TK00218012	LENS		1			
059	TK0000PW20	FLAT WASHER		2			
060	TK03P2060N	PAN HD.SCREW M2X6		2			
061	TK0LV37351	ECCENTRIC SCREW		1			
062	TK219SA04E	LASER UNIT COMPLETE		1			
D10		INC. 57-61					
063	TKLVF0068B	CONTROL UNIT		1	*		
063-1	TKLVF0068F	CONTROL UNIT G3L-LF	O	1			
064	TK03P2040N	PAN HD.SCREW M2X4		1			
065	TK03P2080N	PAN HD. SCREW M2X8		1			
066	TKST2060FZ	SPACER		1			
067	TK0219SET1	BALANCER WEIGHT SET		1	*		
068	TK0LVE3044	LEAD UNIT A		1			
069	TK0000PW50	FLAT WASHER 5		3			
070	TK01701146	PILLAR A		2			
071	TK02100118	PILLAR B		1			
072	TKLVF00753	POWER SUPPLY UNIT		1			
073	TK03P2040N	PAN HD.SCREW M2X4		2			
074	TK0218SA05	LOWER FRAME COMPLETE		1			
075	TK0P3080FU	+PAN HD. SCREW M3X8		3			
076	TK03P2040N	PAN HD.SCREW M2X4		2			

077	TK0LVF0066	CONNECTOR UNIT		1		
078	TK03P2080N	PAN HD. SCREW M2X8		2		
079	TK0TL32108	SWITCH		1		
080	TK01501151	O RING		1		
081	TK0173SA13	MAGNET UNIT		1	*	
081-1	TK173SA131	MAGNET UNIT	S	1		
082	TK0P3060FU	+PAN HEAD SCREW M3X6		3		
083	TK00170132	DAMPER PLATE A		1	*	
084	TK01730156	DAMPER PLATE B		1	*	
084-1	TK01730156	DAMPER PLATE B	S	2		
085	TKLV272921	RING NUT		1		
086	TK01970106	ADJUSTING WHEEL		2		
087	TKS2540FB4	H.S.SET SCREW M2.5X4		2		
088	TK01821171	BUSH		1		
089	TK01821141	ADJUSTING ROD		1		
090	TK01821161	ROTATION RING		1		
091	TK01821152	ADJUSTING RING		1		
092	TK0P2550FU	+PAN HD. SCREW M2.5X5		4		
093	TK0218118S	ADJUSTING FLAME		1		
094	TK00WW50S0	WAVE WASHER 5		1		
095	TK01850105	BUSH		1		
096	TK01851071	SPONGE		3		
097	TK0P2560FU	+PAN HD. SCREW M2.5X6		3		
098	TK01821181	TENSION SPRING		1		
099	TKTP2550FB	+PAN HD. SCREW M2.5X5		1		
100	TK0218121S	TRIPOD		1		
101	TKTT3070FU	+TRUSS HD. TAPPING SCREW 3X 7		3		
102	TK02180108	SPIKE		3		
103	TK01581222	SPIKE CAP		3		
104	TK0LV36971	COVER GLASS		1	*	
104-1	TK02180136	COVER SHEET	O	1		
105	TK01821112	UNDER COVER ASSEMBLY		1		
106	TKTP3010FB	+TAPPING SCREW 3X10		3		
107	TK02190125	COVER V		1		
108	TK02190128	DOUBLE SIDES LABEL V		1		
109	TK2191EU01	HOUSING COMPLETE		1	*	
D10		INC. 10-12,15,16				
109-1	TK219102EA	HOUSING COMPLETE	<	1		
D10		INC. 11-18				
A01	TK0219UNIM	CD-ROM		1		
A02	TK219UNQSG	OPERATION GUIDE		1		
A03	TK0219UNSB	SAFETY MANUAL		1		
A04	TK02100200	GLASSES LASER VISIBILITY		1		
A05	TK00SB0001	SHOULDER BELT		1		
A06	TKAK400MUS	STORAGE CASE		1	*	
A06-1	TKAK400M00	STORAGE CASE	>	1		
A07	TK220UNCB1	CARTON		1		
A08	TK00220901	MODEL LABEL		1		

Please state Parts No. when your order.

Print Date 23/10/2023