

Model No. UC4050A ELECTRIC CHAIN SAW 400MM

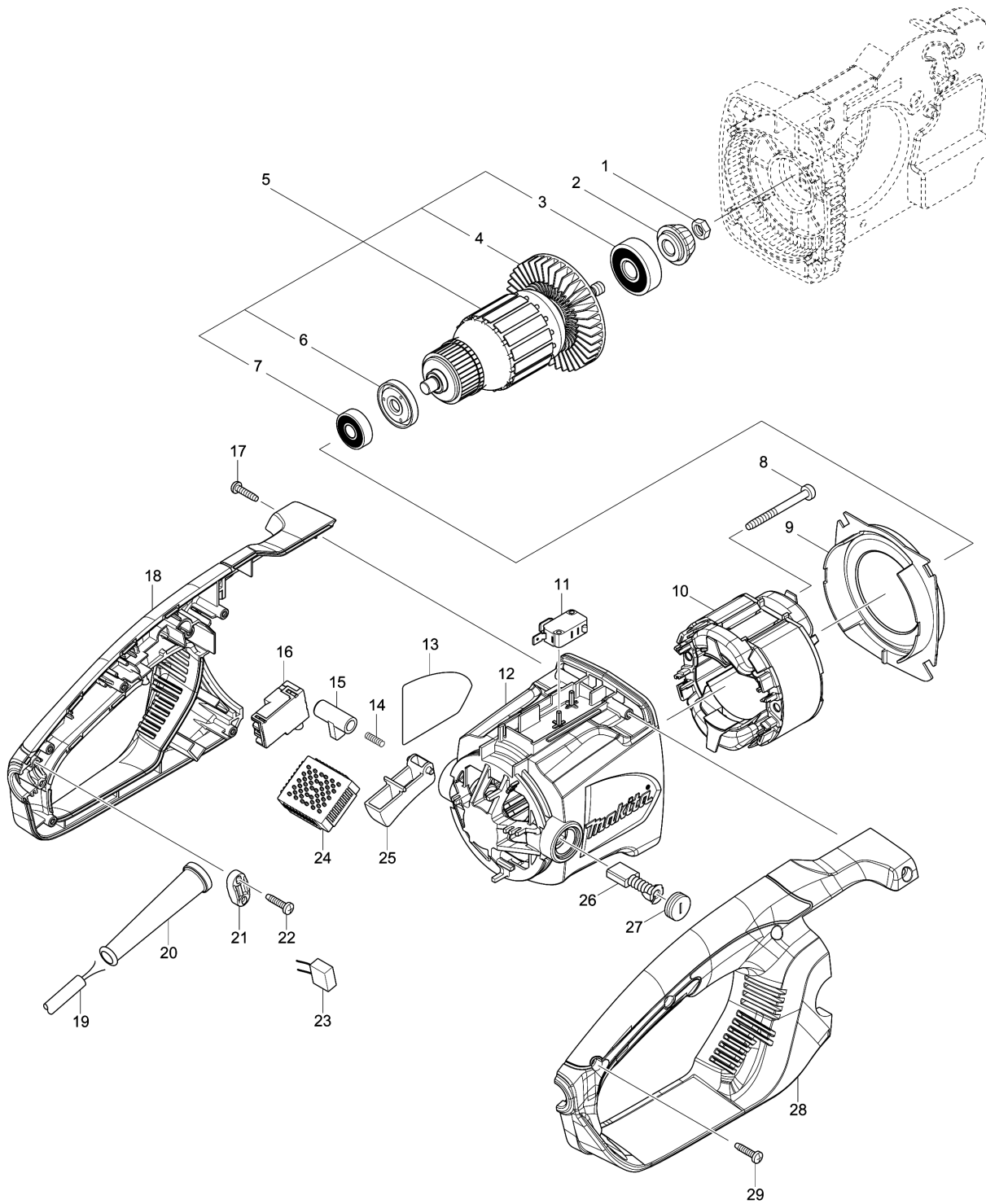

Model No.UC4050A ELECTRIC CHAIN SAW 400MM

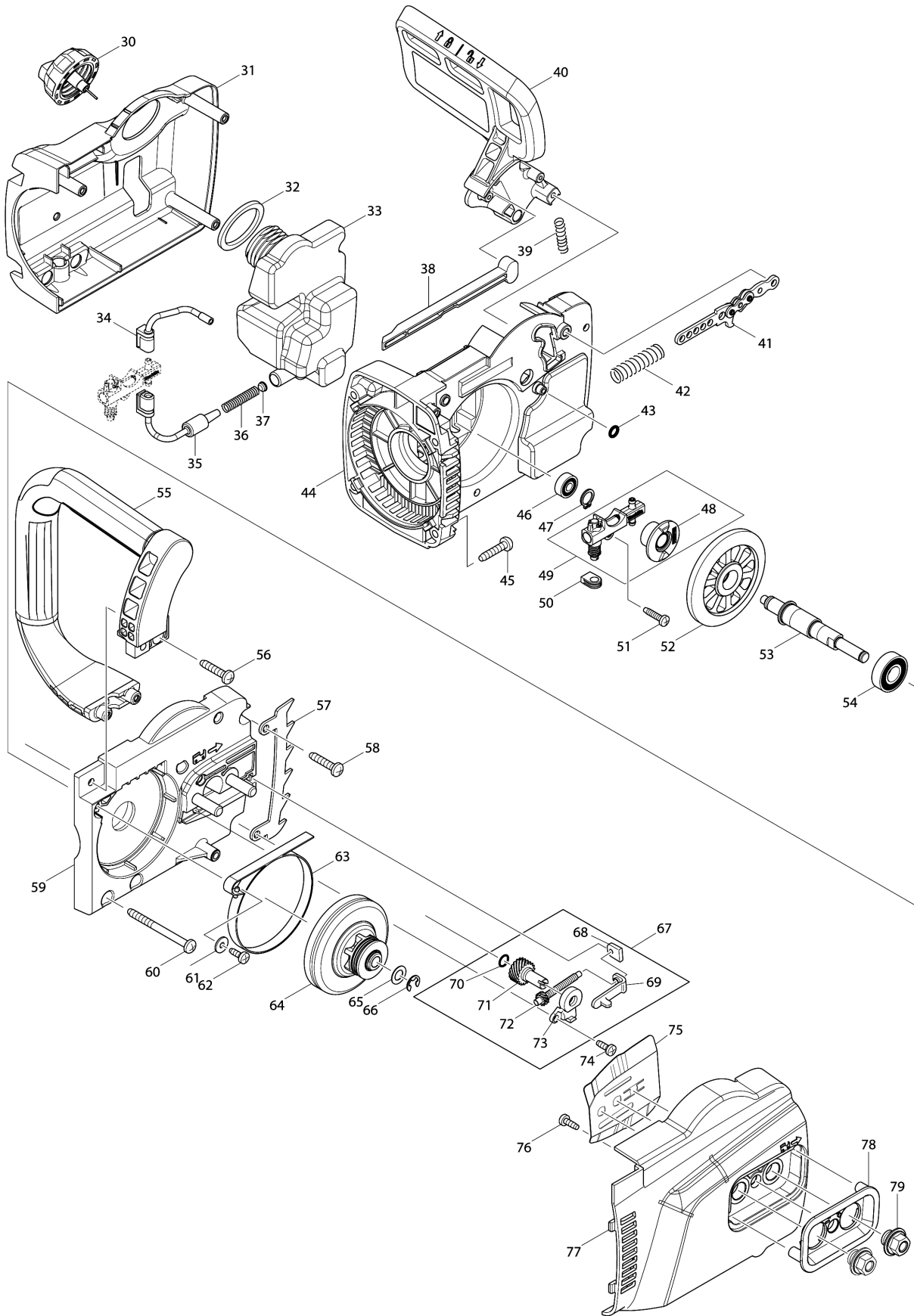

Model No.UC4050A ELECTRIC CHAIN SAW 400MM

Item	Parts No.	Description	I/C	Qty	New/Old	Opt. 1	Opt. 2	Note
001	931403-6	HEX. NUT M8		1				
002	227626-5	SPIRAL BEVEL GEAR 12		1				
003	211111-8	BALL BEARING 6301LLB		1				
004	240003-4	FAN 80		1				
005	517904-4	ARMATURE ASS'Y 240V		1				
D10		INC. 3,4,6,7						
006	681666-1	INSULATION WASHER		1				
007	210084-2	BALL BEARING 629ZZ		1				
008	266095-5	TAPPING SCREW 5X55		2				
009	419410-4	BAFFLE PLATE		1				
010	636394-3	FIELD 240V		1	*			
010-1	520156-8	FIELD ASS'Y 240V	<	1				
C10	654020-2	RING TERMINAL		2				
C20	654501-6	CONNECTOR P-1.25		2				
C30	654207-6	RECEPTACLE		1				
011	650577-1	SWITCH SD-006-BB2AA-AA		1				
012	142348-5	MOTOR HOUSING COMPLETE		1				
C10	643653-8	BRUSH HOLDER 6.5-13.5		2	*			
C11	643536-2	BRUSH HOLDER 6.5X13.5	<	2				
013	815F93-8	UC4050A NAME PLATE		1				
014	233173-6	COMPRESSION SPRING 4		1				
015	416178-3	LOCK-OFF BUTTON		1	*			
015-1	413B17-0	LOCK OFF BUTTON	<	1				
016	650717-1	SWITCH TGC30B		1				
017	265995-6	TAPPING SCREW 4X18		1				
018	187901-0	HANDLE SET		1				
C10	802G51-9	CAUTION LABEL		1				
D10		INC. 28						
019	665894-6	POWER SUPPLY CORD 1.0-2-0.5		1				
020	682540-6	CORD GUARD 9.3-90		1				
021	687124-5	STRAIN RELIEF		1				
022	265995-6	TAPPING SCREW 4X18		2				
023	645105-5	NOISE SUPPRESSOR		1				
024	631719-6	CONTROLLER		1	*			
024-1	620M13-9	CONTROLLER	<	1				
025	419411-2	SWITCH LEVER		1				
026	181044-0	CARBON BRUSH CB-153		1				
027	643650-4	BRUSH HOLDER CAP 6.5-13.5		2	*			
027-1	643650-4	BRUSH HOLDER CAP 6.5-13.5	O	2				
028	187901-0	HANDLE SET		1				
C10	802G51-9	CAUTION LABEL		1				
D10		INC. 18						
029	265995-6	TAPPING SCREW 4X18		6				
030	142282-9	TANK CAP COMPLETE		1				
031	454822-4	GEAR HOUSING COVER		1				

Please order the parts with part number.

Print Date 22/1/2024

Model No.UC4050A ELECTRIC CHAIN SAW 400MM

Item	Parts No.	Description	I/C	Qty	New/Old	Opt. 1	Opt. 2	Note
032	421959-2	SPONGE SEAL		1				
033	454826-6	OIL TANK		1				
034	424611-1	CONNECTOR B		1				
035	424610-3	CONNECTOR A		1				
036	231975-4	SPRING		1				
037	416274-7	CAP		1				
038	454825-8	ROD		1				
039	233174-4	COMPRESSION SPRING 6		1				
040	142341-9	FRONT HAND GUARD COMPLETE		1				
C10	802K54-7	INDICATION LABEL		1				
041	158044-5	LINK PLATE COMPLETE		1				
042	234005-0	COMPRESSION SPRING 9		1				
043	213017-6	O RING 6		1				
044	454821-6	GEAR HOUSING		1				
045	266041-8	TAPPING SCREW 5X25		4				
046	210028-2	BALL BEARING 606ZZ		1				
047	961006-2	RETAINING RING S-10		1				
048	221427-3	WORM GEAR		1				
049	196419-0	OIL PUMP SET		1	*			
D10		INC. 48			*			
049-1	142156-4	OIL PUMP COMPLETE	<	1	*			
049-2	142156-4	OIL PUMP COMPLETE	O	1				
050	424612-9	GROMMET		1				
051	265995-6	TAPPING SCREW 4X18		1				
052	227627-3	SPIRAL BEVEL GEAR 37		1				
053	326373-6	SPINDLE		1				
054	210107-6	BALL BEARING 6001ZZ		1				
055	454823-2	FRONT HANDLE		1				
056	266041-8	TAPPING SCREW 5X25		2				
057	345651-5	SPIKE BUMPER		1				
058	266041-8	TAPPING SCREW 5X25		2				
059	319092-1	BEARING HOUSING		1				
060	266044-2	TAPPING SCREW 5X60		2				
061	267195-4	FLAT WASHER 4		1				
062	266026-4	TAPPING SCREW BIND CT 4X12		1				
063	168426-3	BRAKE BAND		1				
064	125331-7	BRAKE DRUM ASSEMBLY		1	*			
064-1	123886-6	BRAKE DRUM ASSEMBLY	O	1				
065	253215-0	FLAT WASHER 8		1				
066	259033-4	RETAINING RING E TYPE 6		1				
067	195763-2	CHAIN TENSIONER SET		1				
D10		INC. 68-73						
068	452668-2	CLAMP SCREW BEDDING		1				
069	346300-7	TENSION SLIDE		1				

Please order the parts with part number.

Print Date 22/1/2024

Model No.UC4050A ELECTRIC CHAIN SAW 400MM

Item	Parts No.	Description	I/C	Qty	New/Old	Opt. 1	Opt. 2	Note
070	213594-8	O RING 7		1				
071	227744-9	HELICAL GEAR 18		1				
072	227743-1	HELICAL GEAR 11		1				
073	452667-4	GEAR COVER PROFESSIONAL		1				
074	266166-8	TAPPING SCREW CT 3X8		1				
075	346518-0	GUIDE PLATE		1				
076	266427-6	TAPPING SCREW 4X12		2				
077	142343-5	SPROCKET COVER COMPLETE		1				
078	454790-1	COVER		1				
079	142168-7	FLANGE NUT COMPLETE		2	*			
079-1	162492-2	FLANGE NUT COMPLETE	<	2	*			
079-2	144689-5	FLANGE NUT COMPLETE	O	2				
080	941001-8	FLAT WASHER 3		1				
081	324685-1	HOSE CLAMP		1				
A01	158024-1	HOOK COMPLETE		1				
A02	165202-6	GUIDE BAR 16		1	*			
A02-1	165202-6	GUIDE BAR 16	O	1				
A03	419242-9	CHAIN COVER		1				
A04A	196213-0	SAW CHAIN 16 SET		1	*			
A04B	196213-0	SAW CHAIN 16 SET		2	*			
A04-1A	196213-0	SAW CHAIN 16 SET	O	1				
A04-1B	196213-0	SAW CHAIN 16 SET	O	2				
A05	782023-7	WRENCH 13-16		1				
A06B	195089-2	CHAIN EDGER SET		1	*			
A06-1B	D-70948	FILE HOLDER SET 4.0MM(5/32")	O	1				
A07B	195090-7	GLOVES SET		1	*			
A08B	195091-5	SAFETY GOGGLES SET		1	*			
A09B	195093-1	CHAIN OIL SET		1				
A10B	823333-4	METAL CASE		1				
E01	805011-8	SOUND 103DB LABEL		1				

Please order the parts with part number.

Print Date 22/1/2024