

Model No.UH5530 HEDGE TRIMMER 550MM

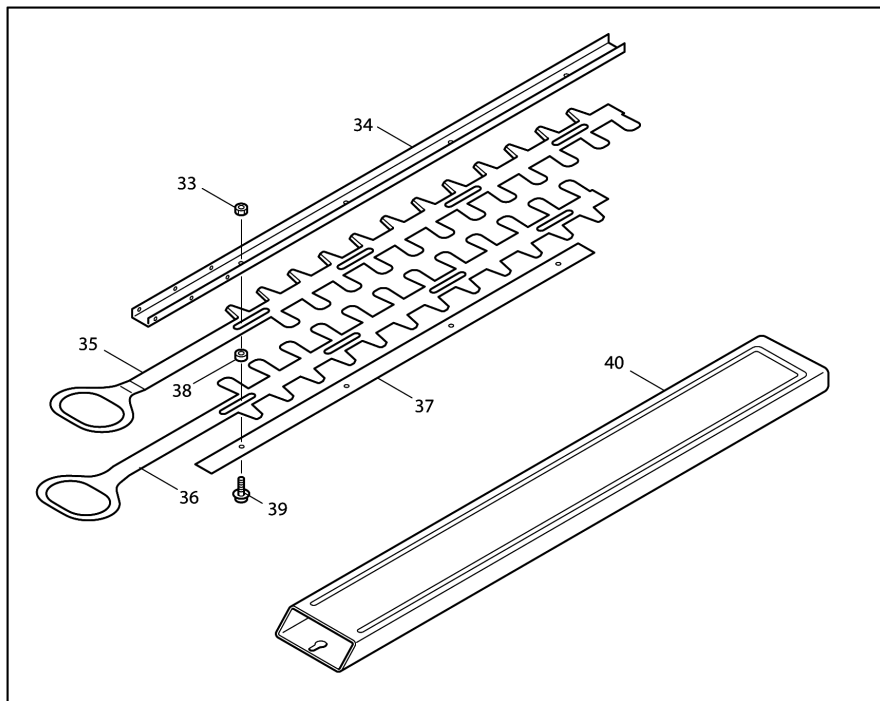
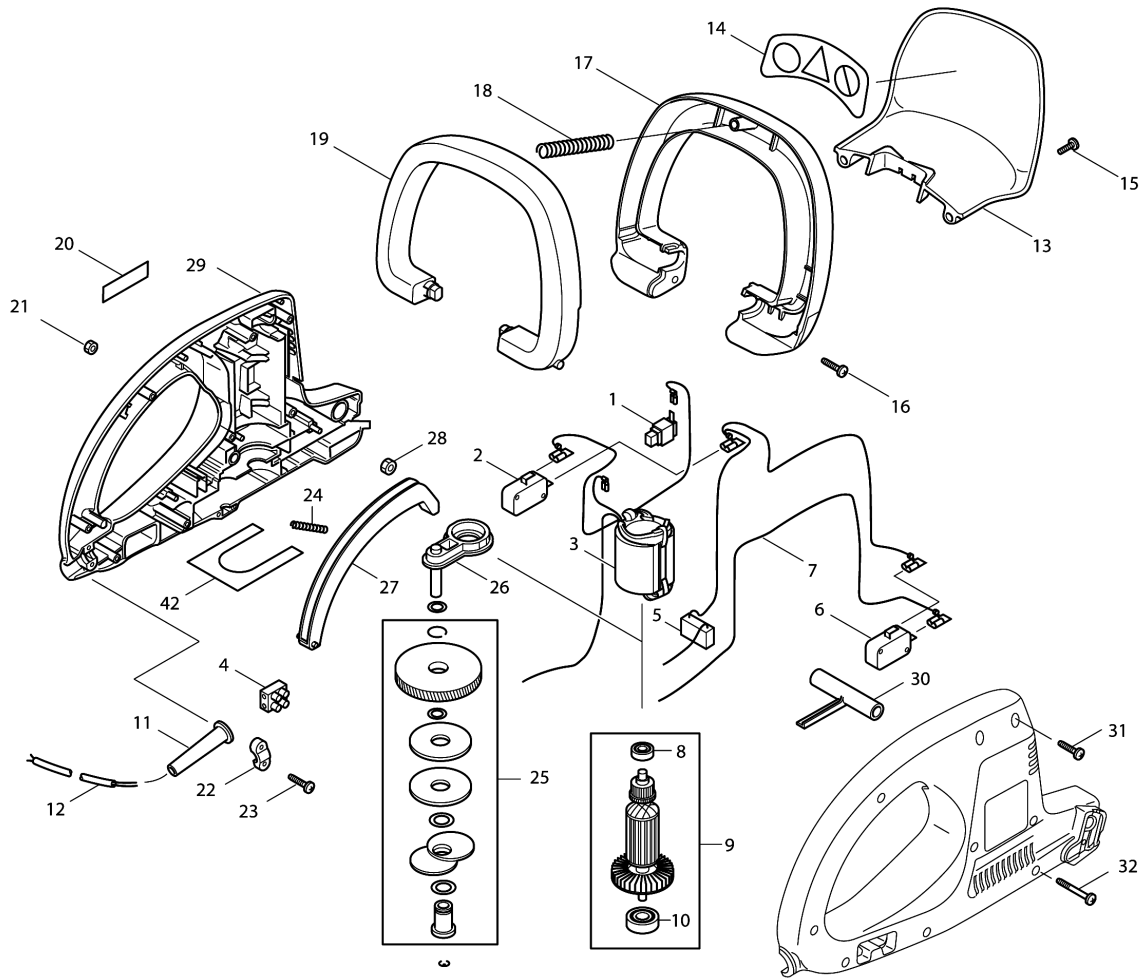

Model No.UH5530 HEDGE TRIMMER 550MM

Item	Parts No.	Description	I/C	Qty	New/Old	Opt. 1	Opt. 2	Note
001	957800410	CARBON BRUSH CPL.		1				
002	970001210	SWITCH		1	*			
002-1	970001210	SWITCH	O	1	*			
002-2	651948-5	SWITCH	O	1				
003	970801830	ARMATURE ASS'Y 230-240V		1				
004	970201220	SCREW WIRE CONNECTOR		1	*			
004-1	654531-7	TERMINAL BLOCK 2P	O	1				
005	970311291	CAPACITOR + REACT. COIL A		1				
006	970001210	SWITCH		1	*			
006-1	970001210	SWITCH	O	1	*			
006-2	651948-5	SWITCH	O	1				
007	970311250	CONNECTING CABLE		1	*			
007-1	632666-4	LEAD WIRE UNIT	O	1				
008	960101074	BALL BEARING		1	*			
008-1	211027-7	BALL BEARING 627ZZ	O	1				
009	970801830	ARMATURE ASS'Y 230-240V		1				
D10		INC. 8,10						
010	960101104	BALL BEARING 6000ZZ		1	*			
010-1	211062-5	BALL BEARING 6000ZZ	O	1				
011	204152010	CORD GUARD		1				
012	970102200	CABLE WITH PLUG		1				
013	221213111	HAND GUARD		1	*			
013-1	150638-2	PROTECTOR COMPLETE	O	1				
014	980114292	CAUTION LABEL		1				
015	913540205	SCREW M4X20		2				
016	917005250	SCREW M5X25		2	*			
016-1	911243-8	PAN HEAD SCREW M5X25	O	2				
017	221310110	TUBULAR HANDLE		1	*			
017-1	416101-8	GRIP	O	1				
018	221145110	PURESSURE SPRING		1	*			
018-1	233157-4	COMPRESSION SPRING 9	O	1				
019	221144110	FRONT GRIP SWITCH		1	*			
019-1	416099-9	SWITCH LEVER B	O	1				
020	980114296	LABEL		1	*			
020-1	819063-3	MAKITA LABEL	O	1				
021	920204000	HEXAGONAL NUT		2				
022	203152050	TRACTION RELIEF		1				
023	915635164	SELF-CUTTING SCREW M3.5X16		1	*			
023-1	266101-6	TAPPING SCREW BIND PT3.5X16	O	1				
024	221145120	PRESSURE SPRING		1	*			
024-1	233156-6	COMPRESSION SPRING 5	O	1				
025	221220011	GEAR ASSEMBLY		1				
026	221211010	GEAR PLATE WITH AXLE		1				
027	221144120	REAR GRIP SWITCH		1	*			

Please order the parts with part number.

Print Date 23/11/2023

Model No.UH5530 HEDGE TRIMMER 550MM

Item	Parts No.	Description	I/C	Qty	New/Old	Opt. 1	Opt. 2	Note
027-1	416098-1	SWITCH LEVER A	O	1				
028	920205000	HEX. NUT M5		2				
029	221110611	CASE, CPL.		1				
030	221144130	SWITCH FORK		1				
031	913540205	SCREW M4X20		8				
032	001230010	SCREW M4X35X25		2				
033	221233170	HEXAGONAL NUT M5		5	*			
033-1	252103-8	HEX. LOCK NUT M5-8	O	5				
034	221233111	MOUNTING BAR 40CM		1				
034A_	221233121	MOUNTING BAR 48CM		1				
034B_	221233131	MOUNTING BAR 55CM		1				
034C_	221233141	MOUNTING BAR 63CM		1				
035	221233210	SHEAR PLATE A 40CM		1				
035A_	221233220	SHEAR PLATE A		1				
035B_	221233230	SHEAR PLATE A		1				
035C_	221233240	SHEAR PLATE A		1				
036	221233310	SHEAR PLATE B		1				
036A_	221233320	SHEAR PLATE B		1				
036B_	221233330	SHEAR PLATE B		1				
036C_	221233340	SHEAR PLATE B		1				
037	221233410	SHEAR PLATE B		1				
037A_	221233420	BAR		1				
037B_	221233430	BAR		1				
037C_	221233440	BAR		1				
038	221233150	DISTANCE PIECE		5				
039	221233160	SCREW M5X14		5	*			
039-1	911218-7	PAN HEAD SCREW M5X14	O	5				
040	220233620	SHEATH 55-63CM		1	*			
040-1	415653-6	BLADE COVER	O	1				
041	221230611	SHEAR BLADE CPT. 40CM		1				
D10		INC. 33-40						
041A_	221230621	SHEAR BLADE CPT. 48CM		1				
D10		INC. 33A-37A,38,39,40A						
041B_	221230631	SHEAR BLADE CPT. 55CM		1				
D10		INC. 33B-37B,38,39,40B						
041C_	221230641	SHEAR BLADE CPT. 63CM		1				
D10		INC. 33C-37C,38,39,40C						
042	221229240	PLATE		1				

Please order the parts with part number.

Print Date 23/11/2023