

Makita

Power Planer

155 mm (6-1/8") MODEL 1805N

INSTRUCTION MANUAL

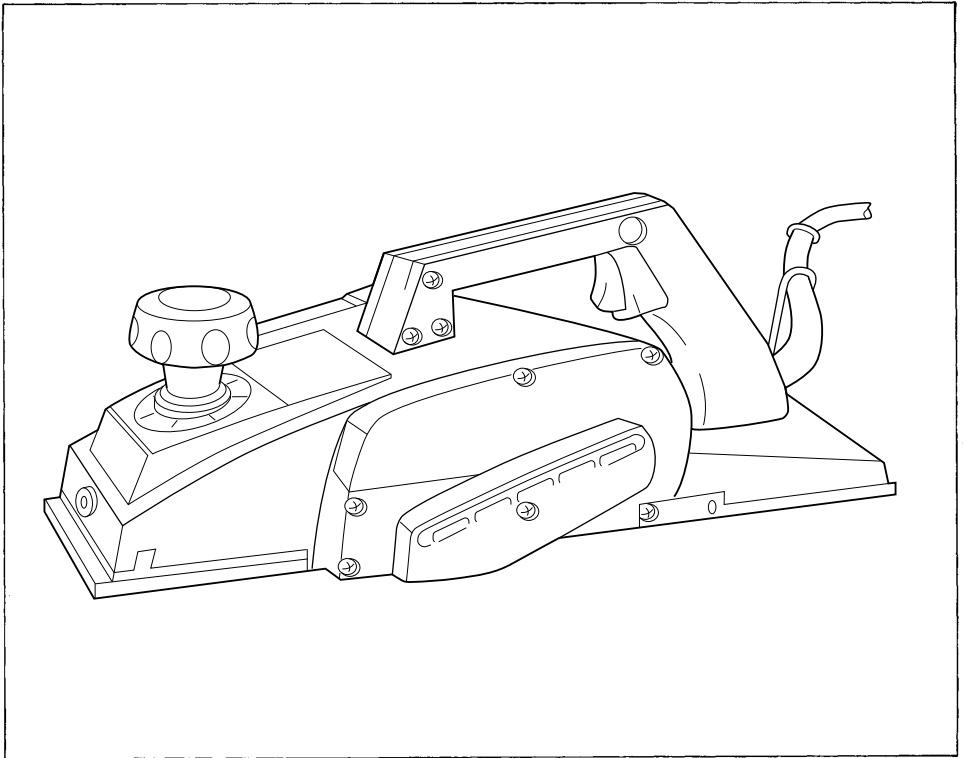

SPECIFICATIONS

| Planing width | Planing depth | No load speed (RPM) | Overall length | Net weight |
|-----------------|---------------|---------------------|------------------|-------------------|
| 155 mm (6-1/8") | 2 mm (1/16") | 15,000 | 445 mm (17-1/2") | 7.9 kg (17.4 lbs) |

* Manufacturer reserves the right to change specifications without notice.

* Note: Specifications may differ from country to country.

IMPORTANT SAFETY INSTRUCTIONS

WARNING: When using electric tools, basic safety precautions should always be followed to reduce the risk of fire, electric shock, and personal injury, including the following:

READ ALL INSTRUCTIONS.

1. **KEEP WORK AREA CLEAN.** Cluttered areas and benches invite injuries.
2. **CONSIDER WORK AREA ENVIRONMENT.** Don't use power tools in damp or wet locations. Keep work area well lit. Don't expose power tools to rain. Don't use tool in presence of flammable liquids or gases.
3. **KEEP CHILDREN AWAY.** All visitors should be kept away from work area. Don't let visitors contact tool or extension cord.
4. **STORE IDLE TOOLS.** When not in use, tools should be stored in dry, and high or locked-up place — out of reach of children.
5. **DON'T FORCE TOOL.** It will do the job better and safer at the rate for which it was intended.
6. **USE RIGHT TOOL.** Don't force small tool or attachment to do the job of a heavy-duty tool. Don't use tool for purpose not intended.
7. **DRESS PROPERLY.** Don't wear loose clothing or jewelry. They can be caught in moving parts. Rubber gloves and non-skid footwear are recommended when working outdoors. Wear protective hair covering to contain long hair.
8. **USE SAFETY GLASSES.** Also use face or dust mask if cutting operation is dusty.
9. **DON'T ABUSE CORD.** Never carry tool by cord or yank it to disconnect from receptacle. Keep cord from heat, oil, and sharp edges.
10. **SECURE WORK.** Use clamps or a vise to hold work. It's safer than using your hand and it frees both hands to operate tool.
11. **DON'T OVERREACH.** Keep proper footing and balance at all times.
12. **MAINTAIN TOOLS WITH CARE.** Keep tools sharp and clean for better and safer performance. Follow instructions for lubricating and changing accessories. Inspect tool cords periodically and if damaged, have repaired by authorized service facility. Inspect extension cords periodically and replace if damaged. Keep handles dry, clean, and free from oil and grease.
13. **DISCONNECT TOOLS.** When not in use, before servicing, and when changing accessories, such as blades, bits, cutters.
14. **REMOVE ADJUSTING KEYS AND WRENCHES.** Form habit of checking to see that keys and adjusting wrenches are removed from tool before turning it on.
15. **AVOID UNINTENTIONAL STARTING.** Don't carry plugged-in tool with finger on switch. Be sure switch is OFF when plugging in.
16. **OUTDOOR USE EXTENSION CORDS.** When tool is used outdoors, use only extension cords intended for use outdoors and so marked.

17. **STAY ALERT.** Watch what you are doing, use common sense. Don't operate tool when you are tired.
18. **CHECK DAMAGED PARTS.** Before further use of the tool, a guard or other part that is damaged should be carefully checked to determine that it will operate properly and perform its intended function. Check for alignment of moving parts, binding of moving parts, breakage of parts, mounting, and any other conditions that may affect its operation. A guard or other part that is damaged should be properly repaired or replaced by an authorized service center unless otherwise indicated elsewhere in this instruction manual. Have defective switches replaced by authorized service center. Don't use tool if switch does not turn it on and off.
19. **GUARD AGAINST ELECTRIC SHOCK.** Prevent body contact with grounded surfaces. For example; pipes, radiators, ranges, refrigerator enclosures.
20. **PROPER GROUNDING.** This tool should be grounded while in use to protect the operator from electric shock.
21. **EXTENSION CORDS:** Use only three-wire extension cords which have three-prong grounding-type plugs and three-pole receptacles which accept the tool's plug. Replace or repair damaged or worn cord immediately.

VOLTAGE WARNING: Before connecting the tool to a power source (receptacle, outlet, etc.) be sure the voltage supplied is the same as that specified on the nameplate of the tool. A power source with voltage greater than that specified for the tool can result in **SERIOUS INJURY** to the user — as well as damage to the tool. If in doubt, **DO NOT PLUG IN THE TOOL.** Using a power source with voltage less than the nameplate rating is harmful to the motor.

ADDITIONAL SAFETY RULES

- 1. Rags, cloth, cord, string and the like should never be left around the work area.**
- 2. Avoid cutting nails. Inspect for and remove all nails from the workpiece before operation.**
- 3. Handle the blades very carefully.**
- 4. Be sure the blade installation bolts are securely tightened before operation.**
- 5. Hold the tool firmly with both hands.**
- 6. Keep hands away from rotating parts.**
- 7. Before using the tool on an actual workpiece, let it run for a while. Watch for vibration or wobbling that could indicate poor installation or a poorly balanced blade.**
- 8. Make sure the blade is not contacting the workpiece before the switch is turned on.**
- 9. Wait until the blade attains full speed before cutting.**
- 10. Keep at least 200 mm (8") away from the tool at all times.**
- 11. Always switch off and wait for the blades to come to a complete stop before any adjusting.**
- 12. Never stick your finger into the chip chute. Chute may jam when cutting damp wood. Clean out chips with a stick.**
- 13. Do not leave the tool running. Operate the tool only when hand-held.**
- 14. When leaving the planer, switch off and set it with the front base up on a wooden block, so that the blades do not contact anything.**
- 15. Always change both blades or covers on the drum, otherwise the resulting imbalance will cause vibration and shorten tool life.**

SAVE THESE INSTRUCTIONS.

Removing or installing planer blades

CAUTION:

Always be sure that the tool is switched off and unplugged before removing or installing the blade.

To remove the blades on the drum, unscrew the four installation bolts with the socket wrench. The drum cover comes off together with the blades.

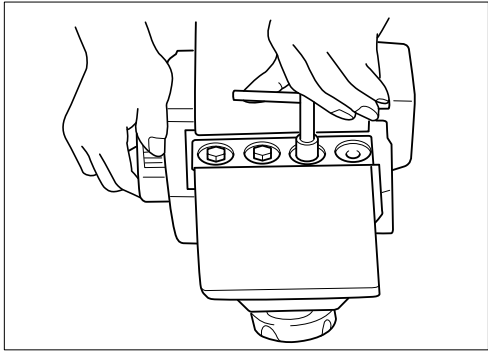

To install the blades, first clean out all chips or foreign matter adhering to the drum or blades. Use blades of the same dimensions and weight, or drum oscillation/vibration will result, causing poor planing action and, eventually, tool breakdown.

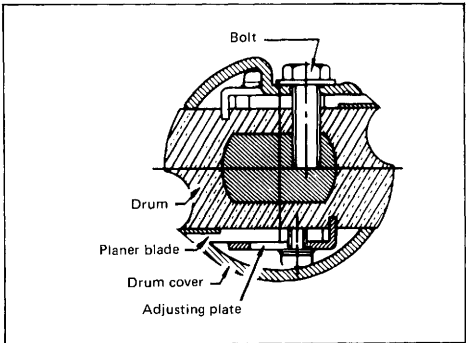

Place the blade on the gauge base so that the blade edge is perfectly flush with the inside edge of the gauge plate. Place the adjusting plate on the blade, then simply press in the heel of the adjusting plate flush with the back side of the gauge base and tighten two screws on the adjusting plate. Now slip the heel of the adjusting plate into the drum groove, then fit the drum cover on it. Tighten the four installation bolts evenly and alternately with the socket wrench.

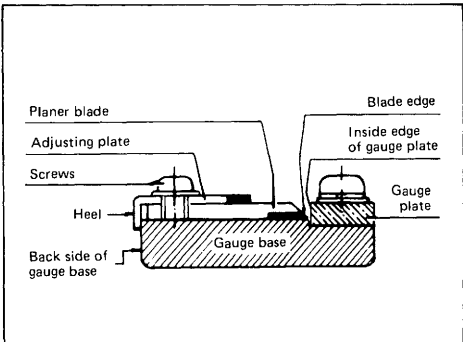

CAUTION:

Tighten the blade installation bolts carefully when attaching the blades to the tool. A loose installation bolt can be dangerous. Always check to see they are tightened securely.

For the correct planer blade setting

Your planing surface will end up rough and uneven, unless the blade is set properly and securely. The blade must be mounted so that the cutting edge is absolutely level, that is, parallel to the surface of the rear base. Below are some examples of proper and improper settings.

- (A) Front base (Movable shoe)
- (B) Rear base (Stationary shoe)

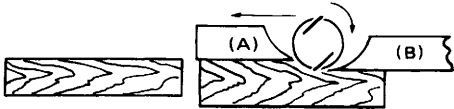
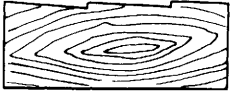
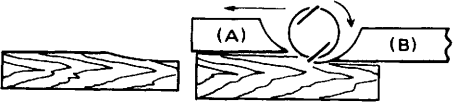
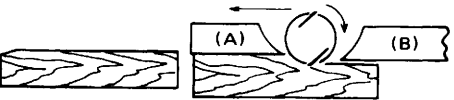
| | | |
|------------------|---|--|
| Correct setting |  | Although this side view cannot show it, the edges of the blades run perfectly parallel to the rear base surface. |
| Nicks in surface |  | Cause: One or both blades fails to have edge parallel to rear base line. |
| Gouging at start |  | Cause: One or both blade edges fails to protrude enough in relation to rear base line. |
| Gouging at end |  | Cause: One or both blade edges protrudes too far in relation to rear base line. |

Adjusting depth of cut

Depth of cut may be adjusted by simply turning the knob on the front of the tool.

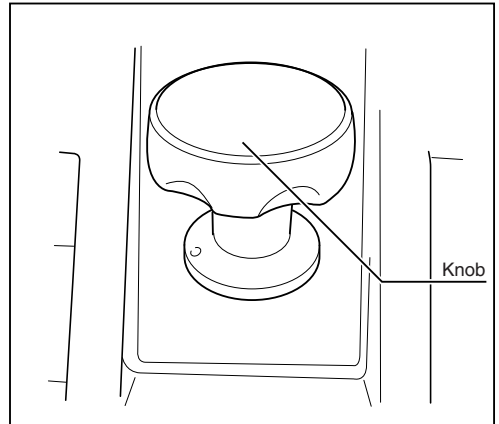

Switch action

To start the tool, simply pull the trigger. Release the trigger to stop. For continuous operation, pull the trigger and then push in the lock button. To stop the tool from the locked position, pull the trigger fully, then release it.

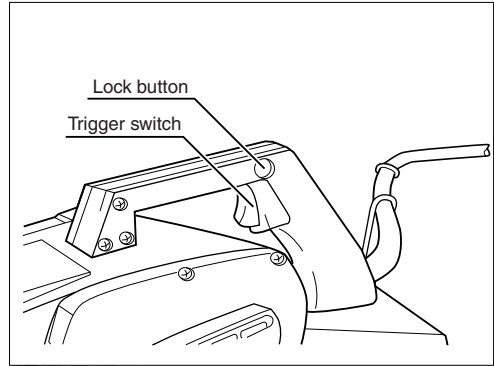

CAUTION:

Before plugging in the tool, always check to see that the trigger switch actuates properly and returns to the "OFF" position when released.

Planing operation

First, rest the tool front base flat upon the workpiece surface without the blades making any contact. Switch on and wait until the blades attain full speed. Then move the tool gently forward. Apply pressure on the front of tool at the start of planing, and at the back at the end of planing. Planing will be easier if you incline the workpiece in stationary fashion, so that you can plane somewhat downhill. The speed and depth of cut determine the kind of finish. The power planer keeps cutting at a speed that will not result in jamming by chips. For rough cutting, the depth of cut can be increased, while for a good finish you should reduce the depth of cut and advance the tool more slowly.

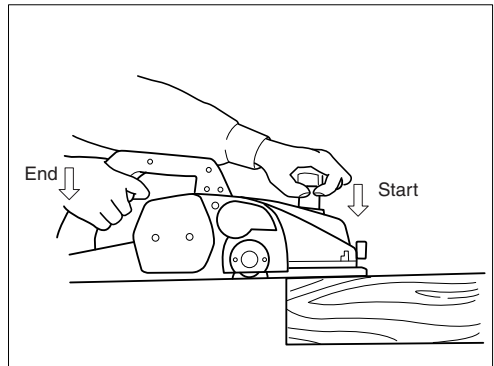

Use of nozzle assembly

Use of the special nozzle assembly will minimize chip scatter, making for a cleaner work area.

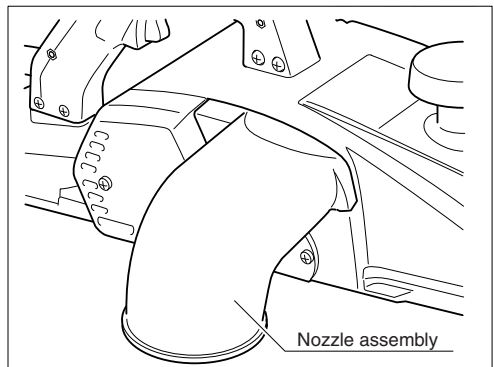

The nozzle assembly may be attached after the chip cover on the tool body is removed. Use the chip cover screws to fasten it in place.

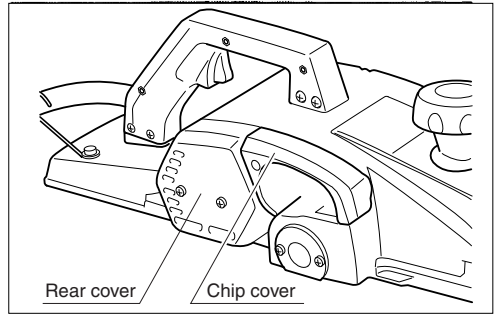

Sharpening planer blades

Always keep your blades sharp for the best performance possible. Use the sharpening holder to remove nicks and produce a fine edge.

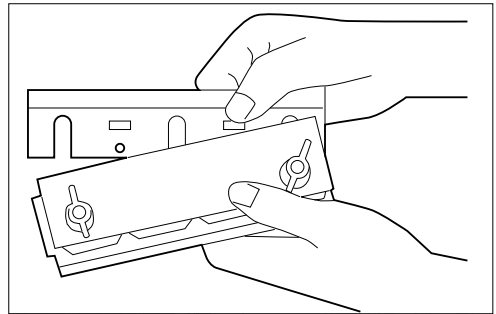

First, loosen the two wing nuts on the holder and insert the blades (A) and (B), so that they contact the sides (C) and (D). Then tighten the wing nuts.

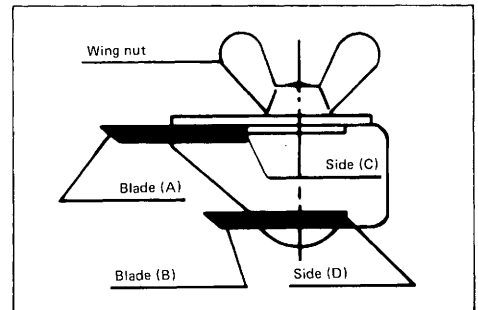

Immerse the dressing stone in water for 2 or 3 minutes before sharpening. Hold the holder so that the blades both contact the dressing stone for simultaneous sharpening at the same angle.

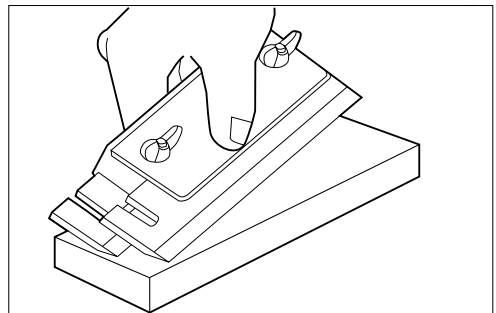

MAINTENANCE

CAUTION:

Always be sure that the tool is switched off and unplugged before attempting to perform inspection or maintenance.

Replacing carbon brushes

Remove and check the carbon brushes regularly. Replace when they wear down to the limit mark. Keep the carbon brushes clean and free to slip in the holders. Both carbon brushes should be replaced at the same time. Use only identical carbon brushes.

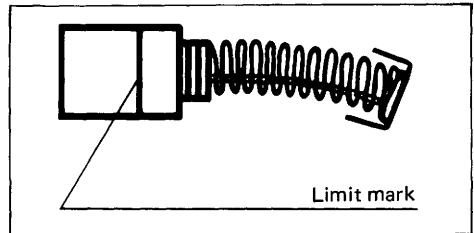

Use a screwdriver to remove the chip cover.

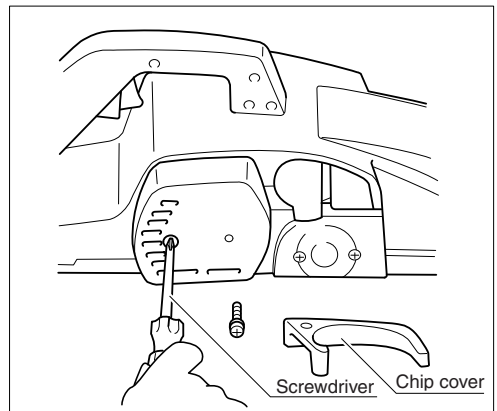

Use a screwdriver to remove the brush holder caps. Take out the worn carbon brushes, insert the new ones and secure the brush holder caps.

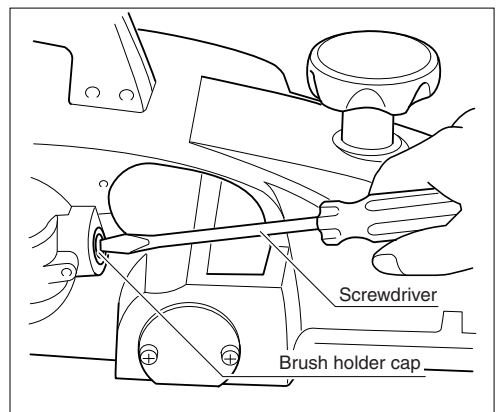

To maintain product SAFETY and RELIABILITY, repairs, any other maintenance or adjustment should be performed by Makita Authorized or Factory Service Centers, always using Makita replacement parts.

Makita Corporation

Anjo, Aichi, Japan

Made in Japan

883232D2