

INSTRUCTION MANUAL

Table Saw 2704

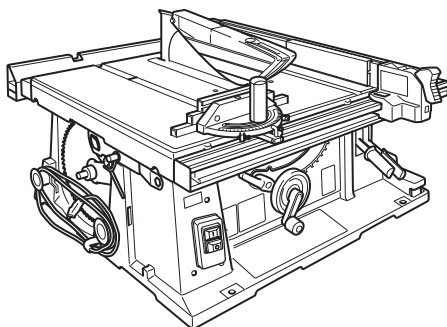

DOUBLE INSULATION



Read before use.





SPECIFICATIONS

Model		2704	
		(for European countries)	(for other than European countries)
Arbor hole		30 mm	25 mm and 25.4 mm
Blade diameter		260 mm	255 mm / 260 mm
Max. cutting capacities	90°	93 mm	91 mm / 93 mm
	45°	64 mm	63 mm / 64 mm
No load speed (min ⁻¹)		4,800	
Table size (L x W)		(665 mm - 1,045 mm) x (753 mm - 1,066 mm) with sub tables (R) and (back)	567 mm x (753 mm - 1,066 mm) with sub table (R)
Dimensions (L x W x H) with table(s) not extended		715 mm x 753 mm x 344 mm with sub tables (R) and (back)	665 mm x 753 mm x 344 mm with sub table (R)
Net weight		34.9 kg	29.5 kg
Safety class		□, II	

- Due to our continuing programme of research and development, the specifications herein are subject to change without notice.
- Specifications may differ from country to country.
- Weight according to EPTA-Procedure 01/2003

Symbols

The following show the symbols used for the equipment. Be sure that you understand their meaning before use.

	Read instruction manual.
	DOUBLE INSULATION
	Wear safety glasses.
	Do not place hand or fingers close to the blade.
	Only for EU countries Do not dispose of electric equipment together with household waste material! In observance of European Directive 2002/96/EC on waste electric and electronic equipment and its implementation in accordance with national law, electric equipment that have reached the end of their life must be collected separately and returned to an environmentally compatible recycling facility.

Intended use

The tool is intended for cutting in wood.

Power supply

The tool should be connected only to a power supply of the same voltage as indicated on the nameplate, and can only be operated on single-phase AC supply. They are double-insulated in accordance with European Standard and can, therefore, also be used from sockets without earth wire.

Noise

The typical A-weighted noise level determined according to EN61029:

Sound pressure level (L_{pA}): 94 dB (A)

Sound power level (L_{WA}): 107 dB (A)

Uncertainty (K): 3 dB (A)

Wear ear protection

For European countries only

EC Declaration of Conformity

We Makita Corporation as the responsible manufacturer declare that the following Makita machine(s):

Designation of Machine:

Table Saw

Model No./ Type: 2704

are of series production and

Conforms to the following European Directives:
2006/42/EC

And are manufactured in accordance with the following standards or standardised documents:

EN61029

The technical documentation is kept by our authorised representative in Europe who is:

Makita International Europe Ltd.

Michigan Drive, Tongwell,

Milton Keynes, Bucks MK15 8JD, England

21.4.2010



Tomoyasu Kato

Director

Makita Corporation

3-11-8, Sumiyoshi-cho,

Anjo, Aichi, 446-8502, JAPAN

SAFETY INSTRUCTIONS

WARNING! When using electric tools, basic safety precautions, including the following, should always be followed to reduce the risk of fire, electric shock and personal injury. Read all these instructions before operating this product and save these instructions.

For safe operations:

- 1. Keep work area clean.**
Cluttered areas and benches invite injuries.
- 2. Consider work area environment.**
Do not expose power tools to rain. Do not use power tools in damp or wet locations. Keep work area well lit. Do not use power tools where there is risk to cause fire or explosion.
- 3. Guard against electric shock.**
Avoid body contact with earthed or grounded surfaces (e.g. pipes, radiators, ranges, refrigerators).
- 4. Keep children away.**
Do not let visitors touch the tool or extension cord. All visitors should be kept away from work area.
- 5. Store idle tools.**
When not in use, tools should be stored in a dry, high or locked up place, out of reach of children.
- 6. Do not force the tool.**
It will do the job better and safer at the rate for which it was intended.
- 7. Use the right tool.**
Do not force small tools or attachments to do the job of a heavy duty tool. Do not use tools for purposes not intended; for example, do not use circular saws to cut tree limbs or logs.
- 8. Dress properly.**
Do not wear loose clothing or jewellery, they can be caught in moving parts. Rubber gloves and non-skid footwear are recommended when working outdoors. Wear protecting hair covering to contain long hair.
- 9. Use safety glasses and hearing protection.**
Also use face or dust mask if the cutting operation is dusty.
- 10. Connect dust extraction equipment.**
If devices are provided for the connection of dust extraction and collection facilities ensure these are connected and properly used.
- 11. Do not abuse the cord.**
Never carry the tool by the cord or yank it to disconnect it from the socket. Keep the cord away from heat, oil and sharp edges.
- 12. Secure work.**
Use clamps or a vice to hold the work. It is safer than using your hand and it frees both hands to operate the tool.
- 13. Do not overreach.**
Keep proper footing and balance at all times.
- 14. Maintain tools with care.**
Keep cutting tools sharp and clean for better and safer performance. Follow instructions for lubrication and changing accessories. Inspect tool cord periodically and if damaged have it repaired by an authorized service facility. Inspect extension cords periodically and replace, if damaged. Keep handles dry, clean and free from oil and grease.
- 15. Disconnect tools.**
When not in use, before servicing and when changing accessories such as blades, bits and cutters.
- 16. Remove adjusting keys and wrenches.**
Form the habit of checking to see that keys and adjusting wrenches are removed from the tool before turning it on.
- 17. Avoid unintentional starting.**
Do not carry a plugged-in tool with a finger on the switch. Ensure switch is off when plugging in.
- 18. Use outdoor extension leads.**
When tool is used outdoors, use only extension cords intended for outdoor use.
- 19. Stay alert.**
Watch what you are doing. Use common sense. Do not operate tool when you are tired.
- 20. Check damaged parts.**
Before further use of the tool, a guard or other part that is damaged should be carefully checked to determine that it will operate properly and perform its intended function. Check for alignment of moving parts, free running of moving parts, breakage of parts, mounting and any other conditions that may affect its operation. A guard or other part that is damaged should be properly repaired or replaced by an authorized service center unless otherwise indicated in this instruction manual. Have defective switches replaced by an authorized service facility. Do not use the tool if the switch does not turn it on and off.
- 21. Warning.**
The use of any accessory or attachment, other than those recommended in this instruction manual or the catalog, may present a risk of personal injury.
- 22. Have your tool repaired by a qualified person.**
This electric tool is in accordance with the relevant safety requirements. Repairs should only be carried out by qualified persons using original spare parts, otherwise this may result in considerable danger to the user.

ADDITIONAL SAFETY RULES FOR TOOL

SAVE THESE INSTRUCTIONS.

- 1. Wear eye protection.**
- 2. Do not use the tool in presence of flammable liquids or gases.**
- 3. NEVER use the tool with an abrasive cut-off wheel installed.**
- 4. Check the blade carefully for cracks or damage before operation. Replace cracked or damaged blade immediately.**
- 5. Use only saw blades recommended by the manufacturer and which conform to EN847-1, and observe that the riving knife must not be thicker than the width of the cut by the saw blade and not thinner than the body of the blade.**
- 6. Always use accessories recommended in this manual. Use of improper accessories such as abrasive cut-off wheels may cause an injury.**
- 7. Select the correct saw blade for the material to be cut.**
- 8. Do not use saw blades manufactured from high speed steel.**
- 9. To reduce the emitted noise, always be sure that the blade is sharp and clean.**
- 10. Use correctly sharpened saw blades. Observe the maximum speed marked on the saw blade.**
- 11. Clean the spindle, flanges (especially the installing surface) and hex nut before installing the blade. Poor installation may cause vibration/wobbling or slippage of the blade.**

12. Use saw-blade guard and riving knife for every operation for which it can be used, including all through sawing operations. Always install the blade guard following the instructions out-lined in this manual. Through sawing operations are those in which the blade cuts completely through the workpiece as in ripping or cross cutting. NEVER use the tool with a faulty blade guard or secure the blade guard with a rope, string, etc. Any irregular operation of the blade guard should be corrected immediately.
13. Immediately reattach the guard and riving knife after completing an operation which requires removal of the guard.
14. Do not cut metal objects such as nails and screws. Inspect for and remove all nails, screws and other foreign material from the workpiece before operation.
15. Remove wrenches, cut-off pieces, etc. from the table before the switch is turned on.
16. NEVER wear gloves during operation.
17. Keep hands out of the line of the saw blade.
18. NEVER stand or permit anyone else to stand in line with the path of the saw blade.
19. Make sure the blade is not contacting the riving knife or workpiece before the switch is turned on.
20. Before using the tool on an actual workpiece, let it run for a while. Watch for vibration or wobbling that could indicate poor installation or a poorly balanced blade.
21. The tool should not be used for slotting, rabbetting or grooving.
22. Replace table insert when worn.
23. NEVER make any adjustments while tool is running. Disconnect tool before making any adjustments.
24. Use a push stick when required. Push sticks MUST be used for ripping narrow workpieces to keep your hands and fingers well away from the blade.
25. Always store the push-stick when it is not in use.
26. Pay particular attention to instructions for reducing risk of KICKBACK. KICKBACK is a sudden reaction to a pinched, bound or misaligned saw blade. KICKBACK causes the ejection of the workpiece from the tool back towards the operator. KICKBACKS CAN LEAD TO SERIOUS PERSONAL INJURY. Avoid KICKBACKS by keeping the blade sharp, by keeping the rip fence parallel to the blade, by keeping the riving knife and blade guard in place and operating properly, by not releasing the workpiece until you have pushed it all the way past the blade, and by not ripping a workpiece that is twisted or warped or does not have a straight edge to guide along the fence.
27. Do not perform any operation freehand. Freehand means using your hands to support or guide the workpiece, in lieu of a rip fence or miter gauge.
28. NEVER reach around or over saw blade. NEVER reach for a workpiece until the saw blade has completely stopped.
29. Avoid abrupt, fast feeding. Feed as slowly as possible when cutting hard workpieces. Do not bend or twist workpiece while feeding. If you stall or jam the blade in the workpiece, turn the tool off immediately. Unplug the tool. Then clear the jam.
30. NEVER remove cut-off pieces near the blade or touch the blade guard while the blade is running.
31. Knock out any loose knots from workpiece BEFORE beginning to cut.
32. Do not abuse cord. Never yank cord to disconnect it from the receptacle. Keep cord away from heat, oil, water and sharp edges.
33. Some dust created from operation contains chemicals known to cause cancer, birth defects or other reproductive harm. Some examples of these chemicals are:
 - lead from lead-based-painted material and,
 - arsenic and chromium from chemically-treated lumber.
 - Your risk from these exposures varies, depending on how often you do this type of work. To reduce your exposure to these chemicals: work in a well ventilated area and work with approved safety equipment, such as those dust masks that are specially designed to filter out microscopic particles.
34. Connect the tool to a dust collecting device when sawing.
35. The guard can be lifted during workpiece setup and for ease of cleaning. Always make sure that guard hood is down and flat against sawtable before plugging in the tool.

SAVE THESE INSTRUCTIONS.

INSTALLATION

Positioning table saw

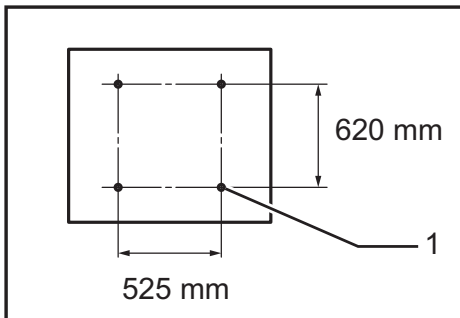

► 1. Hole diameter 8 mm

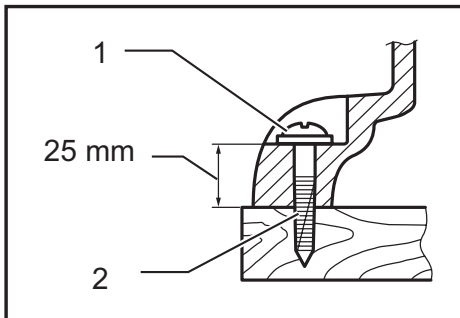

► 1. 1.6 mm Std. washer 2. No.10 wood screw 40 mm min. length

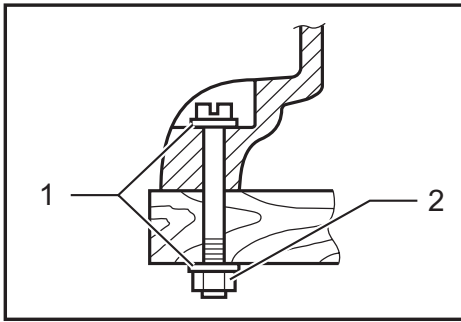

- 1. 6 mm Std. washer 2. 6 mm Mounting bolt & Nut tighten securely

Locate the table saw in a well lit and level area where you can maintain good footing and balance. It should be installed in an area that leaves enough room to easily handle the size of your workpieces. The table saw should be secured with four screws or bolts to the work bench or table saw stand using the holes provided in the bottom of the table saw. When securing the table saw on the work bench, make sure that there is an opening in the top of the work bench the same size as the opening in the bottom of the table saw so the sawdust can drop through. If during operation there is any tendency for the table saw to tip over, slide or move, the work bench or table saw stand should be secured to the floor.

Storing accessories

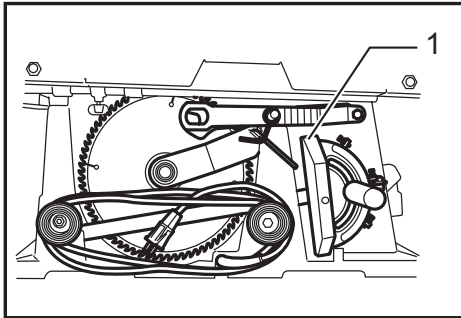

- 1. Miter gauge

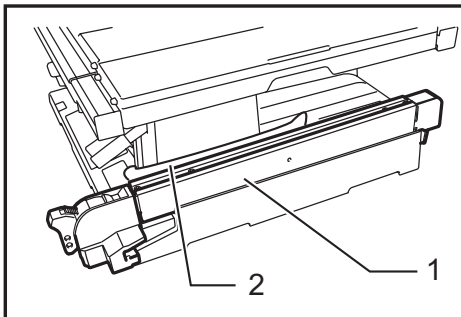

- 1. Rip fence 2. Push stick

The miter gauge, blade and wrenches can be stored on the left side of the base and the rip fence can be stored at the right side of the base.

FUNCTIONAL DESCRIPTION

⚠ CAUTION:

- Always be sure that the tool is switched off and unplugged before adjusting or checking function on the tool.

Adjusting the depth of cut

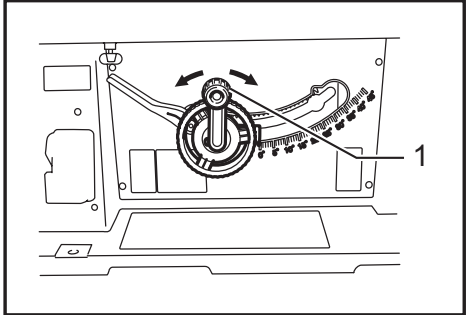

- 1. Handle

The depth of cut may be adjusted by turning the handle. Turn the handle clockwise to raise the blade or counterclockwise to lower it.

NOTE:

- Use a shallow depth setting when cutting thin materials in order to obtain a cleaner cut.

Adjusting the bevel angle

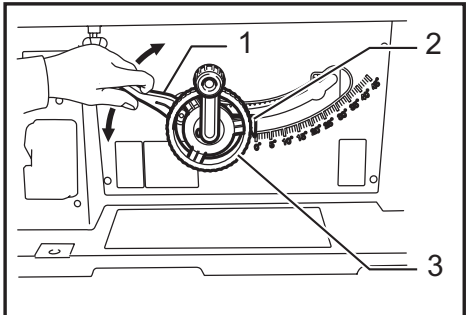

- 1. Lock lever 2. Arrow pointer 3. Handwheel

Loosen the lock lever counterclockwise and turn the handwheel until the desired angle ($0^\circ - 45^\circ$) is obtained. The bevel angle is indicated by the arrow pointer. After obtaining the desired angle, tighten the lock lever clockwise to secure the adjustment.

⚠ CAUTION:

- After adjusting the bevel angle, be sure to tighten the lock lever securely.

Adjusting positive stops

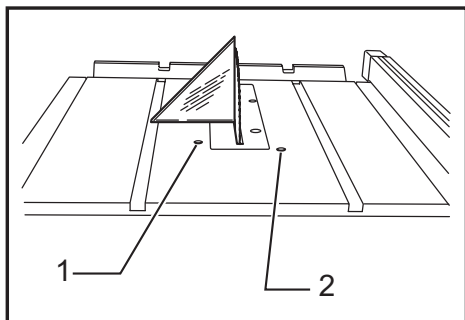

► 1. 90° Adjusting screw 2. 45° Adjusting screw

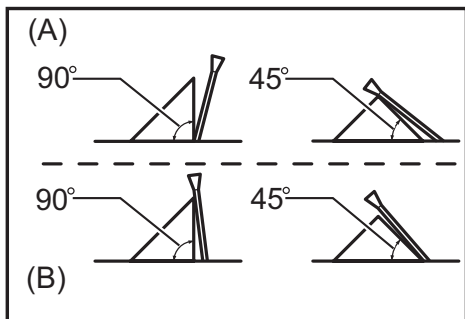

The tool is equipped with positive stops at 90° and 45° to the table surface. To check and adjust the positive stops, proceed as follows:

Move the handwheel as far as possible by turning it. Place a triangular rule on the table and check to see if the blade is at 90° or 45° to the table surface. If the blade is at an angle shown in Fig. A, turn the adjusting screws clockwise; if it is at an angle shown in Fig. B, turn the adjusting screws counterclockwise to adjust the positive stops.

After adjusting the positive stops, set the blade at 90° to the table surface. Then adjust the arrow pointer so that its right edge is aligned to the 0° graduation.

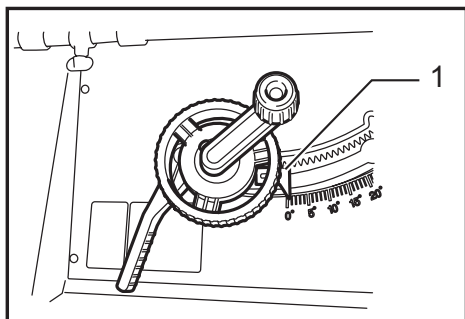

► 1. Arrow pointer

Switch action

For the lever type switch

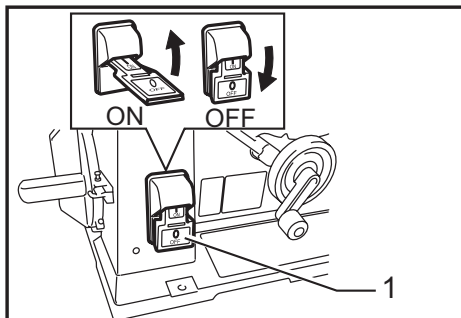

► 1. Switch

CAUTION:

- Before plugging in the tool, always be sure that the tool is switched off.

To start the tool, raise the switch lever. To stop it, lower the switch lever.

The hinged switch lever plate can be locked by passing padlock through the hasp on the left hand side.

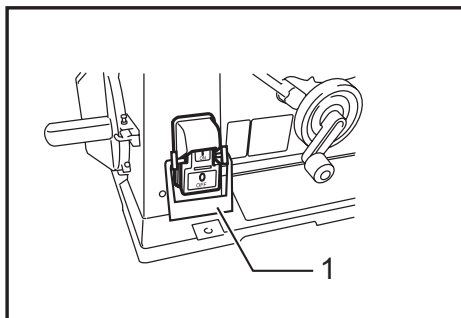

► 1. Padlock

For the button type switch

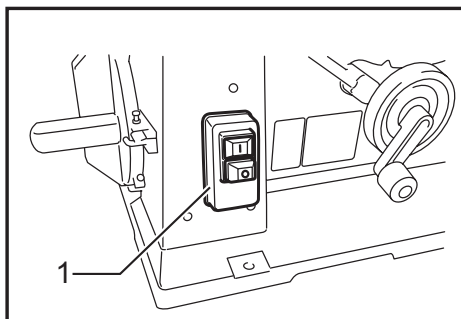

► 1. Switch

⚠ CAUTION:

- Before operation, make sure that the tool is turned on and off.

To start the tool, press the ON (I) button.

To stop it, press the OFF (O) button.

Sub table (R)

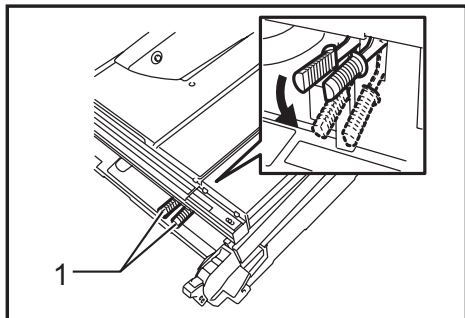

► 1. Lever

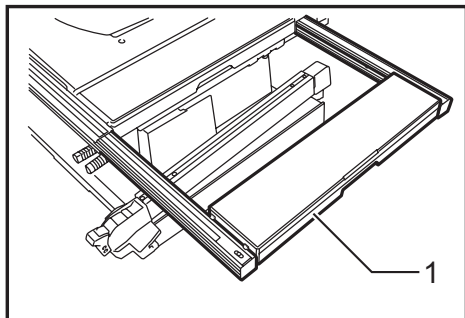

► 1. Sub table (R)

This tool is provided with the sub table (R) on the right side of the main table. To use the sub table (R), raise both levers on the front right side, pull out the table (R) fully and then lower the levers to secure it.

When using the sub table (R), locate the scale plate on the sub table after loosening the screw on it with a screwdriver so that it becomes successive with the scale plate on the main table.

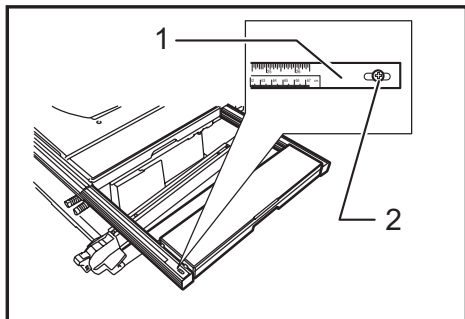

► 1. Scale plate 2. Screw

Sub table (back)

(optional accessory for other than European countries)

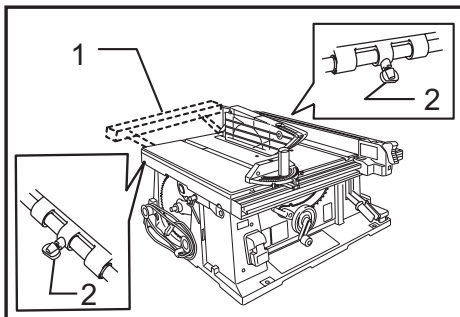

► 1. Sub table (back) 2. Screw

To use the sub table (back), loosen the screws on the left and right hand sides under the table and pull it out backwards to the desired length. At the desired length, tighten the screw securely.

NOTE:

- When using the sub table (back) during use of the rip fence, pull out the sub table (back) more than 50 mm so that it does not hit against the top end of the rip fence.

Sub table (L) (optional accessory)

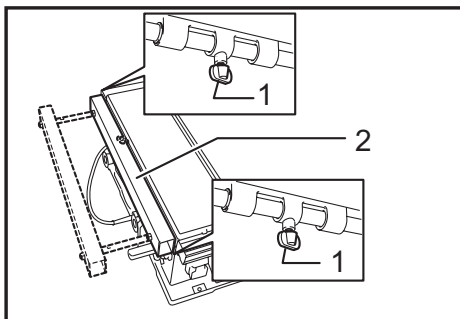

► 1. Screw 2. Sub table (L)

Sub table (L) (optional accessory) can be installed on the left side of the table to obtain wider space.

ASSEMBLY

⚠ CAUTION:

- Always be sure that the tool is switched off and unplugged before carrying out any work on the tool.

The tool is shipped from the factory with the saw blade and blade guard not in the installed condition. Assemble as follows:

Installing or removing saw blade

⚠ CAUTION:

- Always be sure that the tool is switched off and unplugged before installing or removing the blade.
- Use only the Makita socket wrench provided to install or remove the blade. Failure to do so may result in overtightening or insufficient tightening of the hex bolt. This could cause an injury.
- Use the following saw blade. Do not use saw blades which do not comply with the characteristics specified in these instructions.

For Model	Max. dia.	Min. dia.	Blade thickness	Kerf
2704	260 mm	230 mm	1.8 mm or less	2 mm or more

⚠ CAUTION:

- Check the arbor hole diameter of the blade before installing the blade. Always use the correct ring for the arbor hole of the blade you intend to use.

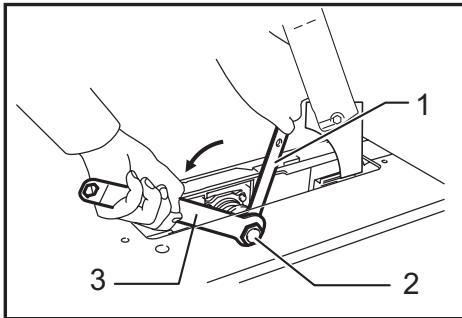

► 1. Offset wrench 2. Hex nut 3. Wrench

Remove the table insert on the table. Hold the outer flange with the offset wrench and loosen the hex nut counterclockwise with the wrench. Then remove the outer flange.

Assemble the inner flange, ring, saw blade, outer flange and hex nut onto the arbor, making sure that the teeth of the blade are pointing down at the front of the table. Always install the hex nut with its recessed side facing the outer flange.

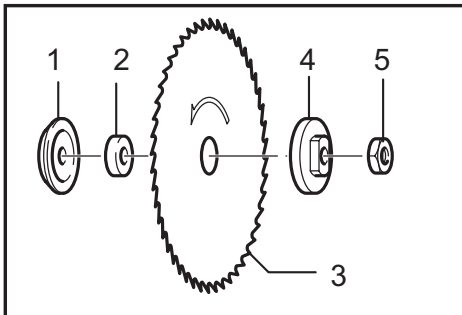

► 1. Inner flange 2. Ring 3. Saw blade 4. Outer flange
5. Hex nut

For all countries other than European countries

⚠ CAUTION:

- The silver ring 25.4 mm in outer diameter is factory-installed onto the spindle. The black ring 25 mm in outer diameter is included as standard equipment. Before mounting the blade onto the spindle, always be sure that the correct ring for the arbor hole of the blade you intend to use is installed onto the spindle.

For European countries

⚠ CAUTION:

- The ring 30 mm in outer diameter is factory-installed between the inner and outer flanges.
- Keep the flange surface clean of dirt or other adhering matter; it could cause blade slippage. Be sure that the blade is installed so that the teeth are aligned in the cutting (turning) direction.

To secure the blade in place, hold the outer flange with the offset wrench, then tighten the hex nut clockwise with the wrench. **BE SURE TO TIGHTEN THE HEX NUT SECURELY.**

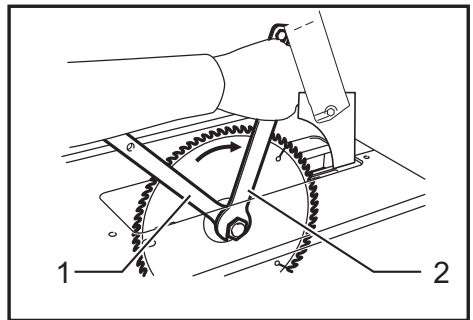

► 1. Offset wrench 2. Wrench

⚠ CAUTION:

- Be sure to hold the hex nut carefully with the wrench. If your grip should slip, the wrench may come off the hex nut, and your hand could strike the sharp blade edges.

Installing blade guard

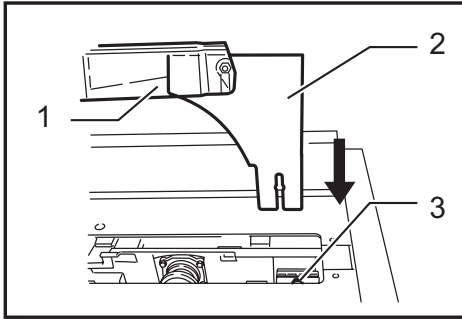

► 1. Blade guard 2. Riving knife 3. Blade guard mounting portion (stay)

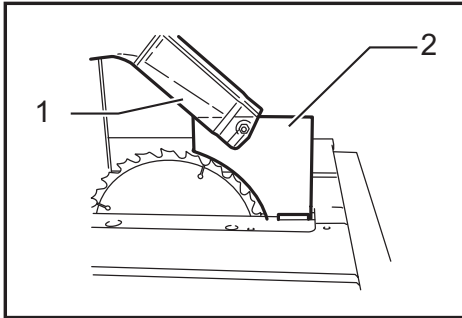

► 1. Blade guard 2. Riving knife

⚠ CAUTION:

- Before installing the blade guard, adjust the depth of cut to its maximum elevation.

For non-European type blade guard

Remove the center cover. Insert the riving knife into the blade guard mounting portion (stay). Tighten the hex bolts (A) with the provided wrench.

For European type blade guard

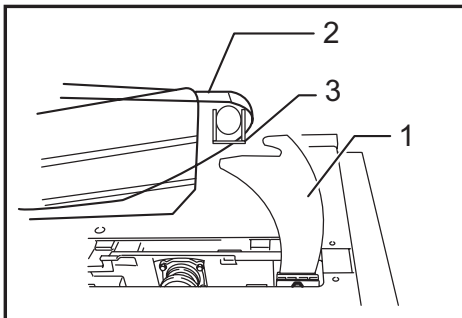

► 1. Riving knife 2. Blade guard 3. Lever

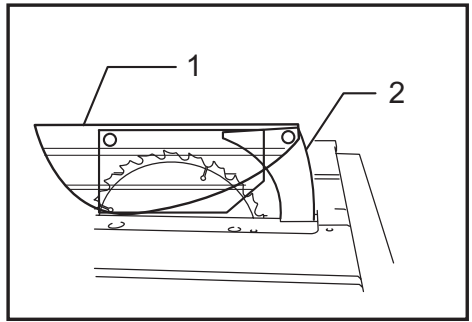

► 1. Blade guard 2. Riving knife

Remove the center cover. Insert the riving knife into the blade guard mounting portion (stay). Tighten the hex bolts (A) with the provided wrench.

Place the blade guard into the groove on the riving knife. Secure the blade guard by pivoting the lever on the blade guard.

For both European and non-European type blade guards

The riving knife installing location is factory-adjusted so that the blade and riving knife will be in a straight line. However, if they are not in a straight line, loosen the hex bolts (B) and adjust the blade guard mounting portion (stay) so that the riving knife is aligned directly behind the blade. Then tighten the hex bolts (B) to secure the stay.

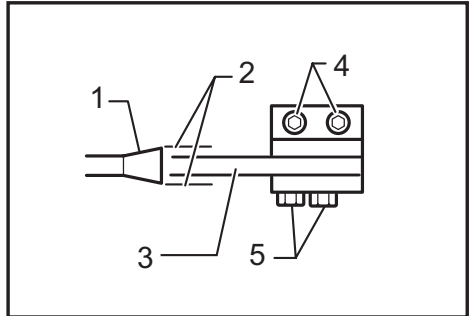

► 1. Blade 2. These two clearances should be equal. 3. Riving knife 4. Hex bolts (B) 5. Hex bolts (A)

⚠ CAUTION:

- If the blade and riving knife are not aligned properly, a dangerous pinching condition may result during operation. Make sure they are properly aligned. You could suffer serious personal injury while using the tool without a properly aligned riving knife.
- NEVER make any adjustments while tool is running. Disconnect the tool before making any adjustments.
- Don't remove the riving knife.

There must be a clearance of about 4 - 5 mm between the riving knife and the blade teeth. Loosen the hex bolts (A), adjust the riving knife accordingly and tighten the hex bolts (A) securely. Attach the table insert on the table, then check to see that the blade guard works smoothly before cutting.

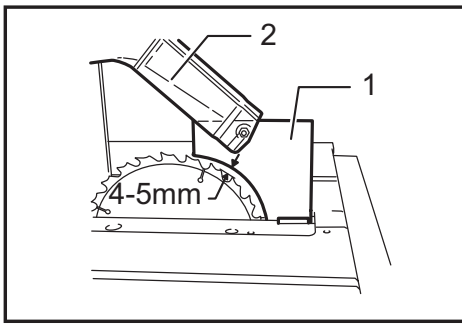

► 1. Riving knife 2. Blade guard

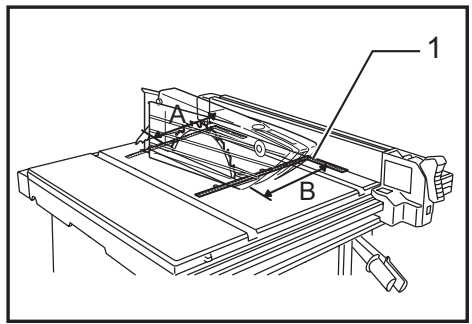

► 1. Scale

Installing and adjusting rip fence

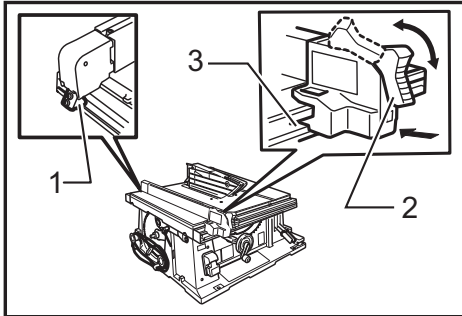

► 1. Hook 2. Knob 3. Guide rail

1) Fit the hook on the tip of the rip fence into the far guide rail on the table or sub table (R) and install and push the rip fence forward so that the fence holder engages with the nearest guide rail. To slide the rip fence on the guide rail sideways, pivot the knob on the fence holder to the half way of its travel. To secure the rip fence, pivot fully the knob on the fence holder.

2) To slide the rip fence on the guide rail sideways, return the knob on the fence holder fully without pulling the lever on the knob.

3) To remove it, pull the lever on the knob and pivot the knob fully forward while pulling the lever.

To check to be sure that the rip fence is parallel with the blade, secure the rip fence 2 - 3 mm from the blade. Raise the blade up to maximum elevation. Mark one of the blade teeth with a crayon. Measure the distance (A) and (B) between the rip fence and blade. Take both measurements using the tooth marked with the crayon. These two measurements should be identical. If the rip fence is not parallel with the blade, proceed as follows:

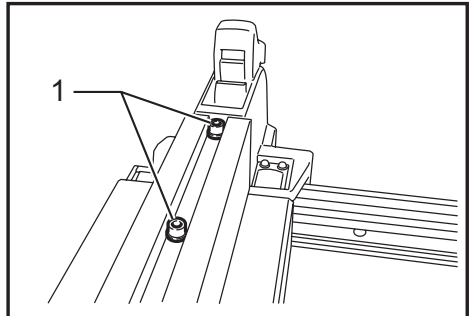

► 1. Hex bolts

1. Position the rip fence in the sliding position.
2. Loosen the two hex bolts on the rip fence with the hex wrench provided.
3. Adjust the rip fence until it becomes parallel with the blade.
4. Pivot down the knob on the rip fence toward the operator.
5. Tighten the two hex bolts on the rip fence.

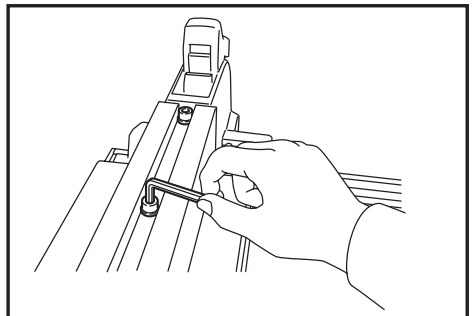

⚠ CAUTION:

- Be sure to adjust the rip fence so that it is parallel with the blade, or a dangerous kickback condition may occur.

When the rip fence cannot be secured solidly, adjust it according to the following procedure.

- (1) Set the rip fence on the table and then pivot the knob on the half way of its travel (moving position). Tighten the screw (A) until the rip fence is immobilized. Then loosen a 1/4 to 1/2 turn.

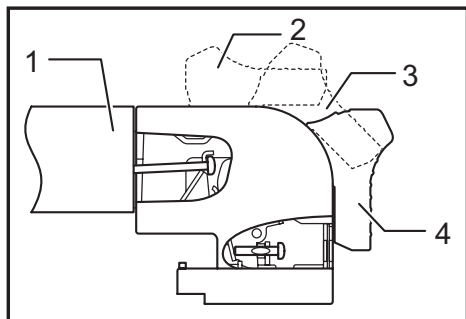

- ▶ 1. Rip fence 2. Released position 3. Moving position 4. Lock position

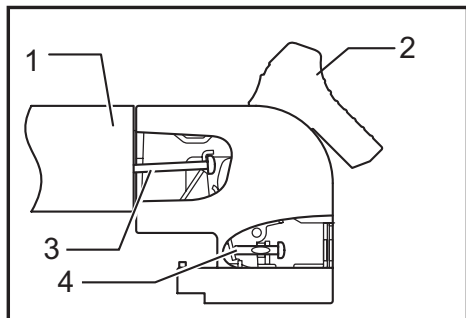

- ▶ 1. Rip fence 2. Moving position 3. Screw (B) 4. Screw (A)

- (2) Tighten the screw (B) fully and then loosen about 2 full revolutions.
- (3) Lock the rip fence by fully pivoting the knob on the fence holder (lock position).
- (4) Make sure that the rip fence can be installed and removed in the original position (released position).
- (5) Make sure that the rip fence can be slid smoothly with no wobble when the knob is on half way of its travel.

⚠ CAUTION:

- Be careful not to tighten screws with more than tightening amount specified in the above instructions. Failure to do so may damage the fastened parts.

Bring the rip fence up flush against the side of the blade. Make sure that the guideline on the fence holder points to the 0 graduation. If the guideline does not point to the 0 graduation, loosen the screw on the scale plate and adjust the scale plate.

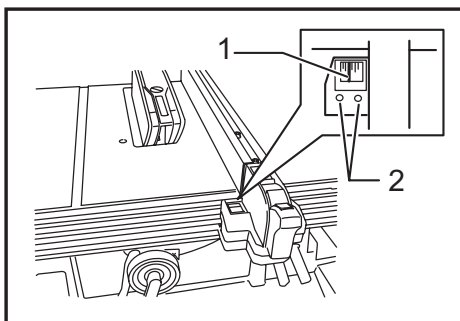

- ▶ 1. Guideline 2. Screws

Connecting to vacuum cleaner

Cleaner operations can be performed by connecting the tool to Makita vacuum cleaner or dust collector.

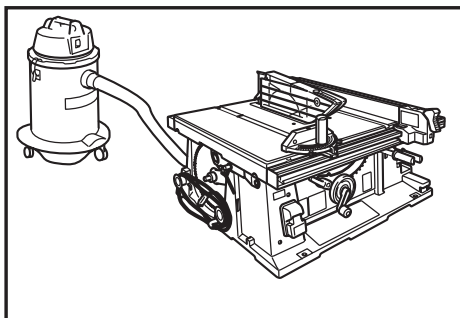

OPERATION

⚠ CAUTION:

- Always use "work helpers" such as push sticks and push blocks when there is a danger that your hands or fingers will come close to the blade.
- Always hold the workpiece firmly with the table and the rip fence or miter gauge. Do not bend or twist it while feeding. If the workpiece is bent or twisted, dangerous kickbacks may occur.
- NEVER withdraw the workpiece while the blade is running. If you must withdraw the workpiece before completing a cut, first switch the tool off while holding the workpiece firmly. Wait until the blade has come to a complete stop before withdrawing the workpiece. Failure to do so may cause dangerous kickbacks.
- NEVER remove cut-off material while the blade is running.
- NEVER place your hands or fingers in the path of the saw blade. Be especially careful with bevel cuts.
- Always secure the rip fence firmly, or dangerous kickbacks may occur.
- Always use "work helpers" such as push sticks and push blocks when cutting small or narrow workpieces.

Work helpers

Push sticks, push blocks or auxiliary fence are types of "work helpers". Use them to make safe, sure cuts without the need for the operator to contact the blade with any part of the body.

Push block

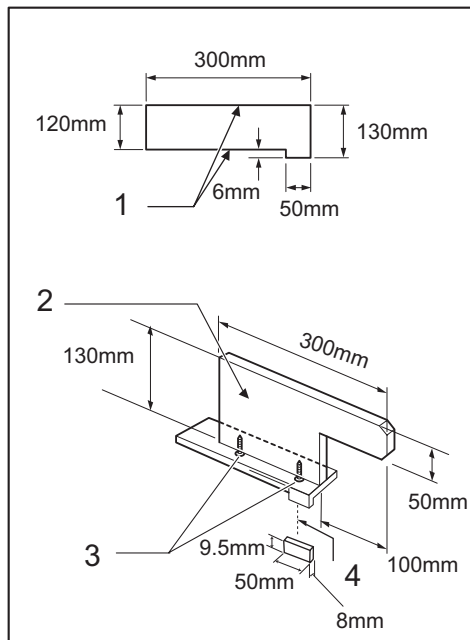

- 1. Face/edge parallel 2. Handle 3. Wood screw
4. Glue together

Use a 19 mm piece of plywood.

Handle should be in center of plywood piece. Fasten with glue and wood screws as shown. Small piece 9.5 mm x 8 mm x 50 mm of wood must always be glued to plywood to keep the blade from dulling if the operator cuts into push block by mistake. (Never use nails in push block.)

Auxiliary fence

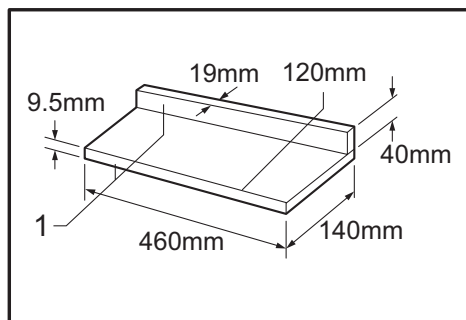

- 1. Face/edge parallel

Make auxiliary fence from 9.5 mm and 19 mm plywood pieces.

Wood facing (rip fence)

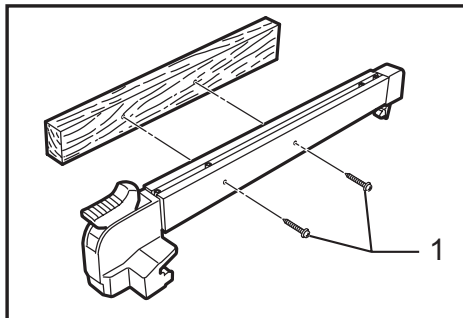

- 1. No. 10 wood screws (long enough to penetrate halfway into facing)

A wood facing should be used for operations when the blade comes close to the rip fence. Wood facing for the rip fence should be the same size as the rip fence. Make sure the bottom of facing is flush with the table surface.

Ripping

CAUTION:

- When ripping, remove the miter gauge from the table.
- When cutting long or large workpieces, always provide adequate support behind the table. DO NOT allow a long board to move or shift on the table. This will cause the blade to bind and increase the possibility of kickback and personal injury. The support should be at the same height as the table.

1. Adjust the depth of cut a bit higher than the thickness of the workpiece.

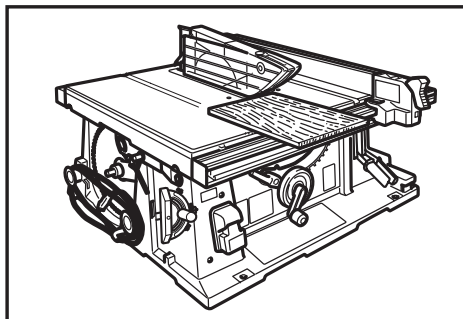

2. Position the rip fence to the desired width of rip and lock in place by pivoting the grip. Before ripping, make sure the rear end of the rip fence is secured firmly. If it is not secured enough, follow the procedures in the section titled "Installing and adjusting rip fence".
3. Turn the tool on and gently feed the workpiece into the blade along with the rip fence.
- (1) When the width of rip is 150 mm and wider, carefully use your right hand to feed the workpiece. Use your left hand to hold the workpiece in position against the rip fence.

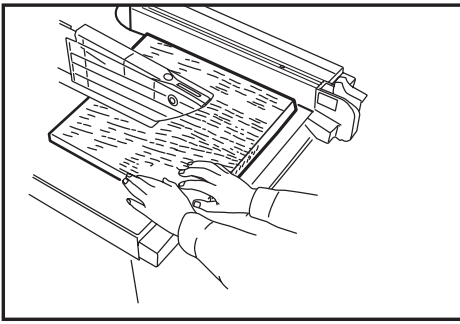

- (2) When the width of rip is 65 mm - 150 mm wide, use the push stick to feed the workpiece.

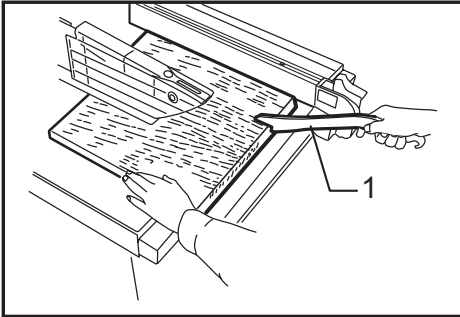

- 1. Push stick

- (3) When the width of rip is narrower than 65 mm, the push stick cannot be used because the push stick will strike the blade guard. Use the auxiliary fence and push block. Attach the auxiliary fence to the rip fence with two "C" clamps.

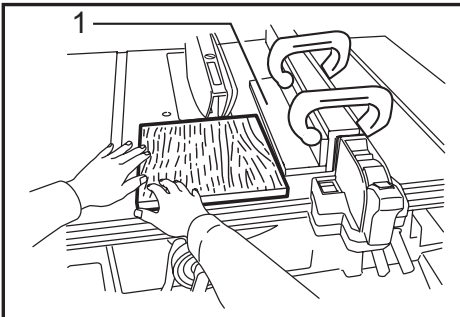

- 1. Auxiliary fence

Feed the workpiece by hand until the end is about 25 mm from the front edge of the table. Continue to feed using the push block on the top of the auxiliary fence until the cut is complete.

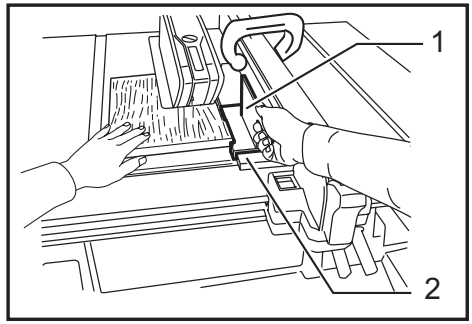

- 1. Push block 2. Auxiliary fence

Cross cutting

⚠ CAUTION:

- When making a crosscut, remove the rip fence from the table.
- When cutting long or large workpieces, always provide adequate support to the sides of the table. The support should be at the same height as the table.
- Always keep hands away from path of blade.

Miter gauge

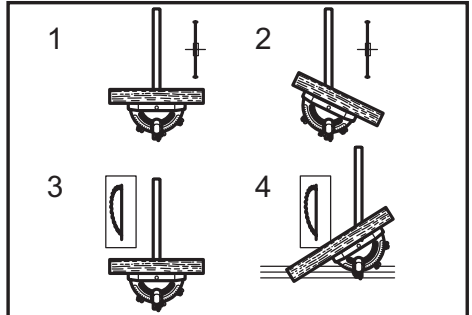

- 1. Cross cutting 2. Mitering 3. Bevel cutting
4. Compound mitering (angles)

Use the miter gauge for the 4 types of cutting shown in the figure.

⚠ CAUTION:

- Secure the knob on the miter gauge carefully.
- Avoid creep of workpiece and gauge by firm workholding arrangement, especially when cutting at an angle.
- NEVER hold or grasp the intended "cut-off" portion of the workpiece.
- Always adjust the distance between the end of the miter gauge and the saw blade not to exceed 15 mm.

Miter gauge positive stop

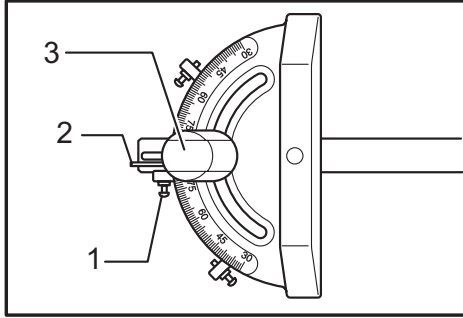

- 1. Knob 2. Small plate 3. Screw for positive stop

Miter gauge is provided with positive stops at 90°, 45° right and left miter angles for quick setting of miter angles.

To set the miter angle, loosen the knob on the miter gauge.

Raise the small plate on the miter gauge for free setting. Turn the miter gauge to the desired miter angle. Return the small plate on the miter gauge to the original position and tighten the knob clockwise securely.

Use of miter gauge

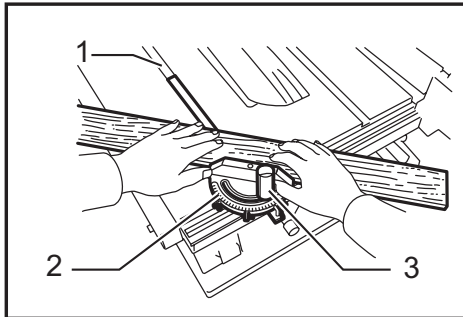

- 1. Groove 2. Miter gauge 3. Knob

Slide the miter gauge into the thick grooves in the table. Loosen the knob on the gauge and align to desired angle (0° to 60°). Bring stock flush up against fence and feed gently forward into the blade.

Auxiliary wood facing (miter gauge)

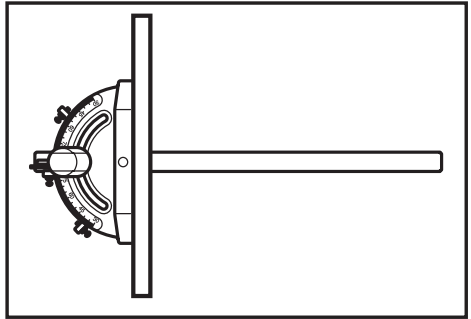

To prevent a long board from wobbling, fit the miter gauge with an auxiliary fence board. Fasten with bolts/nuts after drilling holes, but fasteners must not protrude from the face board.

Carrying tool

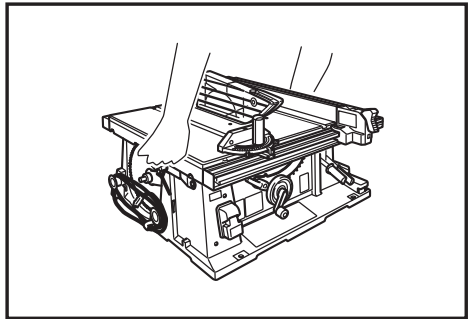

Make sure that the tool is unplugged.

Carry the tool by holding the tool part shown in the figure.

⚠ CAUTION:

- Always secure all moving portions before carrying the tool.
- Always make sure that the blade guard is installed in place before the carrying the tool.

MAINTENANCE

⚠ CAUTION:

- Always be sure that the tool is switched off and unplugged before attempting to perform inspection or maintenance.
- Never use gasoline, benzine, thinner, alcohol or the like. Discoloration, deformation or cracks may result.

Cleaning

Clean out sawdust and chips from time to time.

Carefully clean the blade guard and moving parts inside the table saw.

Lubrication

To keep the table saw in tip-top running condition, and to assure maximum service life, oil or grease the moving parts and rotating parts from time to time.

Lubrication places:

- Threaded shaft to elevate the blade
- Hinge to rotate the frame
- Elevation guide shafts on motor
- Gear to elevate the blade
- Guide rails for the rip fence
- Shaft of the sub table (R) locking levers
- Sliding part of the sub table (R)

Replacing carbon brushes

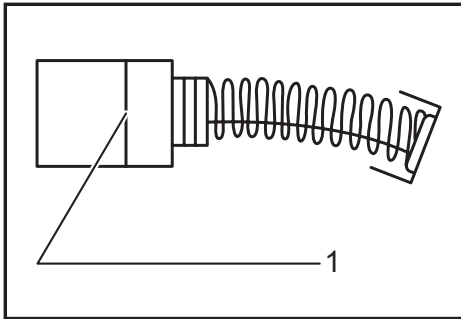

► 1. Limit mark

Remove and check the carbon brushes regularly. Replace when they wear down to the limit mark. Keep the carbon brushes clean and free to slip in the holders. Both carbon brushes should be replaced at the same time. Use only identical carbon brushes. Use a screwdriver to remove the brush holder caps. To replace the carbon brushes, remove the blade guard and blade and then loosen the lock lever, tilt the saw head and secure it at 45° bevel angle. Carefully lay the tool on itself backward. Then loosen the brush holder cap. Remove the worn carbon brushes, insert the new ones and secure the brush holder caps.

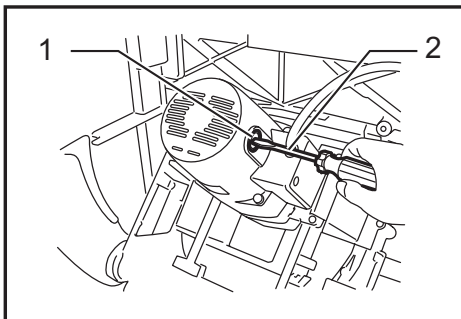

► 1. Brush holder cap 2. Screwdriver

To maintain product SAFETY and RELIABILITY, repairs, any other maintenance or adjustment should be performed by Makita Authorized Service Centers, always using Makita replacement parts.

OPTIONAL ACCESSORIES

⚠ CAUTION:

- These accessories or attachments are recommended for use with your Makita tool specified in this manual. The use of any other accessories or attachments might present a risk of injury to persons. Only use accessory or attachment for its stated purpose.

If you need any assistance for more details regarding these accessories, ask your local Makita Service Center.

Table stand set (accessory)

Refer to the instruction manual for table saw stand that is provided with the table saw stand as an optional accessory.

- Steel & Carbide-tipped saw blades
- Sub table (L)
- Sub table (back)
- Rip fence
- Miter gauge
- Offset wrench 13-22
- Wrench 19
- Hex wrench 5
- Joint (for connecting to dust collector)
- Auxiliary plate
- Stand set
- Sliding guide

NOTE: Some items in the list may be included in the tool package as standard accessories. They may differ from country to country.

Makita Corporation

3-11-8, Sumiyoshi-cho,
Anjo, Aichi 446-8502 Japan

www.makita.com

884599G227 EN 20161213
