

# INSTRUCTION MANUAL

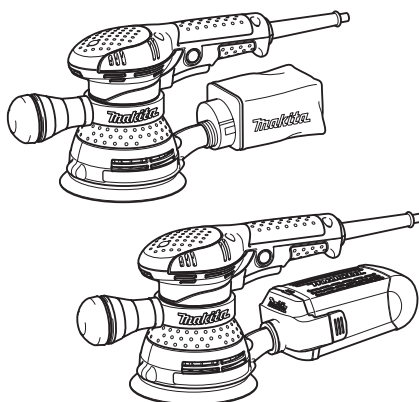

## Random Orbit Sander

**BO5040**  
**BO5041**



DOUBLE INSULATION



Read before use.



# SPECIFICATIONS

Model	BO5040	BO5041
Paper size	125 mm	125 mm
Orbits per minute (min <sup>-1</sup> )	12,000	4,000 - 12,000
Dimensions (L x W x H)	218 mm x 123 mm x 153 mm	218 mm x 123 mm x 153 mm
Net weight	1.4 kg	1.4 kg
Safety class	□/II	□/II

- Due to our continuing program of research and development, the specifications herein are subject to change without notice.
- Specifications may differ from country to country.
- Weight according to EPTA-Procedure 01/2014

## Symbols

The following show the symbols used for the equipment. Be sure that you understand their meaning before use.

	Read instruction manual.
	DOUBLE INSULATION
	Only for EU countries Do not dispose of electric equipment together with household waste material! In observance of the European Directive, on Waste Electric and Electronic Equipment and its implementation in accordance with national law, electric equipment that have reached the end of their life must be collected separately and returned to an environmentally compatible recycling facility.

### Intended use

The tool is intended for the sanding of large surface of wood, plastic and metal materials as well as painted surfaces.

### Power supply

The tool should be connected only to a power supply of the same voltage as indicated on the nameplate, and can only be operated on single-phase AC supply. They are double-insulated and can, therefore, also be used from sockets without earth wire.

### Noise

The typical A-weighted noise level determined according to EN62841:

- Sound pressure level ( $L_{pA}$ ) : 81 dB (A)
- Sound power level ( $L_{WA}$ ) : 92 dB (A)
- Uncertainty (K) : 3 dB (A)

**NOTE:** The declared noise emission value(s) has been measured in accordance with a standard test method and may be used for comparing one tool with another.

**NOTE:** The declared noise emission value(s) may also be used in a preliminary assessment of exposure.

**⚠ WARNING:** Wear ear protection.

**⚠ WARNING:** The noise emission during actual use of the power tool can differ from the declared value(s) depending on the ways in which the tool is used especially what kind of workpiece is processed.

**⚠ WARNING:** Be sure to identify safety measures to protect the operator that are based on an estimation of exposure in the actual conditions of use (taking account of all parts of the operating cycle such as the times when the tool is switched off and when it is running idle in addition to the trigger time).

### Vibration

The vibration total value (tri-axial vector sum) determined according to EN62841:

- Work mode : sanding metal plate
- Vibration emission ( $a_{r1}$ ) : 3.5 m/s<sup>2</sup>
- Uncertainty (K) : 1.5 m/s<sup>2</sup>

**NOTE:** The declared vibration total value(s) has been measured in accordance with a standard test method and may be used for comparing one tool with another.

**NOTE:** The declared vibration total value(s) may also be used in a preliminary assessment of exposure.

**⚠ WARNING:** The vibration emission during actual use of the power tool can differ from the declared value(s) depending on the ways in which the tool is used especially what kind of workpiece is processed.

**⚠ WARNING:** Be sure to identify safety measures to protect the operator that are based on an estimation of exposure in the actual conditions of use (taking account of all parts of the operating cycle such as the times when the tool is switched off and when it is running idle in addition to the trigger time).

## EC Declaration of Conformity

### For European countries only

The EC declaration of conformity is included as Annex A to this instruction manual.

## General power tool safety warnings

**⚠ WARNING:** Read all safety warnings, instructions, illustrations and specifications provided with this power tool. Failure to follow all instructions listed below may result in electric shock, fire and/or serious injury.

### Save all warnings and instructions for future reference.

The term "power tool" in the warnings refers to your mains-operated (corded) power tool or battery-operated (cordless) power tool.

#### Work area safety

1. **Keep work area clean and well lit.** Cluttered or dark areas invite accidents.
2. **Do not operate power tools in explosive atmospheres, such as in the presence of flammable liquids, gases or dust.** Power tools create sparks which may ignite the dust or fumes.
3. **Keep children and bystanders away while operating a power tool.** Distractions can cause you to lose control.

#### Electrical safety

1. **Power tool plugs must match the outlet. Never modify the plug in any way. Do not use any adapter plugs with earthed (grounded) power tools.** Unmodified plugs and matching outlets will reduce risk of electric shock.
2. **Avoid body contact with earthed or grounded surfaces, such as pipes, radiators, ranges and refrigerators.** There is an increased risk of electric shock if your body is earthed or grounded.
3. **Do not expose power tools to rain or wet conditions.** Water entering a power tool will increase the risk of electric shock.
4. **Do not abuse the cord. Never use the cord for carrying, pulling or unplugging the power tool. Keep cord away from heat, oil, sharp edges or moving parts.** Damaged or entangled cords increase the risk of electric shock.
5. **When operating a power tool outdoors, use an extension cord suitable for outdoor use.** Use of a cord suitable for outdoor use reduces the risk of electric shock.
6. **If operating a power tool in a damp location is unavoidable, use a residual current device (RCD) protected supply.** Use of an RCD reduces the risk of electric shock.
7. **Use of power supply via an RCD with a rated residual current of 30 mA or less is always recommended.**
8. **Power tools can produce electromagnetic fields (EMF) that are not harmful to the user.** However, users of pacemakers and other similar medical devices should contact the maker of their device and/or doctor for advice before operating this power tool.
9. **Do not touch the power plug with wet hands.**
10. **If the cord is damaged, have it replaced by the manufacturer or his agent in order to avoid a safety hazard.**

#### Personal safety

1. **Stay alert, watch what you are doing and use common sense when operating a power tool. Do not use a power tool while you are tired or under the influence of drugs, alcohol or medication.** A moment of inattention while operating power tools may result in serious personal injury.
2. **Use personal protective equipment. Always wear eye protection.** Protective equipment such as a dust mask, non-skid safety shoes, hard hat or hearing protection used for appropriate conditions will reduce personal injuries.
3. **Prevent unintentional starting. Ensure the switch is in the off-position before connecting to power source and/or battery pack, picking up or carrying the tool.** Carrying power tools with your finger on the switch or energising power tools that have the switch on invites accidents.
4. **Remove any adjusting key or wrench before turning the power tool on.** A wrench or a key left attached to a rotating part of the power tool may result in personal injury.
5. **Do not overreach. Keep proper footing and balance at all times.** This enables better control of the power tool in unexpected situations.
6. **Dress properly. Do not wear loose clothing or jewellery. Keep your hair and clothing away from moving parts.** Loose clothes, jewellery or long hair can be caught in moving parts.
7. **If devices are provided for the connection of dust extraction and collection facilities, ensure these are connected and properly used.** Use of dust collection can reduce dust-related hazards.
8. **Do not let familiarity gained from frequent use of tools allow you to become complacent and ignore tool safety principles.** A careless action can cause severe injury within a fraction of a second.
9. **Always wear protective goggles to protect your eyes from injury when using power tools. The goggles must comply with ANSI Z87.1 in the USA, EN 166 in Europe, or AS/NZS 1336 in Australia/New Zealand. In Australia/New Zealand, it is legally required to wear a face shield to protect your face, too.**

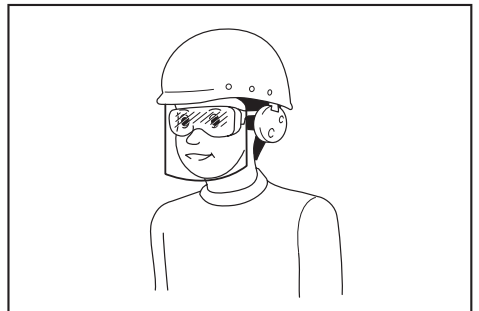

It is an employer's responsibility to enforce the use of appropriate safety protective equipments by the tool operators and by other persons in the immediate working area.

### Power tool use and care

1. **Do not force the power tool. Use the correct power tool for your application.** The correct power tool will do the job better and safer at the rate for which it was designed.
2. **Do not use the power tool if the switch does not turn it on and off.** Any power tool that cannot be controlled with the switch is dangerous and must be repaired.
3. **Disconnect the plug from the power source and/or remove the battery pack, if detachable, from the power tool before making any adjustments, changing accessories, or storing power tools.** Such preventive safety measures reduce the risk of starting the power tool accidentally.
4. **Store idle power tools out of the reach of children and do not allow persons unfamiliar with the power tool or these instructions to operate the power tool.** Power tools are dangerous in the hands of untrained users.
5. **Maintain power tools and accessories. Check for misalignment or binding of moving parts, breakage of parts and any other condition that may affect the power tool's operation. If damaged, have the power tool repaired before use.** Many accidents are caused by poorly maintained power tools.
6. **Keep cutting tools sharp and clean.** Properly maintained cutting tools with sharp cutting edges are less likely to bind and are easier to control.
7. **Use the power tool, accessories and tool bits etc. in accordance with these instructions, taking into account the working conditions and the work to be performed.** Use of the power tool for operations different from those intended could result in a hazardous situation.
8. **Keep handles and grasping surfaces dry, clean and free from oil and grease.** Slippery handles and grasping surfaces do not allow for safe handling and control of the tool in unexpected situations.
9. **When using the tool, do not wear cloth work gloves which may be entangled.** The entanglement of cloth work gloves in the moving parts may result in personal injury.

### Service

1. **Have your power tool serviced by a qualified repair person using only identical replacement parts.** This will ensure that the safety of the power tool is maintained.
2. **Follow instruction for lubricating and changing accessories.**

## SANDER SAFETY WARNINGS

1. **Always use safety glasses or goggles. Ordinary eye or sun glasses are NOT safety glasses.**
2. **Hold the tool firmly.**
3. **Do not leave the tool running. Operate the tool only when hand-held.**
4. **This tool has not been waterproofed, so do not use water on the workpiece surface.**
5. **Ventilate your work area adequately when you perform sanding operations.**
6. **Some material contains chemicals which may be toxic. Take caution to prevent dust inhalation and skin contact. Follow material supplier safety data.**

7. **Use of this tool to sand some products, paints and wood could expose user to dust containing hazardous substances. Use appropriate respiratory protection.**
8. **Be sure that there are no cracks or breakage on the pad before use. Cracks or breakage may cause a personal injury.**

## SAVE THESE INSTRUCTIONS.

**⚠WARNING:** DO NOT let comfort or familiarity with product (gained from repeated use) replace strict adherence to safety rules for the subject product. MISUSE or failure to follow the safety rules stated in this instruction manual may cause serious personal injury.

## FUNCTIONAL DESCRIPTION

### ⚠CAUTION:

- Always be sure that the tool is switched off and unplugged before adjusting or checking function on the tool.

### Switch action

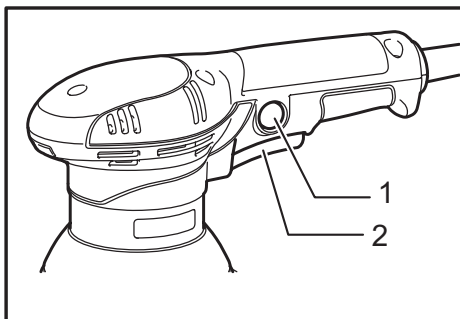

- 1. Lock button 2. Switch trigger

### ⚠CAUTION:

- Before plugging in the tool, always check to see that the switch trigger actuates properly and returns to the "OFF" position when released.
- Switch can be locked in "ON" position for ease of operator comfort during extended use. Apply caution when locking tool in "ON" position and maintain firm grasp on tool.

To start the tool, simply pull the switch trigger. Release the switch trigger to stop.

For continuous operation, pull the switch trigger and push in the lock button and then release the switch trigger.

To stop the tool from the locked position, pull the switch trigger fully, then release it.

## Speed adjusting dial

For Model BO5041

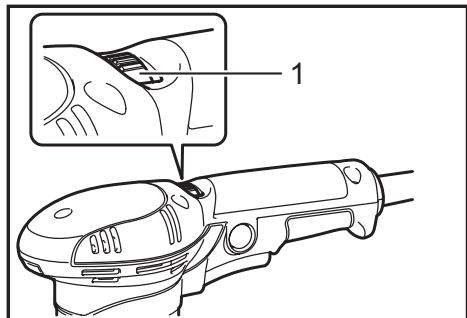

► 1. Speed adjusting dial

The tool speed can be infinitely adjusted between 4,000 and 12,000 orbit per minute by turning the adjusting dial. Higher speed is obtained when the dial is turned in the direction of number 5; lower speed is obtained when it is turned in the direction of number 1.

Refer to the figure for the relationship between the number settings on the adjusting dial and the kind of work.

A range: For polishing

B range: For finish sanding

C range: For regular sanding

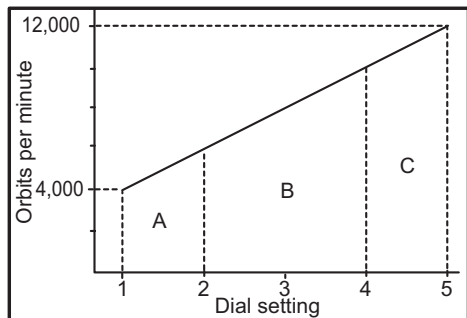

### NOTE:

- The figure shows standard applications. They may differ under certain conditions.

## ASSEMBLY

### CAUTION:

- Always be sure that the tool is switched off and unplugged before carrying out any work on the tool.

## How to use the front grip

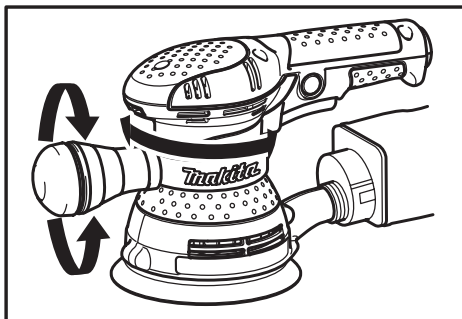

The front grip can be loosened and moved horizontally to a desired working position. Once the front grip is in the desired position, retighten before using.

## Installing or removing the front grip

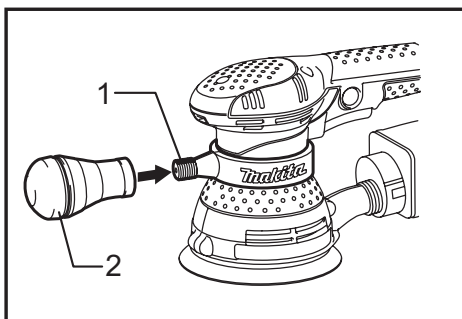

► 1. Screw 2. Front grip

Open the grip base, and attach it to the sander in the area of the Makita logo.

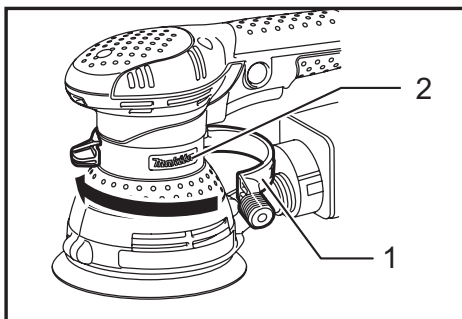

► 1. Grip base 2. Makita logo

After closing the grip base, firmly tighten on the front grip to the screw section of the grip base.

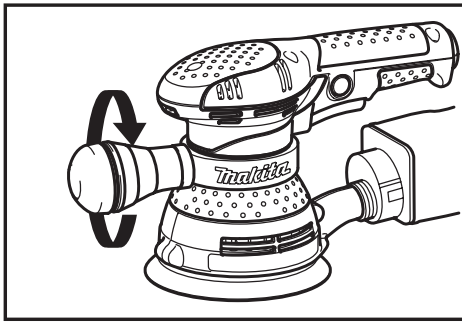

To remove, loosen and remove front grip, and then remove grip base.

## Installing or removing abrasive disc

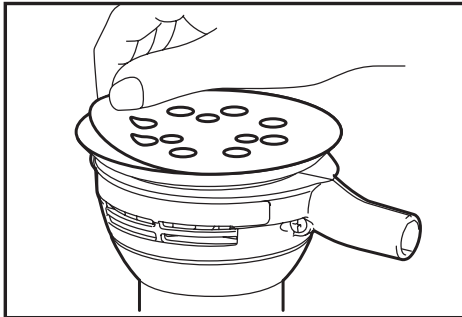

To install the abrasive disc, first remove all dirt or foreign matter from the pad. Then peel off the backing paper from the abrasive disc and attach the abrasive disc to the pad. Be careful to align the holes in the abrasive disc with those in the pad.

### CAUTION:

- If you peel off the abrasive disc from the pad, its adhesion will become poor. Never attempt to stick it onto the pad for further use.

## Installing dust bag

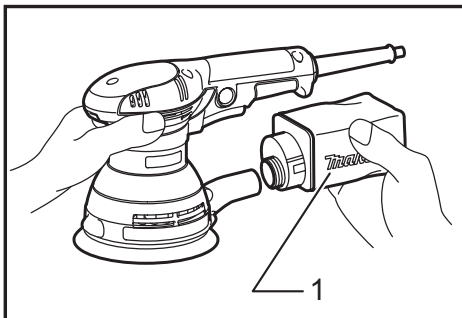

► 1. Dust bag

Install the dust bag on the tool so that the Makita logo on the dust bag will be upright (not upside down).

## Emptying dust bag

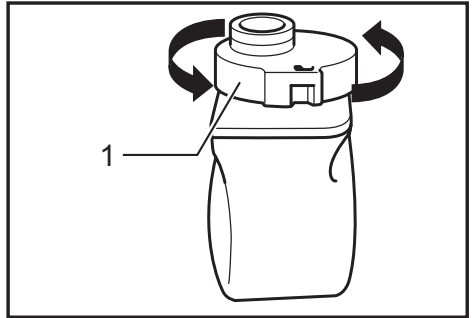

► 1. Dust nozzle

When the dust bag is about half full, switch off and unplug the tool. Remove the dust bag from the tool. Then remove the dust nozzle from the dust bag after unlocking the dust nozzle by turning it slightly counterclockwise. Empty the dust bag by tapping it lightly.

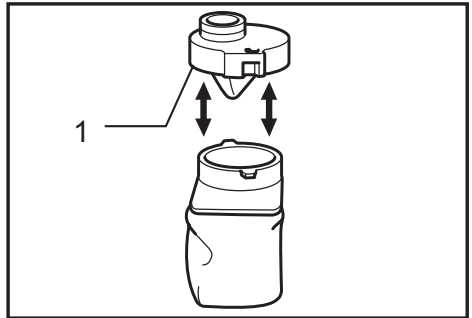

► 1. Dust nozzle

After emptying the dust bag, install the dust nozzle on the dust bag. Turn the dust nozzle slightly clockwise to lock it in place. Then install the dust bag on the tool as described in "Installing dust bag".

## Installing paper dust bag

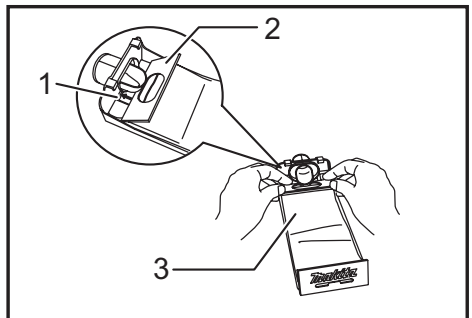

► 1. Groove 2. Front fixing cardboard 3. Front side of paper dust bag

Place the paper dust bag on the paper dust bag holder with its front side upward. Insert the front fixing cardboard of the paper dust bag into the groove of the paper dust bag holder.

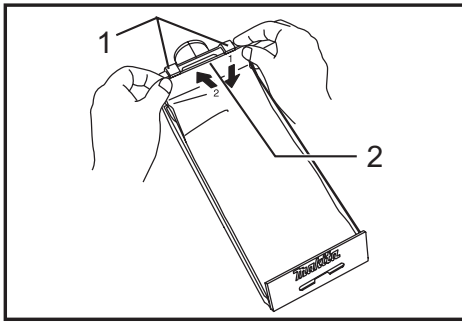

► 1. Claws 2. Upper part

Then press the upper part of the front fixing cardboard in arrow direction to hook it onto the claws.

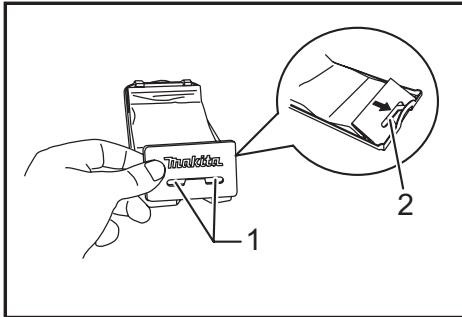

► 1. Notch 2. Guide

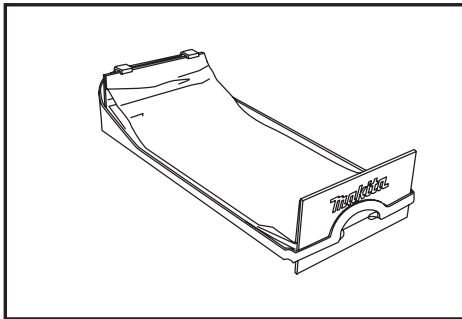

Insert the notch of the paper dust bag into the guide of the paper dust bag holder. Then install the paper dust bag holder set on the tool.

## Installing paper filter bag

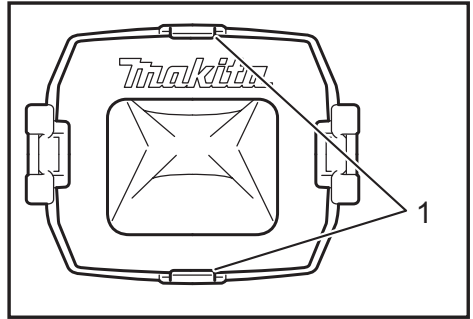

► 1. Holding tab

Make sure that the logo on the cardboard lip and the logo on the dust box are on the same side, then install the paper filter bag by fitting the cardboard lip in the groove of each holding tab.

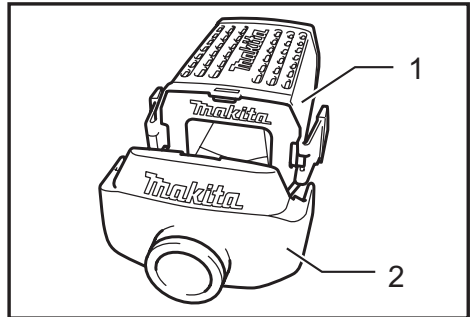

► 1. Dust box 2. Dust nozzle

Make sure that the logo on the cardboard lip and the logo on the dust nozzle are on the same side, then install the dust nozzle on the dust box.

## Removing dust box and paper filter bag

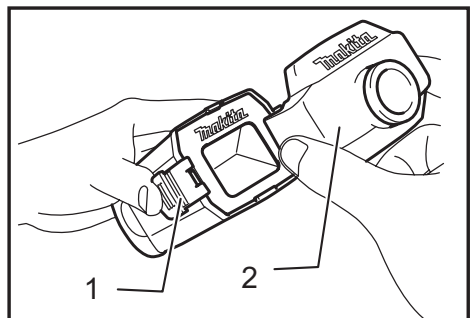

► 1. Latch 2. Dust nozzle

Remove the dust nozzle by pushing the two latches.

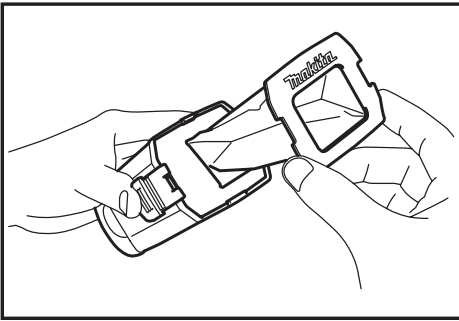

Remove the paper filter bag first by pinching the logo side of its cardboard lip, then by pulling the cardboard lip downwards to move it out of the holding tab of the dust box.

## OPERATION

### ⚠ CAUTION:

- Always use the front grip and firmly hold the tool by front grip and switch handle during operations.

## Sanding operation

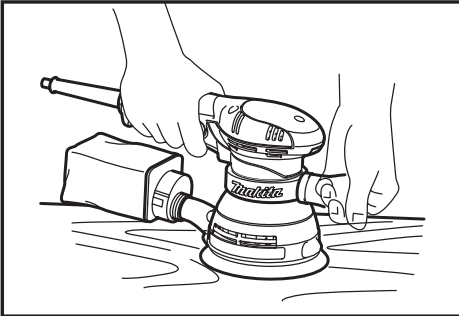

### ⚠ CAUTION:

- Never run the tool without the abrasive disc. You may seriously damage the pad.
- Never force the tool. Excessive pressure may decrease the sanding efficiency, damage the abrasive disc or shorten tool life.
- Using the tool with the pad edge contacting the workpiece may damage the pad.

Hold the tool firmly. Turn the tool on and wait until it attains full speed. Then gently place the tool on the workpiece surface. Keep the pad flush with the workpiece and apply slight pressure on the tool.

### ⚠ CAUTION:

- The sanding pad rotates clockwise during the loaded operation, but it may rotate counterclockwise during the no-load operation.

## Polishing operation

For Model BO5041

### ⚠ CAUTION:

- Use only a Makita genuine sponge pad, felt pad or wool pad (optional accessories).
- Always operate the tool at low speed to prevent work surfaces from heating abnormally.
- Never force the tool. Excessive pressure may decrease the polishing efficiency and cause motor overload, resulting in tool malfunction.

## 1. Applying wax

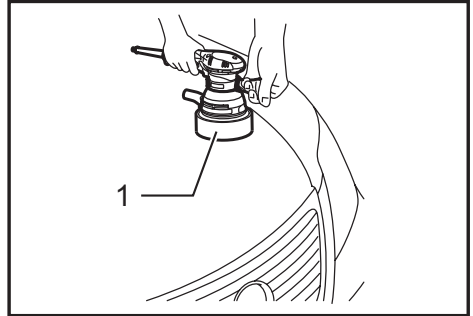

### ► 1. Sponge pad

Use an optional sponge pad. Apply wax to the sponge pad or work surface. Run the tool at low speed to smooth out wax.

### NOTE:

- First, wax a not conspicuous portion of the work surface to make sure that the tool will not scratch the surface or result in uneven waxing.
- Always run the tool at low speed. Running it at high speed may cause the wax to spatter.

## 2. Removing wax

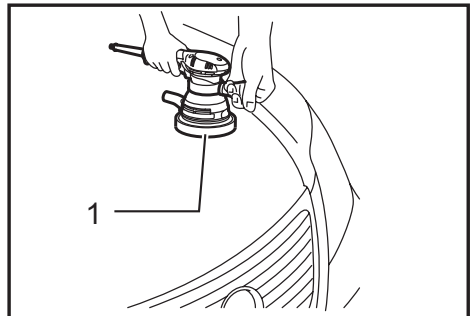

### ► 1. Felt pad

Use an optional felt pad. Run the tool at low speed to remove wax.



### 3. Polishing

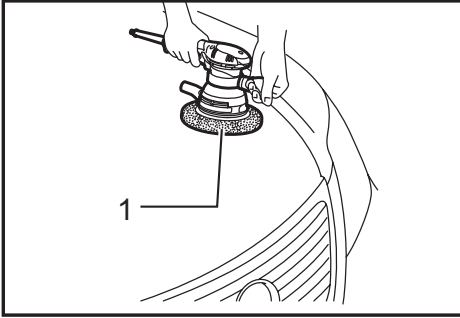

► 1. Wool bonnet

Use an optional wool pad. Run the tool at low speed and apply the wool pad gently to the work surface.

**NOTE:**

- Some items in the list may be included in the tool package as standard accessories. They may differ from country to country.

## MAINTENANCE

**⚠ CAUTION:**

- Always be sure that the tool is switched off and unplugged before attempting to perform inspection or maintenance.
- Never use gasoline, benzine, thinner, alcohol or the like. Discoloration, deformation or cracks may result.

To maintain product SAFETY and RELIABILITY, repairs, carbon brush inspection and replacement, any other maintenance or adjustment should be performed by Makita Authorized Service Centers, always using Makita replacement parts.

## OPTIONAL ACCESSORIES

**⚠ CAUTION:**

- These accessories or attachments are recommended for use with your Makita tool specified in this manual. The use of any other accessories or attachments might present a risk of injury to persons. Only use accessory or attachment for its stated purpose.

If you need any assistance for more details regarding these accessories, ask your local Makita Service Center.

- Hook-and-loop type abrasive discs (with pre-punched holes)
- Hook-and-loop type sponge pad
- Paper dust bag holder  
(For BO5041 only)
- Hook-and-loop type felt pad
- Hook-and-loop type wool pad
- Paper dust bag





**Makita Europe N.V.** Jan-Baptist Vinkstraat 2,  
3070 Kortenberg, Belgium

**Makita Corporation** 3-11-8, Sumiyoshi-cho,  
Anjo, Aichi 446-8502 Japan

[www.makita.com](http://www.makita.com)

884946C222 EN 20190517
------------------------------