

INSTRUCTION MANUAL

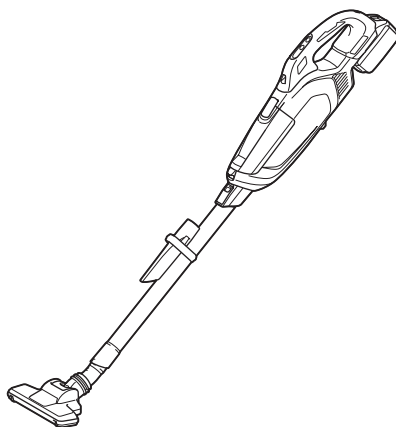

Cordless Cleaner

DCL285F



Read before use.

WARNING

- This appliance can be used by children aged from 8 years and above and persons with reduced physical, sensory or mental capabilities or lack of experience and knowledge if they have been given supervision or instruction concerning use of the appliance in a safe way and understand the hazards involved.
- Children shall not play with the appliance. Cleaning and user maintenance shall not be made by children without supervision.
- See the chapter "SPECIFICATIONS" for the type reference of the battery.
- See the section "Installing or removing battery cartridge" for how to remove or install the battery.
- When disposing the battery cartridge, remove it from the tool and dispose of it in a safe place. Follow your local regulations relating to disposal of battery.
- If the tool is not used for a long period of time, the battery must be removed from the tool.
- Do not short the battery cartridge.
- See the chapter "MAINTENANCE" for the appropriate details of precautions during user maintenance.

SPECIFICATIONS

Model:		DCL285F
Capacity	with dust bag	500 mL
	with paper filter	330 mL
Continuous use (with battery BL1830B)	1 (Quiet mode)	Approx. 38 min
	2 (Normal speed mode)	Approx. 21 min
	3 (High speed mode)	Approx. 15 min
	4 (Max speed mode)	Approx. 8 min
Overall length (with pipe, nozzle, and battery BL1830B)		1,066 mm
Rated voltage		D.C. 18 V
Net weight		1.4 - 1.7 kg

- Due to our continuing program of research and development, the specifications herein are subject to change without notice.
- Specifications may differ from country to country.
- The weight does not include accessories but battery cartridge(s). The lightest and heaviest combination weight of the appliance and battery cartridge(s) are shown in the table.

Applicable battery cartridge and charger



Battery cartridge	BL1815N / BL1820B / BL1830B / BL1840B / BL1850B / BL1860B
Charger	DC18RC / DC18RD / DC18RE / DC18SD / DC18SE / DC18SF / DC18SH / DC18WC

- Some of the battery cartridges and chargers listed above may not be available depending on your region of residence.

⚠ WARNING: Only use the battery cartridges and chargers listed above. Use of any other battery cartridges and chargers may cause injury and/or fire.

Symbols

The followings show the symbols which may be used for the equipment. Be sure that you understand their meaning before use.

	Read the instruction manual.
	A representative battery applicable to this product.



Ni-MH
Li-ion

Only for EU countries
Due to the presence of hazardous components in the equipment, waste electrical and electronic equipment, accumulators and batteries may have a negative impact on the environment and human health. Do not dispose of electrical and electronic appliances or batteries with household waste! In accordance with the European Directive on waste electrical and electronic equipment and on accumulators and batteries and waste accumulators and batteries, as well as their adaptation to national law, waste electrical equipment, batteries and accumulators should be stored separately and delivered to a separate collection point for municipal waste, operating in accordance with the regulations on environmental protection. This is indicated by the symbol of the crossed-out wheeled bin placed on the equipment.

Intended use

The tool is intended for collecting dry dust.

SAFETY WARNINGS

Cordless cleaner safety warnings

⚠ WARNING: IMPORTANT! READ CAREFULLY all safety warnings and all instructions BEFORE USE. Failure to follow the warnings and instructions may result in electric shock, fire and/or serious injury.

1. Do not expose to rain. Store indoors.
2. Do not allow to be used as a toy. Close attention is necessary when used by or near children.
3. Use only as described in this manual. Use only manufacturer's recommended attachments.
4. Do not use with damaged battery. If appliance is not working as it should, has been dropped, damaged, left outdoors, or dropped into water, return it to a service center.
5. Do not handle appliance with wet hands.
6. Do not put any object into openings. Do not use with any opening blocked; keep free of dust, lint, hair, and anything that may reduce air flow.
7. Keep hair, loose clothing, fingers, and all parts of body away from openings and moving parts.
8. Turn off all controls before removing the battery.
9. Use extra care when cleaning on stairs.
10. Do not use to pick up flammable or combustible liquids, such as gasoline, or use in areas where they may be present.
11. Use only the charger supplied by the manufacturer to recharge.
12. Do not pick up anything that is burning or smoking, such as cigarettes, matches, or hot ashes.
13. Do not use without dust bag and/or filters in place.
14. Do not charge the battery outdoors.
15. Recharge only with the charger specified by the manufacturer. A charger that is suitable for one type of battery pack may create a risk of fire when used with another battery pack.
16. Use appliances only with specifically designated battery packs. Use of any other battery packs may create a risk of injury and fire.
17. When (the) battery pack is not in use, keep it away from other metal objects, like paper clips, coins, keys, nails, screws or other small metal objects, that can make a connection from one terminal to another.
18. Under abusive conditions, liquid may be ejected from the battery; avoid contact. If contact accidentally occurs, flush with water.

19. Do not use a battery pack or appliance that is damaged or modified. Damaged or modified batteries may exhibit unpredictable behaviour resulting in fire, explosion or risk of injury.
20. Do not expose a battery pack or appliance to fire or excessive temperature. Exposure to fire or temperature above 130 °C may cause explosion.
21. Follow all charging instructions and do not charge the battery pack or appliance outside the temperature range specified in the instructions. Charging improperly or at temperatures outside the specified range may damage the battery and increase the risk of fire.

SAVE THESE INSTRUCTIONS.

ADDITIONAL SAFETY RULES

This appliance is intended for household use.

1. Read this instruction manual and the charger instruction manual carefully before use.
2. Do not pick up the following materials:
 - Hot substances that are burning or smoking (cigarettes, matches, incense sticks, candles, hot ashes), sparks and metal dust generated by cutting or grinding metal, etc.
 - Flammable liquid (kerosene, gasoline, solvents such as benzene, thinner, etc.)
 - Flammable material (toner, paint, spray, etc.)
 - Explosive or pyrophoric substances (nitroglycerin, aluminum, magnesium, titanium, zinc, red phosphorus, yellow phosphorus, celluloid, etc. and their dust, gas or steam)
 - Liquid, oil, wet dirt or damp garbage, including vomit and excreta
 - Hard pieces with sharp edges (wood chips, metals, stones, glasses, nails, pins, razors or cutlery)
 - Solidifying and conductive fine powder (metal or carbon powder)
 - Foam like carpet cleaning agent, etc. (they may cause explosion or fire)
 - Large amount of powder (flour, fire extinguisher powder, etc.)
 - Substances that cause toxic symptoms
 - Aggressive chemicals (acid, alkali, etc.)
 - Fine binding powder such as cement
 - Fine particle like concrete dust
 - Desiccants
 - Asbestos
 - PesticidesSuch action may cause fire, injury and/or property damage.
To reduce your exposure to these chemicals, always wear approved respiratory protection such as dust masks that are specially designed to filter out microscopic particles. Direct the exhaust air away from your face and body.
3. Stop operation immediately if you notice anything abnormal.

4. If you drop or strike the cleaner, check it carefully for cracks or damage before operation.
5. Do not bring close to stoves or other heat sources.
6. Do not block the intake hole or vent holes.

SAVE THESE INSTRUCTIONS.

Important safety instructions for battery cartridge

1. Before using battery cartridge, read all instructions and cautionary markings on (1) battery charger, (2) battery, and (3) product using battery.
2. Do not disassemble or tamper with the battery cartridge. It may result in a fire, excessive heat, or explosion.
3. If operating time has become excessively shorter, stop operating immediately. It may result in a risk of overheating, possible burns and even an explosion.
4. If electrolyte gets into your eyes, rinse them out with clear water and seek medical attention right away. It may result in loss of your eyesight.
5. Do not short the battery cartridge:
 - (1) Do not touch the terminals with any conductive material.
 - (2) Avoid storing battery cartridge in a container with other metal objects such as nails, coins, etc.
 - (3) Do not expose battery cartridge to water or rain.

A battery short can cause a large current flow, overheating, possible burns and even a breakdown.

6. Do not store and use the tool and battery cartridge in locations where the temperature may reach or exceed 50 °C (122 °F).
7. Do not incinerate the battery cartridge even if it is severely damaged or is completely worn out. The battery cartridge can explode in a fire.
8. Do not nail, cut, crush, throw, drop the battery cartridge, or hit against a hard object to the battery cartridge. Such conduct may result in a fire, excessive heat, or explosion.
9. Do not use a damaged battery.
10. The contained lithium-ion batteries are subject to the Dangerous Goods Legislation requirements.

For commercial transports e.g. by third parties, forwarding agents, special requirement on packaging and labeling must be observed. For preparation of the item being shipped, consulting an expert for hazardous material is required. Please also observe possibly more detailed national regulations.

Tape or mask off open contacts and pack up the battery in such a manner that it cannot move around in the packaging.

11. When disposing the battery cartridge, remove it from the tool and dispose of it in a safe place. Follow your local regulations relating to disposal of battery.
12. Use the batteries only with the products specified by Makita. Installing the batteries to non-compliant products may result in a fire, excessive heat, explosion, or leak of electrolyte.
13. If the tool is not used for a long period of time, the battery must be removed from the tool.
14. During and after use, the battery cartridge may take on heat which can cause burns or low temperature burns. Pay attention to the handling of hot battery cartridges.
15. Do not touch the terminal of the tool immediately after use as it may get hot enough to cause burns.
16. Do not allow chips, dust, or soil stuck into the terminals, holes, and grooves of the battery cartridge. It may cause heating, catching fire, burst and malfunction of the tool or battery cartridge, resulting in burns or personal injury.
17. Unless the tool supports the use near high-voltage electrical power lines, do not use the battery cartridge near high-voltage electrical power lines. It may result in a malfunction or breakdown of the tool or battery cartridge.
18. Keep the battery away from children.

SAVE THESE INSTRUCTIONS.

⚠ CAUTION: Only use genuine Makita batteries. Use of non-genuine Makita batteries, or batteries that have been altered, may result in the battery bursting causing fires, personal injury and damage. It will also void the Makita warranty for the Makita tool and charger.

Tips for maintaining maximum battery life

1. Charge the battery cartridge before completely discharged. Always stop tool operation and charge the battery cartridge when you notice less tool power.
2. Never recharge a fully charged battery cartridge. Overcharging shortens the battery service life.
3. Charge the battery cartridge with room temperature at 10 °C - 40 °C (50 °F - 104 °F). Let a hot battery cartridge cool down before charging it.
4. When not using the battery cartridge, remove it from the tool or the charger.
5. Charge the battery cartridge if you do not use it for a long period (more than six months).

FUNCTIONAL DESCRIPTION

CAUTION: Always be sure that the tool is switched off and the battery cartridge is removed before adjusting or checking function on the tool.

CAUTION: Take care not to trap finger(s) between cleaner and battery as shown in diagram when loading battery. Trapping finger(s) may cause injury.

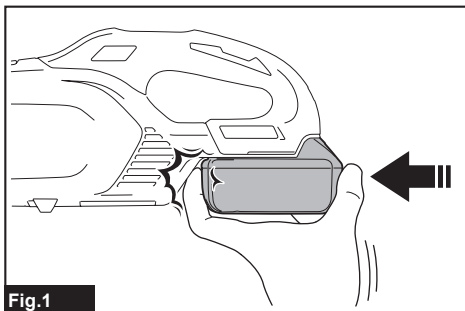

Fig.1

Installing or removing battery cartridge

CAUTION: Always switch off the tool before installing or removing of the battery cartridge.

CAUTION: Hold the tool and the battery cartridge firmly when installing or removing battery cartridge. Failure to hold the tool and the battery cartridge firmly may cause them to slip off your hands and result in damage to the tool and battery cartridge and a personal injury.

To remove the battery cartridge, slide it from the tool while sliding the button on the front of the cartridge.

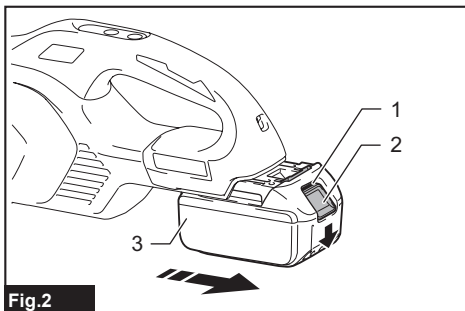

Fig.2

► 1. Red indicator 2. Button 3. Battery cartridge

To install the battery cartridge, align the tongue on the battery cartridge with the groove in the housing and slip it into place. Insert it all the way until it locks in place with a little click. If you can see the red indicator as shown in the figure, it is not locked completely.

CAUTION: Always install the battery cartridge fully until the red indicator cannot be seen. If not, it may accidentally fall out of the tool, causing injury to you or someone around you.

CAUTION: Do not install the battery cartridge forcibly. If the cartridge does not slide in easily, it is not being inserted correctly.

Tool / battery protection system

The tool is equipped with tool/battery protection system. This system automatically cuts off power to the motor to extend tool and battery life. The tool will automatically stop during operation if the tool or battery is placed under one of the following conditions.

Overloaded:

The tool/battery is operated in a manner that causes it to draw an abnormally high current. In this situation, turn the tool off and stop the application that caused the tool to become overloaded. Then turn the tool on to restart.

Overheated:

The tool/battery is overheated. In this situation, let the tool/battery cool before turning the tool on again.

Low battery voltage:

The remaining battery capacity is too low and the tool will not operate. In this situation, remove and recharge the battery.

Protections against other causes:

Protection system is also designed for other causes that could damage the tool and allows the tool to stop automatically. Take all the following steps to clear the causes, when the tool has been brought to a temporary halt or stop in operation.

1. Turn the tool off, and then turn it on again to restart.
2. Charge the battery(ies) or replace it/them with recharged battery(ies).
3. Let the tool and battery(ies) cool down.

If no improvement can be found by restoring protection system, then contact your local Makita Service Center.

Indicating the remaining battery capacity

Only for battery cartridges with the indicator

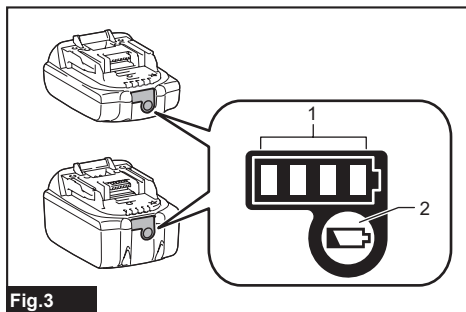

Fig.3

► 1. Indicator lamps 2. Check button

Press the check button on the battery cartridge to indicate the remaining battery capacity. The indicator lamps light up for a few seconds.

Indicator lamps			Remaining capacity
Lighted	Off	Blinking	
■	□	▧	75% to 100%
■ ■ ■ ■			
■ ■ ■	□		50% to 75%
■ ■	□ □		25% to 50%
■	□ □ □		0% to 25%
▧	□ □ □		Charge the battery.
■ ■ □ □			The battery may have malfunctioned.
□ □ ■ ■	↑ ↓		

NOTE: Depending on the conditions of use and the ambient temperature, the indication may differ slightly from the actual capacity.

NOTE: The first (far left) indicator lamp will blink when the battery protection system works.

Switch action

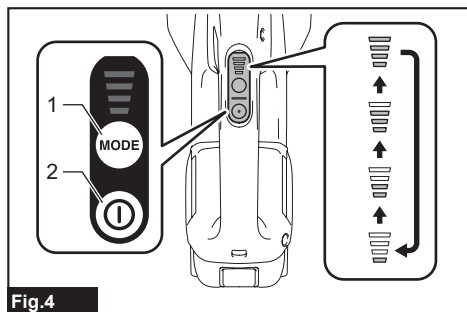

Fig.4

- 1. Suction power change button 2. ON/OFF button

To start the cleaner, simply push the ON/OFF button. To switch off, push the ON/OFF button again. You can change the suction power of the cleaner in four steps by pushing the suction power change button. Each push on this button repeats the Quiet/Normal/High/Max mode in a cycle.

Level	Indication	Mode
1	▮▮▮▮	Quiet mode
2	▮▮▮▮▮▮	Normal speed mode
3	▮▮▮▮▮▮▮▮	High speed mode
4	▮▮▮▮▮▮▮▮▮▮	Max speed mode

NOTE: You can change the suction power before turning on the cleaner.

NOTE: The cleaner starts the operation with the same suction power as the last operation.

Lighting up the lamp

CAUTION: Do not look in the light or see the source of light directly.

To turn on the lamp, push the suction power change button. The lamp goes off in approximately 10 seconds. While the cleaner is running, the lamp turns on. The lamp goes out approximately 10 seconds after stopping operation.

NOTE: When the remaining battery capacity gets low, the lamp starts blinking. The timing, at which the lamp starts blinking depends on the temperature at work place and the battery cartridge conditions.

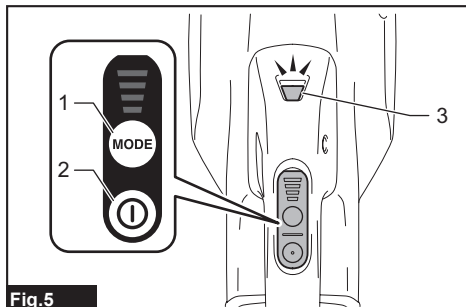

Fig.5

- 1. Suction power change button 2. ON/OFF button
3. Lamp

ASSEMBLY

CAUTION: Always be sure that the tool is switched off and the battery cartridge is removed before carrying out any work on the tool.

Dust bag and paper filter

Install either dust bag or paper filter before using cleaner.

Use the dust stopper when installing either dust bag or paper filter.

Dust bag are usable many times repeatedly by cleaning it out.

Paper filter is a throw-away type. Throw away the entire paper filter without emptying when it has become full.

NOTICE: To prevent dust from getting into the motor:

- Make sure that the dust bag or paper filter is installed before use.
- Insert the dust stopper together with the dust bag or paper filter all the way into the slots when installing them.
- Do not use a broken or ripped bag.

Otherwise the motor may be broken.

NOTICE: Do not fold the cardboard at its opening when installing the paper filter.

NOTICE: Never throw away the dust stopper because it needs to be used repeatedly whenever either the dust bag or the paper filter is used.

NOTICE: The paper filter for the cleaner is an important component for maintaining the tool performance. Using other than the genuine paper filter may cause smokes or ignition.

NOTE: When the dust bag or the paper filter is not installed in the cleaner, the front cover does not close completely.

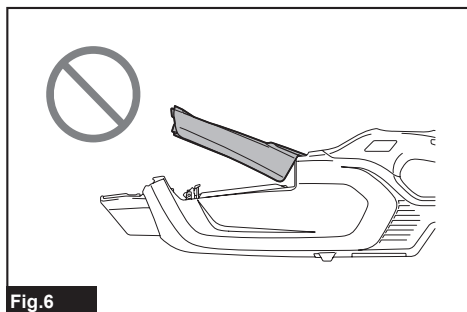

Fig.6

Installing dust bag

Use the dust stopper when installing dust bag. Be careful not to take the upper side for the lower side by mistake because they are different each other.

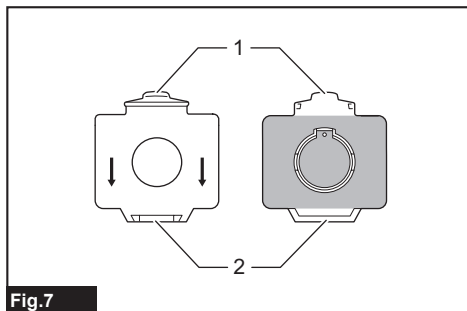

Fig.7

- 1. Upper side of dust stopper 2. Lower side of dust stopper

1. Insert the protrusion of the dust bag into the lower groove on the dust stopper as shown in the figure.

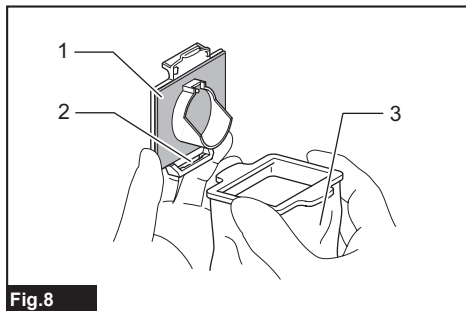

Fig.8

- 1. Dust stopper 2. Lower groove 3. Dust bag

There is no distinction between the upper and lower sides of the dust bag. You may insert its protrusion of either side into the lower groove of the dust stopper.

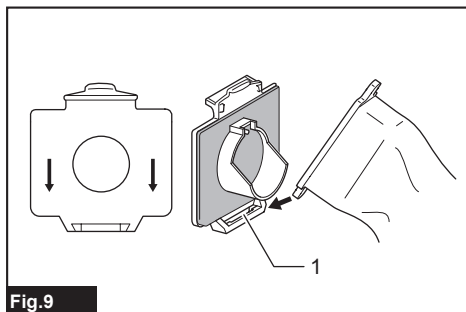

Fig.9

- 1. Lower groove

2. Overlap the frame of dust stopper with that of the dust bag.

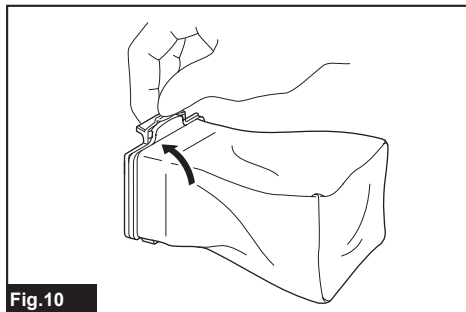

Fig.10

- Place the dust stopper and the dust bag together into the cleaner cavity in the same direction of arrow on the dust stopper. Insert them all the way into the slots in the cleaner cavity.

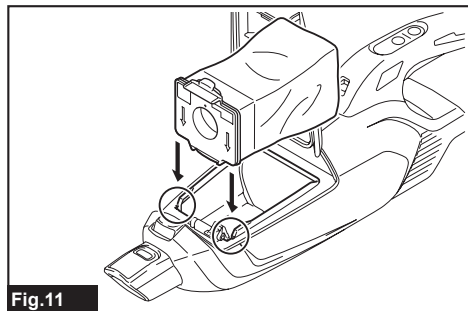

Fig.11

- Spread the cloth part of the dust bag inside the cleaner.

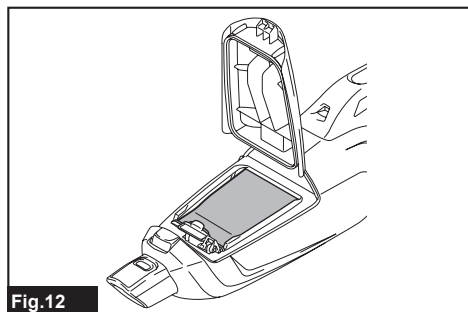

Fig.12

- Close the front cover completely.

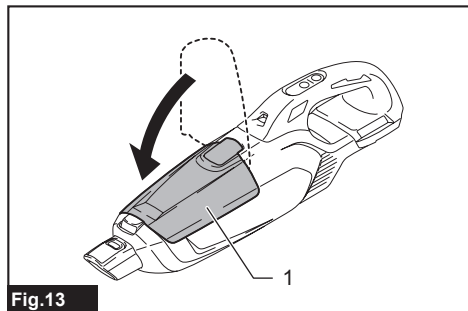

Fig.13

- Front cover

Installing the paper filter

Use the dust stopper also when installing paper filter. Be careful not to take the upper side for the lower side by mistake because they are different each other.

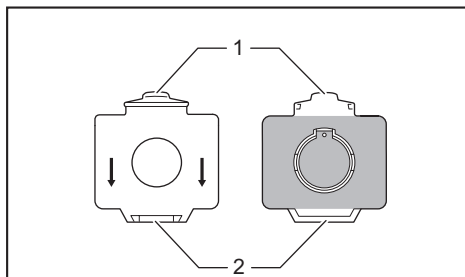

Fig.14

- Upper side of dust stopper 2. Lower side of dust stopper

- Unfold the entrance of the paper filter before setting it on the dust stopper.

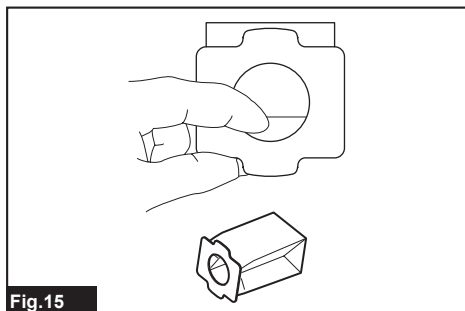

Fig.15

- Insert the protrusion of the paper filter into the lower groove on the dust stopper as shown in the figure.

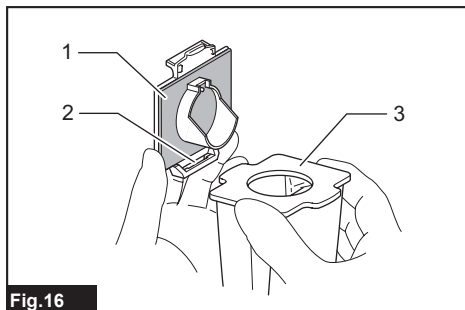

Fig.16

- Dust stopper 2. Lower groove 3. Paper filter

There is no distinction between the upper and lower sides of the paper filter. You may insert its protrusion of any side into the lower groove of the dust stopper.

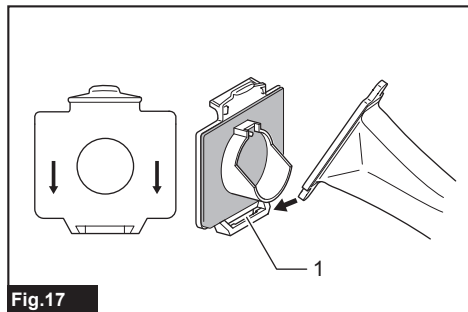

Fig.17

► 1. Lower groove

3. Overlap the frame of dust stopper with that of the paper filter.

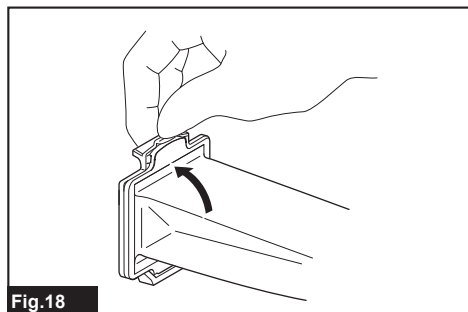

Fig.18

4. Place the dust stopper and the paper filter together into the cleaner cavity in the same direction of arrow on the dust stopper. Insert them all the way into the slots in the cleaner cavity.

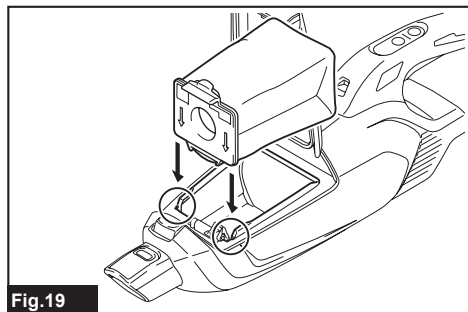

Fig.19

5. Spread the container part of the paper filter inside the cleaner.

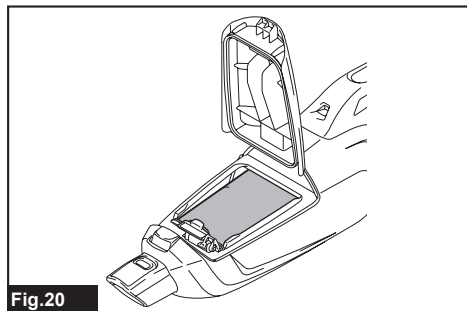

Fig.20

6. Close the front cover completely.

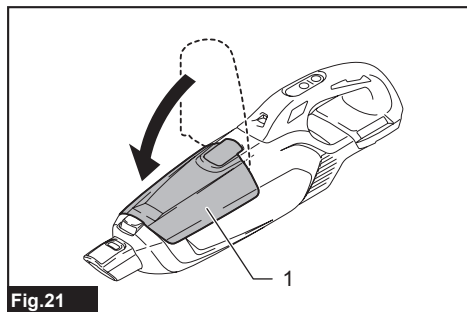

Fig.21

► 1. Front cover

OPERATION

CAUTION: Do not move your face close to the air vent when operating the cleaner. If foreign objects are blown into eyes, it may result in personal injury.

Installing and removing cleaner attachments

CAUTION: After installing attachments, check if they are securely installed. If the attachments are installed imperfectly, they may come off and cause personal injury.

CAUTION: Be careful not to hit your hand on the wall etc. when removing the attachments.

When using attachment with lock function

To install attachment, insert it to the suction inlet of the cleaner until it clicks. Make sure that the attachment is locked.

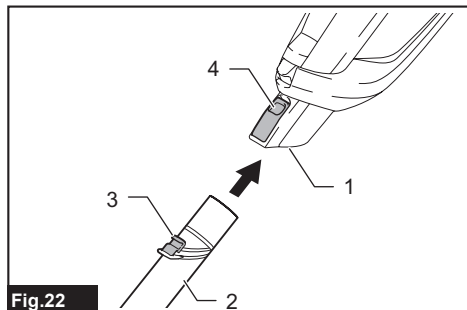

Fig.22

- 1. Suction inlet 2. Attachment with lock function
3. Hook 4. Release button

NOTICE: When installing the attachment with lock function, be sure to align the release button on the cleaner with the hook on the attachment. If they are not aligned, the attachment will not be locked and may come off from the cleaner.

To remove, pull the attachment while pushing the release button.

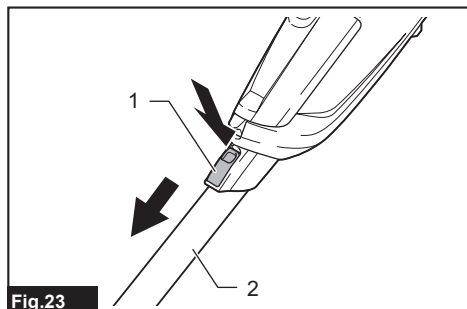

Fig.23

- 1. Release button 2. Attachment with lock function

When using attachment without lock function

NOTICE: To connect attachment without lock function, twist and insert it securely into the suction inlet of the cleaner. To disconnect the attachment, pull it away while twisting.

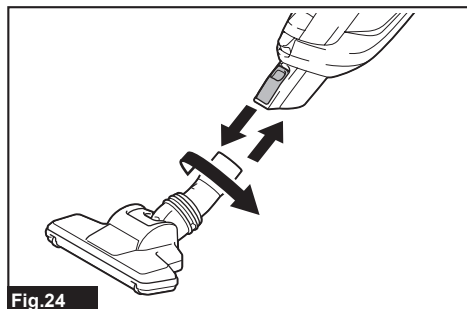

Fig.24

Cleaning (Suction)

Nozzle

Attach the nozzle to clean off tables, desks, furniture, etc. The nozzle slips on easily.

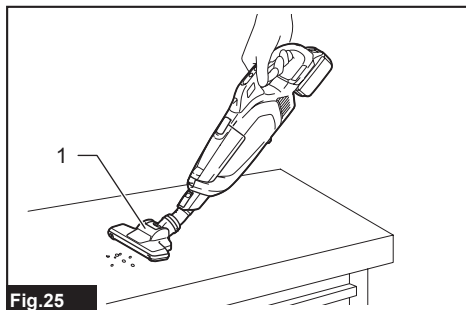

Fig.25

- 1. Nozzle

Nozzle + Extension wand (Straight pipe)

The extension wand fits in between the nozzle and the cleaner itself. This arrangement is convenient for cleaning a floor in a standing position.

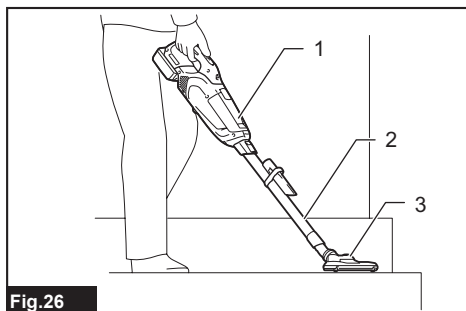

Fig.26

- 1. Cleaner body 2. Extension wand (Straight pipe)
3. Nozzle

Sash nozzle

Fit on the sash nozzle for cleaning corners and crevices of a car or furniture.

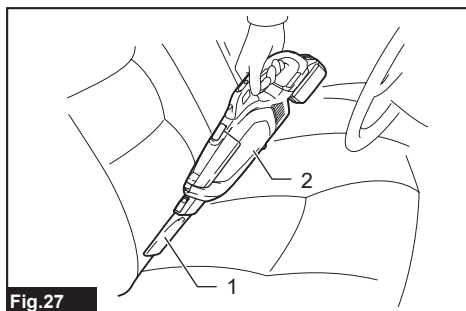

Fig.27

- 1. Sash nozzle 2. Cleaner body

You can store the sash nozzle in the nozzle holder.

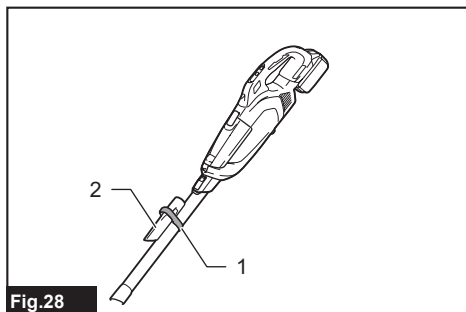

Fig.28

- 1. Nozzle holder 2. Sash nozzle

CAUTION: Be careful not to trap finger(s) between the sash nozzle and the nozzle holder. Trapping finger(s) may cause injury.

Sash nozzle + Extension wand (Straight pipe)

In tight quarters where the cleaner itself cannot squeeze in, or in high places hard to reach, use this arrangement.

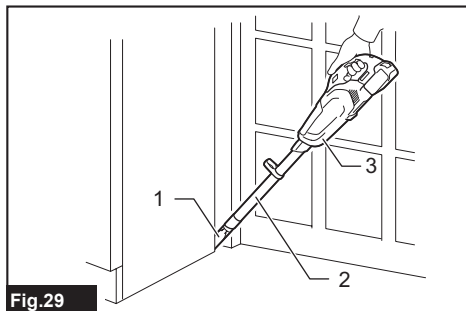

Fig.29

- 1. Sash nozzle 2. Extension wand (Straight pipe)
3. Cleaner body

Cleaning without nozzle

You can pick up powder and dust without nozzle.

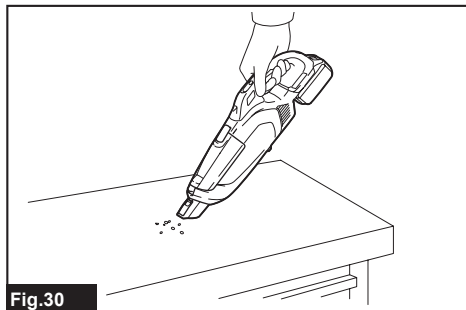

Fig.30

For picking up dust on a floor in a standing position, it is convenient to attach the extension wand to the cleaner.

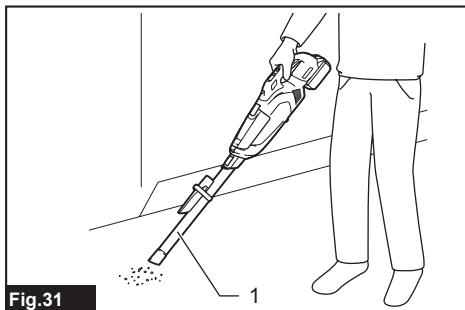

Fig.31

- 1. Extension wand (Straight pipe)

Disposing of dust

CAUTION: Empty the cleaner before it becomes too full, or the suction force weakens.

CAUTION: When closing the front cover, be careful not to pinch your fingers.

NOTICE: Never throw away the dust stopper because it should be used whenever either the dust bag or the paper filter is used.

NOTICE: When the dust bag/paper filter is not inside of the cleaner, the front cover does not close completely. Do not force to close the front cover. It may result in deforming or breakage of the tool.

NOTICE: When disposing of dust, also clean the room for the dust bag/paper filter. The remaining dust and dirt in the room may cause the sponge filter to be clogged or the motor to be damaged.

1. Push the button to open the front cover. Opening it until a click is heard allows a positive stop at that position.

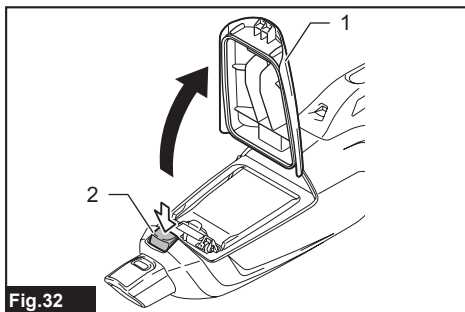

Fig.32

- 1. Front cover 2. Button

2. Pull out both the orange-colored dust stopper and dust bag/paper filter together at the same time.

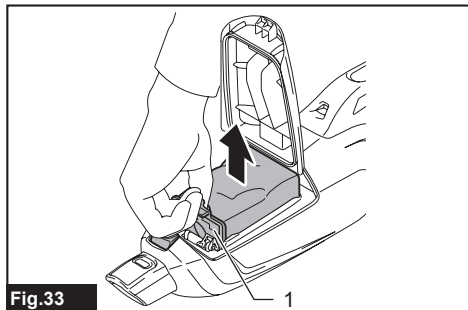

Fig.33

- ▶ 1. Dust stopper

3. Perform the procedures below depending on the dust container type:

When using the dust bag

Remove the dust stopper and empty the dust bag.

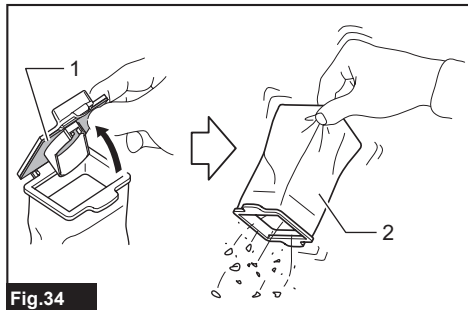

Fig.34

- ▶ 1. Dust stopper 2. Dust bag

When using the paper filter

Remove the dust stopper and dispose of the paper filter.

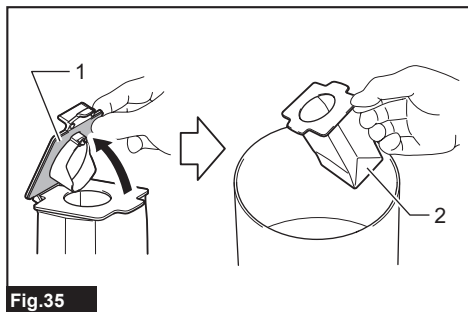

Fig.35

- ▶ 1. Dust stopper 2. Paper filter

4. Place the dust bag/new paper filter and dust stopper together into the cleaner and close the front cover.

NOTE: The cleaner is constructed in such a way that the front cover comes off when trying to force the front cover open at the angle of more than 90°. If the front cover comes off, insert it into the front cover joint in place.

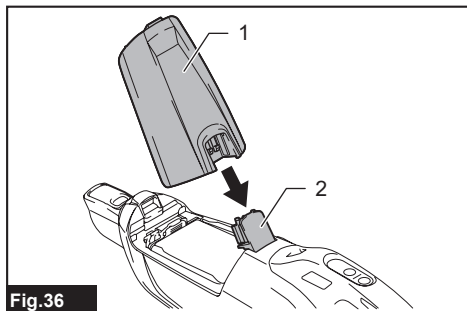

Fig.36

- ▶ 1. Front cover 2. Front cover joint

MAINTENANCE

CAUTION: Always be sure that the tool is switched off and the battery cartridge is removed before attempting to perform inspection or maintenance.

To maintain product SAFETY and RELIABILITY, repairs, any other maintenance or adjustment should be performed by Makita Authorized or Factory Service Centers, always using Makita replacement parts.

After use

CAUTION: Putting the cleaner against the wall without any other support may cause the cleaner to fall down, resulting in personal injury or damage to the cleaner.

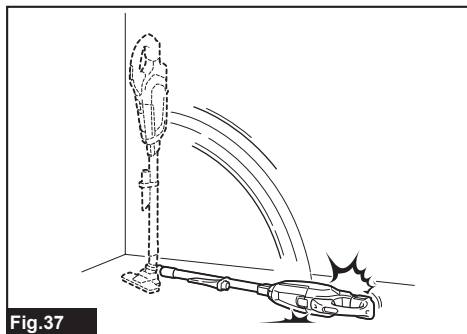

Fig.37

Cleaning

CAUTION: Clean the dust bag and filter when they become clogged. Continuing use in the clogged condition may result in heating or fire.

NOTICE: Never use gasoline, benzine, thinner, alcohol or the like. Discoloration, deformation or cracks may result.

NOTICE: Do not blow dust sticking on the cleaner, dust bag and filter by air duster. It brings dust into the housing and causes failure.

NOTICE: After washing the dust bag and sponge filter, dry them thoroughly before use. Insufficiently dried dust bag and filter may cause poor suction and shorten the service life of the motor.

NOTICE: After cleaning the dust bag and sponge filter, be sure to re-install them before use. If you use the cleaner without the dust bag and sponge filter, dust comes into the motor housing and cause malfunction.

Cleaner body

From time to time wipe off the outside (cleaner body) of the cleaner using a cloth dampened in soapy water. Clean out also the suction opening, dust bag/paper filter mounting area and the dust stopper.

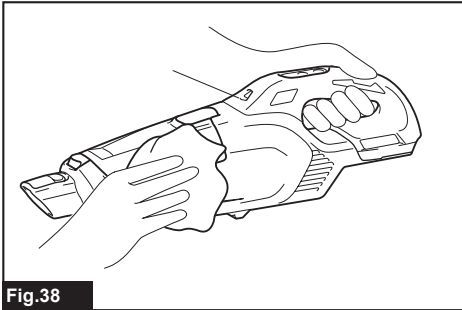

Fig.38

Dust bag

Wash the dust bag in soapy water when it is clogged with dust and the cleaner power becomes weak. Dry it out thoroughly before use. An insufficiently dried dust bag may cause poor suction and shorten the service life of the motor.

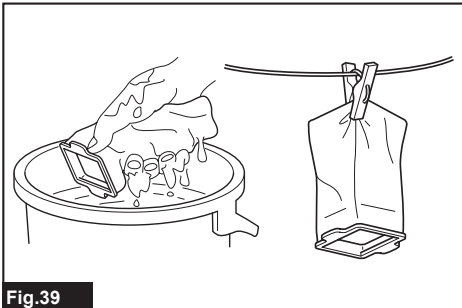

Fig.39

NOTE: Paper filter is a throw-away type.

Dust stopper

Wipe dust off from the dust stopper. Remove dust and dirt on the sponge part by lightly tapping it.

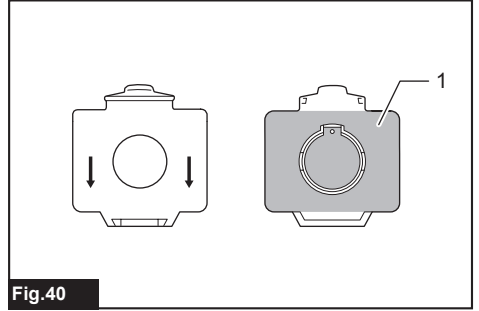

Fig.40

► 1. Sponge part

Removing and installing the sponge filter

CAUTION: After cleaning the sponge filter, be sure to reinstall it on the cleaner. If washed in water, dry it up before installing. An insufficiently dried sponge filter may shorten the service life of the motor.

When the sponge filter is clogged with dust, remove it from the cleaner and then wipe it off or wash in water.

To remove the sponge filter, remove the dust bag or paper filter and then pinch and take the sponge filter out.

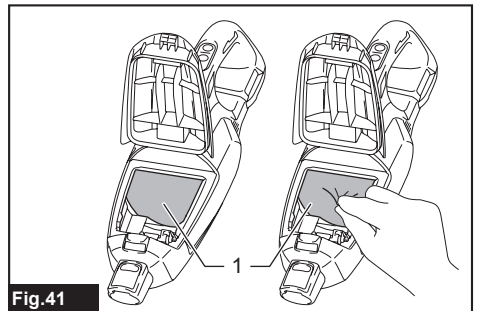

Fig.41

► 1. Sponge filter

To install the sponge filter, press in the whole edge of the sponge filter against the recessed wall inside the dust bag/paper filter mounting area.

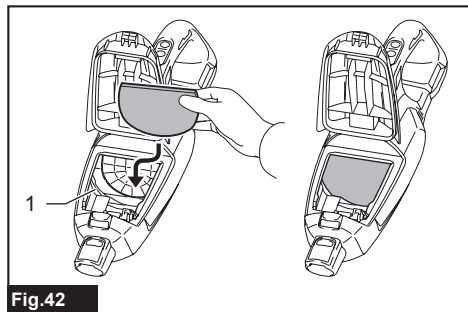

Fig.42

► 1. Recessed wall

Wall mount for cordless cleaner

Optional accessory

NOTE: The screw to mount the holder is not included. Prepare a screw which fits with the material to screw into.

Attach the wall mount for cordless cleaner to a hard wooden wall, beam or column, where the wall mount for cordless cleaner can be firmly secured. Always be sure that the wall mount for cordless cleaner is securely attached before hanging the cleaner.

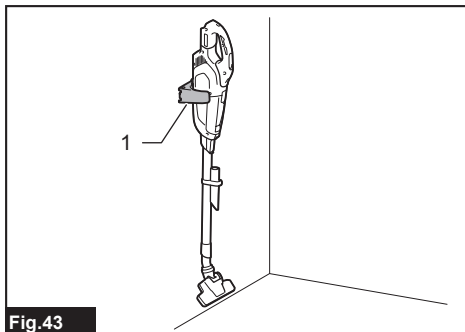

Fig.43

► 1. Wall mount for cordless cleaner

CAUTION: Do not hang the cleaner to the wall mount violently or hang other appliances than the cleaner.

Troubleshooting

Before asking for repairs, check the following points.

Symptom	Area to be investigated	Fixing method
Weak suction power	Is dust bag or paper filter full of dust?	Empty dust bag or paper filter.
	Is dust bag or sponge filter clogged?	Dust down or wash dust bag and sponge filter.
	Is paper filter clogged?	Replace paper filter.
	Is battery cartridge discharged?	Charge battery cartridge.
Not working	Is battery cartridge discharged?	Charge battery cartridge.
Abnormal noise and vibration come out	Is dust bag or sponge filter clogged?	Dust down or wash dust bag and sponge filter.
	Is paper filter clogged?	Replace paper filter.
	Anything to block openings or holes?	Clean any dust and objects out of nozzles, pipes and air openings.
	Is suction inlet of nozzle or pipe closed?	Uncover and open suction inlet of nozzle and pipe.
Front cover does not close	Is dust bag or paper filter set?	Set dust bag or paper filter.

CAUTION: Do not attempt to repair the cleaner by yourself.

OPTIONAL ACCESSORIES

CAUTION: These accessories or attachments are recommended for use with your Makita tool specified in this manual. The use of any other accessories or attachments might present a risk of injury to persons. Only use accessory or attachment for its stated purpose.

If you need any assistance for more details regarding these accessories, ask your local Makita Service Center.

- Extension wand (Straight pipe)
- Nozzle
- Nozzle for carpet
- Shelf brush
- Sash nozzle
- Round brush
- Flexible hose
- Dust bag
- Paper filter
- Seat nozzle
- Crevice nozzle
- Wall mount for cordless cleaner
- Cyclone attachment
- Tool bag
- Makita genuine battery and charger

NOTE: Some items in the list may be included in the tool package as standard accessories. They may differ from country to country.

Cyclone attachment

Optional accessory

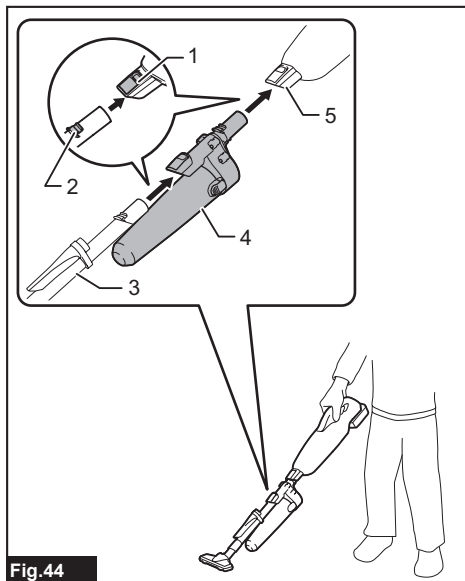

Fig.44

- 1. Release button 2. Hook 3. Extension wand (Straight pipe) 4. Cyclone attachment 5. Suction inlet

About the cyclone attachment

Using the cleaner with the cyclone attachment installed reduces the amount of dust that enters the dust bag and paper filter, which helps to prevent the suction force from weakening. In addition, cleaning after use is also simple.

CAUTION: Always be sure that the tool is switched off and the battery cartridge is removed before carrying out any work on the tool. If the battery cartridge is left inserted, the cleaner may start unexpectedly and result in injury.

CAUTION: Clean the mesh filter of the cyclone attachment and the dust bag of the cleaner unit when they become clogged. Continuing use in the clogged condition may result in heating or smoke.

NOTICE: When the cyclone attachment is attached, do not use the cleaner in a horizontal or upward facing position. Doing so may cause the mesh filter to become clogged.

NOTICE: Always use the cleaner with the dust bag or paper filter installed, even when using the cyclone attachment. Using the cleaner without the dust bag or paper filter installed may result in a motor malfunction.

NOTE: Check that the cyclone attachment, cleaner, and extension wand (straight pipe) are locked properly before use.

NOTE: Empty the dust case of the cyclone attachment and the dust bag or paper filter of the cleaner when dust has accumulated. Continuing use will result in weakened suction force.

NOTE: You can also use the cyclone attachment without lock function.

NOTE: To install or remove the cyclone attachment, refer to the section "Installing and removing cleaner attachments".

Disposing of dust

When dust has accumulated up to the full line of the dust case, follow the procedure below and dispose of the dust.

1. Hold the dust case firmly, press and hold the two buttons, and remove the dust case.

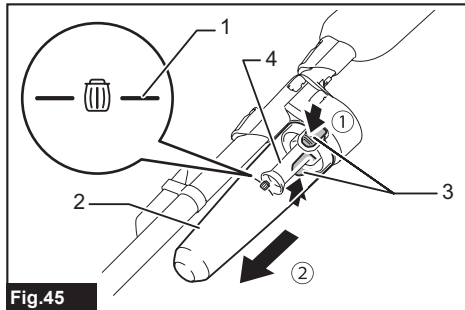

Fig.45
► 1. Full line 2. Dust case 3. Button (two locations)
4. Mesh filter

2. Dispose of the dust inside the dust case and remove any dust and powder adhered to the surface of the mesh filter.
3. Insert the dust case all the way until the two buttons lock with a click.

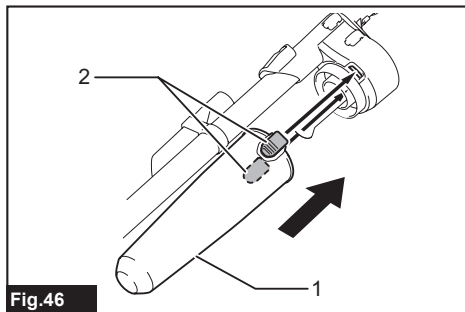

Fig.46
► 1. Dust case 2. Button (two locations)

CAUTION: When reassembling the dust case, be careful not to pinch your fingers.

NOTE: Check that the cyclone attachment, cleaner, and extension wand (straight pipe) are locked properly before restarting operation.

NOTE: If the suction force does not recover even after disposing of the dust and cleaning the mesh filter, check whether dust has accumulated in the dust bag or paper filter of the cleaner or clogging has occurred.

NOTE: The dust may fly up when disposing from the cyclone attachment. Be careful not to let dust get into your eyes.

Cleaning

CAUTION: After washing the cyclone attachment, dry it thoroughly before use. Insufficiently dried components may cause an electrical shock or damage to the appliance.

When the dust case becomes dirty or the mesh filter is clogged, remove and wash them with water. (Refer to "Disposing of dust" for the removal procedure.)

Dry the parts thoroughly before reinstallation and use.

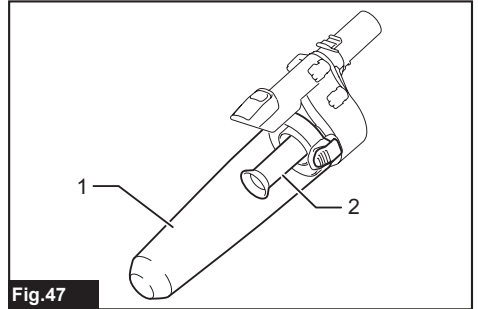

Fig.47
► 1. Dust case 2. Mesh filter

When the mesh filter gets dirty badly, clean it in the following procedures.

1. Turn the mesh filter in the direction of the arrow and remove it while the hooks are unlocked.

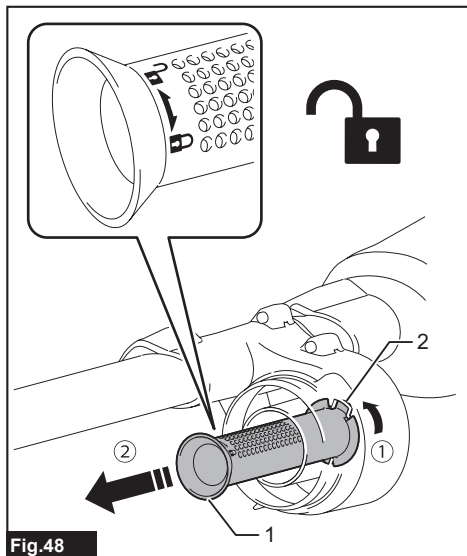

Fig.48

- 1. Mesh filter 2. Hook

2. Remove the dust on the mesh filter and then wash it with water. After that, dry it thoroughly.

3. Insert the mesh filter into the base while the hooks are aligned with the port. Turn the mesh filter in the direction of the arrow until the hooks are locked with a click. Make sure that the mesh filter is installed securely.

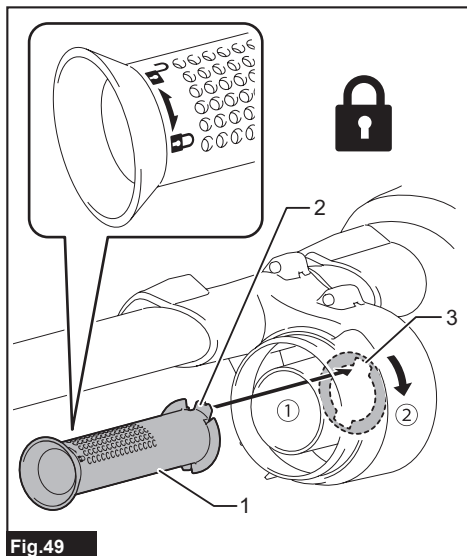

Fig.49

- 1. Mesh filter 2. Hook 3. Port

Makita Europe N.V. Jan-Baptist Vinkstraat 2,
3070 Kortenberg, Belgium

Makita Corporation 3-11-8, Sumiyoshi-cho,
Anjo, Aichi 446-8502 Japan

www.makita.com

885A26-223 EN 20221111
