

INSTRUCTION MANUAL

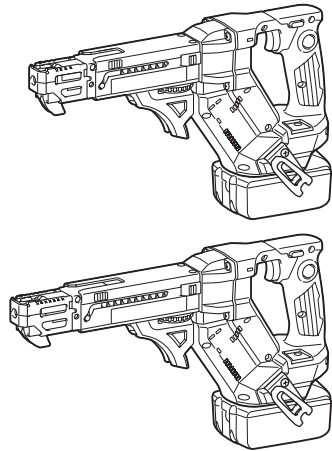

Cordless Auto Feed Screwdriver

DFR452
DFR551



Read before use.

SPECIFICATIONS

Model:	DFR452	DFR551
Screw strip	ø3.5 mm x 20 mm - ø4.2 mm x 41 mm	ø3.5 mm x 25 mm - ø4.2 mm x 55 mm
No load speed (RPM)	0 - 6,000 min ⁻¹	
Overall length	360 mm	396 mm
Rated voltage	D.C. 18 V	
Net weight	1.9 - 2.2 kg	

- Due to our continuing program of research and development, the specifications herein are subject to change without notice.
- Specifications may differ from country to country.
- The weight may differ depending on the attachment(s), including the battery cartridge. The lightest and heaviest combination, according to EPTA-Procedure 01/2014, are shown in the table.

Applicable battery cartridge and charger

Battery cartridge	BL1815N / BL1820B / BL1830B / BL1840B / BL1850B / BL1860B
Charger	DC18RC / DC18RD / DC18RE / DC18SD / DC18SE / DC18SF / DC18SH / DC18WC

- Some of the battery cartridges and chargers listed above may not be available depending on your region of residence.

⚠ WARNING: Only use the battery cartridges and chargers listed above. Use of any other battery cartridges and chargers may cause injury and/or fire.

Symbols

The followings show the symbols which may be used for the equipment. Be sure that you understand their meaning before use.



Read instruction manual.



Only for EU countries
Due to the presence of hazardous components in the equipment, waste electrical and electronic equipment, accumulators and batteries may have a negative impact on the environment and human health. Do not dispose of electrical and electronic appliances or batteries with household waste!
In accordance with the European Directive on waste electrical and electronic equipment and on accumulators and batteries and waste accumulators and batteries, as well as their adaptation to national law, waste electrical equipment, batteries and accumulators should be stored separately and delivered to a separate collection point for municipal waste, operating in accordance with the regulations on environmental protection.
This is indicated by the symbol of the crossed-out wheeled bin placed on the equipment.

Intended use

The tool is intended for screw driving in wood, metal and plastic.

Noise

The typical A-weighted noise level determined according to EN62841-2-2:

Model DFR452

Sound pressure level (L_{pA}) : 75 dB(A)

Uncertainty (K) : 3 dB(A)

Model DFR551

Sound pressure level (L_{pA}) : 74 dB(A)

Uncertainty (K) : 3 dB(A)

The noise level under working may exceed 80 dB (A).

NOTE: The declared noise emission value(s) has been measured in accordance with a standard test method and may be used for comparing one tool with another.

NOTE: The declared noise emission value(s) may also be used in a preliminary assessment of exposure.

⚠ WARNING: Wear ear protection.

⚠ WARNING: The noise emission during actual use of the power tool can differ from the declared value(s) depending on the ways in which the tool is used especially what kind of workpiece is processed.

⚠ WARNING: Be sure to identify safety measures to protect the operator that are based on an estimation of exposure in the actual conditions of use (taking account of all parts of the operating cycle such as the times when the tool is switched off and when it is running idle in addition to the trigger time).

Vibration

The vibration total value (tri-axial vector sum) determined according to EN62841-2-2:

Model DFR452

Work mode: screwdriving without impact
Vibration emission (a_{hv}): 2.5 m/s² or less
Uncertainty (K): 1.5 m/s²

Model DFR551

Work mode: screwdriving without impact
Vibration emission (a_{hv}): 2.5 m/s² or less
Uncertainty (K): 1.5 m/s²

NOTE: The declared vibration total value(s) has been measured in accordance with a standard test method and may be used for comparing one tool with another.

NOTE: The declared vibration total value(s) may also be used in a preliminary assessment of exposure.

⚠WARNING: The vibration emission during actual use of the power tool can differ from the declared value(s) depending on the ways in which the tool is used especially what kind of workpiece is processed.

⚠WARNING: Be sure to identify safety measures to protect the operator that are based on an estimation of exposure in the actual conditions of use (taking account of all parts of the operating cycle such as the times when the tool is switched off and when it is running idle in addition to the trigger time).

Declarations of Conformity

For European countries only

The Declarations of conformity are included in Annex A to this instruction manual.

SAFETY WARNINGS

General power tool safety warnings

⚠WARNING Read all safety warnings, instructions, illustrations and specifications provided with this power tool. Failure to follow all instructions listed below may result in electric shock, fire and/or serious injury.

Save all warnings and instructions for future reference.

The term "power tool" in the warnings refers to your mains-operated (corded) power tool or battery-operated (cordless) power tool.

Work area safety

1. **Keep work area clean and well lit.** Cluttered or dark areas invite accidents.
2. **Do not operate power tools in explosive atmospheres, such as in the presence of flammable liquids, gases or dust.** Power tools create sparks which may ignite the dust or fumes.
3. **Keep children and bystanders away while operating a power tool.** Distractions can cause you to lose control.

Electrical safety

1. **Power tool plugs must match the outlet. Never modify the plug in any way. Do not use any adapter plugs with earthed (grounded) power tools.** Unmodified plugs and matching outlets will reduce risk of electric shock.
2. **Avoid body contact with earthed or grounded surfaces, such as pipes, radiators, ranges and refrigerators.** There is an increased risk of electric shock if your body is earthed or grounded.
3. **Do not expose power tools to rain or wet conditions.** Water entering a power tool will increase the risk of electric shock.
4. **Do not abuse the cord. Never use the cord for carrying, pulling or unplugging the power tool. Keep cord away from heat, oil, sharp edges or moving parts.** Damaged or entangled cords increase the risk of electric shock.
5. **When operating a power tool outdoors, use an extension cord suitable for outdoor use.** Use of a cord suitable for outdoor use reduces the risk of electric shock.
6. **If operating a power tool in a damp location is unavoidable, use a residual current device (RCD) protected supply.** Use of an RCD reduces the risk of electric shock.
7. **Power tools can produce electromagnetic fields (EMF) that are not harmful to the user.** However, users of pacemakers and other similar medical devices should contact the maker of their device and/or doctor for advice before operating this power tool.

Personal safety

1. **Stay alert, watch what you are doing and use common sense when operating a power tool. Do not use a power tool while you are tired or under the influence of drugs, alcohol or medication.** A moment of inattention while operating power tools may result in serious personal injury.
2. **Use personal protective equipment. Always wear eye protection.** Protective equipment such as a dust mask, non-skid safety shoes, hard hat or hearing protection used for appropriate conditions will reduce personal injuries.
3. **Prevent unintentional starting. Ensure the switch is in the off-position before connecting to power source and/or battery pack, picking up or carrying the tool.** Carrying power tools with your finger on the switch or energising power tools that have the switch on invites accidents.
4. **Remove any adjusting key or wrench before turning the power tool on.** A wrench or a key left attached to a rotating part of the power tool may result in personal injury.
5. **Do not overreach. Keep proper footing and balance at all times.** This enables better control of the power tool in unexpected situations.
6. **Dress properly. Do not wear loose clothing or jewellery. Keep your hair and clothing away from moving parts.** Loose clothes, jewellery or long hair can be caught in moving parts.
7. **If devices are provided for the connection of dust extraction and collection facilities, ensure these are connected and properly used.** Use of dust collection can reduce dust-related hazards.

8. **Do not let familiarity gained from frequent use of tools allow you to become complacent and ignore tool safety principles.** A careless action can cause severe injury within a fraction of a second.
9. **Always wear protective goggles to protect your eyes from injury when using power tools.** The goggles must comply with ANSI Z87.1 in the USA, EN 166 in Europe, or AS/NZS 1336 in Australia/New Zealand. In Australia/New Zealand, it is legally required to wear a face shield to protect your face, too.

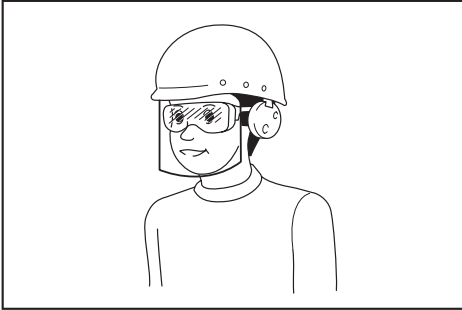

It is an employer's responsibility to enforce the use of appropriate safety protective equipments by the tool operators and by other persons in the immediate working area.

Power tool use and care

1. **Do not force the power tool. Use the correct power tool for your application.** The correct power tool will do the job better and safer at the rate for which it was designed.
2. **Do not use the power tool if the switch does not turn it on and off.** Any power tool that cannot be controlled with the switch is dangerous and must be repaired.
3. **Disconnect the plug from the power source and/or remove the battery pack, if detachable, from the power tool before making any adjustments, changing accessories, or storing power tools.** Such preventive safety measures reduce the risk of starting the power tool accidentally.
4. **Store idle power tools out of the reach of children and do not allow persons unfamiliar with the power tool or these instructions to operate the power tool.** Power tools are dangerous in the hands of untrained users.
5. **Maintain power tools and accessories. Check for misalignment or binding of moving parts, breakage of parts and any other condition that may affect the power tool's operation. If damaged, have the power tool repaired before use.** Many accidents are caused by poorly maintained power tools.
6. **Keep cutting tools sharp and clean.** Properly maintained cutting tools with sharp cutting edges are less likely to bind and are easier to control.
7. **Use the power tool, accessories and tool bits etc. in accordance with these instructions, taking into account the working conditions and the work to be performed.** Use of the power tool for operations different from those intended could result in a hazardous situation.

8. **Keep handles and grasping surfaces dry, clean and free from oil and grease.** Slippery handles and grasping surfaces do not allow for safe handling and control of the tool in unexpected situations.
9. **When using the tool, do not wear cloth work gloves which may be entangled.** The entanglement of cloth work gloves in the moving parts may result in personal injury.

Battery tool use and care

1. **Recharge only with the charger specified by the manufacturer.** A charger that is suitable for one type of battery pack may create a risk of fire when used with another battery pack.
2. **Use power tools only with specifically designated battery packs.** Use of any other battery packs may create a risk of injury and fire.
3. **When battery pack is not in use, keep it away from other metal objects, like paper clips, coins, keys, nails, screws or other small metal objects, that can make a connection from one terminal to another.** Shorting the battery terminals together may cause burns or a fire.
4. **Under abusive conditions, liquid may be ejected from the battery; avoid contact. If contact accidentally occurs, flush with water. If liquid contacts eyes, additionally seek medical help.** Liquid ejected from the battery may cause irritation or burns.
5. **Do not use a battery pack or tool that is damaged or modified.** Damaged or modified batteries may exhibit unpredictable behaviour resulting in fire, explosion or risk of injury.
6. **Do not expose a battery pack or tool to fire or excessive temperature.** Exposure to fire or temperature above 130 °C may cause explosion.
7. **Follow all charging instructions and do not charge the battery pack or tool outside the temperature range specified in the instructions.** Charging improperly or at temperatures outside the specified range may damage the battery and increase the risk of fire.

Service

1. **Have your power tool serviced by a qualified repair person using only identical replacement parts.** This will ensure that the safety of the power tool is maintained.
2. **Never service damaged battery packs.** Service of battery packs should only be performed by the manufacturer or authorized service providers.
3. **Follow instruction for lubricating and changing accessories.**

Cordless screwdriver safety warnings

1. **Hold the power tool by insulated gripping surfaces, when performing an operation where the fastener may contact hidden wiring.** Fasteners contacting a "live" wire may make exposed metal parts of the power tool "live" and could give the operator an electric shock.
2. **Always be sure you have a firm footing. Be sure no one is below when using the tool in high locations.**
3. **Hold the tool firmly.**
4. **Keep hands away from rotating parts.**

5. **Do not touch the bit or the workpiece immediately after operation; they may be extremely hot and could burn your skin.**
6. **Always secure workpiece in a vise or similar hold-down device.**
7. **Make sure there are no electrical cables, water pipes, gas pipes etc. that could cause a hazard if damaged by use of the tool.**

SAVE THESE INSTRUCTIONS.

⚠WARNING: DO NOT let comfort or familiarity with product (gained from repeated use) replace strict adherence to safety rules for the subject product.

MISUSE or failure to follow the safety rules stated in this instruction manual may cause serious personal injury.

Important safety instructions for battery cartridge

1. **Before using battery cartridge, read all instructions and cautionary markings on (1) battery charger, (2) battery, and (3) product using battery.**
2. **Do not disassemble or tamper with the battery cartridge.** It may result in a fire, excessive heat, or explosion.
3. **If operating time has become excessively shorter, stop operating immediately.** It may result in a risk of overheating, possible burns and even an explosion.
4. **If electrolyte gets into your eyes, rinse them out with clear water and seek medical attention right away.** It may result in loss of your eyesight.
5. **Do not short the battery cartridge:**
 - (1) **Do not touch the terminals with any conductive material.**
 - (2) **Avoid storing battery cartridge in a container with other metal objects such as nails, coins, etc.**
 - (3) **Do not expose battery cartridge to water or rain.**

A battery short can cause a large current flow, overheating, possible burns and even a breakdown.

6. **Do not store and use the tool and battery cartridge in locations where the temperature may reach or exceed 50 °C (122 °F).**
7. **Do not incinerate the battery cartridge even if it is severely damaged or is completely worn out.** The battery cartridge can explode in a fire.
8. **Do not nail, cut, crush, throw, drop the battery cartridge, or hit against a hard object to the battery cartridge.** Such conduct may result in a fire, excessive heat, or explosion.
9. **Do not use a damaged battery.**
10. **The contained lithium-ion batteries are subject to the Dangerous Goods Legislation requirements.** For commercial transports e.g. by third parties, forwarding agents, special requirement on packaging and labeling must be observed.

For preparation of the item being shipped, consulting an expert for hazardous material is required. Please also observe possibly more detailed national regulations.

Tape or mask off open contacts and pack up the battery in such a manner that it cannot move around in the packaging.

11. **When disposing the battery cartridge, remove it from the tool and dispose of it in a safe place.** Follow your local regulations relating to disposal of battery.
12. **Use the batteries only with the products specified by Makita.** Installing the batteries to non-compliant products may result in a fire, excessive heat, explosion, or leak of electrolyte.
13. **If the tool is not used for a long period of time, the battery must be removed from the tool.**
14. **During and after use, the battery cartridge may take on heat which can cause burns or low temperature burns.** Pay attention to the handling of hot battery cartridges.
15. **Do not touch the terminal of the tool immediately after use as it may get hot enough to cause burns.**
16. **Do not allow chips, dust, or soil stuck into the terminals, holes, and grooves of the battery cartridge.** It may cause heating, catching fire, burst and malfunction of the tool or battery cartridge, resulting in burns or personal injury.
17. **Unless the tool supports the use near high-voltage electrical power lines, do not use the battery cartridge near high-voltage electrical power lines.** It may result in a malfunction or breakdown of the tool or battery cartridge.
18. **Keep the battery away from children.**

SAVE THESE INSTRUCTIONS.

⚠CAUTION: Only use genuine Makita batteries. Use of non-genuine Makita batteries, or batteries that have been altered, may result in the battery bursting causing fires, personal injury and damage. It will also void the Makita warranty for the Makita tool and charger.

Tips for maintaining maximum battery life

1. **Charge the battery cartridge before completely discharged.** Always stop tool operation and charge the battery cartridge when you notice less tool power.
2. **Never recharge a fully charged battery cartridge.** Overcharging shortens the battery service life.
3. **Charge the battery cartridge with room temperature at 10 °C - 40 °C (50 °F - 104 °F).** Let a hot battery cartridge cool down before charging it.
4. **When not using the battery cartridge, remove it from the tool or the charger.**
5. **Charge the battery cartridge if you do not use it for a long period (more than six months).**

FUNCTIONAL DESCRIPTION

CAUTION: Always be sure that the tool is switched off and the battery cartridge is removed before adjusting or checking function on the tool.

Installing or removing battery cartridge

CAUTION: Always switch off the tool before installing or removing of the battery cartridge.

CAUTION: Hold the tool and the battery cartridge firmly when installing or removing battery cartridge. Failure to hold the tool and the battery cartridge firmly may cause them to slip off your hands and result in damage to the tool and battery cartridge and a personal injury.

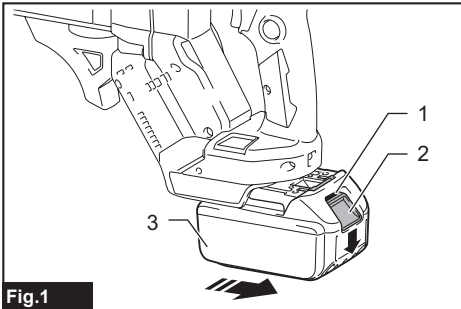

Fig.1

► 1. Red indicator 2. Button 3. Battery cartridge

To remove the battery cartridge, slide it from the tool while sliding the button on the front of the cartridge.

To install the battery cartridge, align the tongue on the battery cartridge with the groove in the housing and slip it into place. Insert it all the way until it locks in place with a little click. If you can see the red indicator as shown in the figure, it is not locked completely.

CAUTION: Always install the battery cartridge fully until the red indicator cannot be seen. If not, it may accidentally fall out of the tool, causing injury to you or someone around you.

CAUTION: Do not install the battery cartridge forcibly. If the cartridge does not slide in easily, it is not being inserted correctly.

Tool / battery protection system

The tool is equipped with a tool/battery protection system. This system automatically cuts off power to the motor to extend tool and battery life. The tool will automatically stop during operation if the tool or battery is placed under one of the following conditions:

Overload protection

When the tool/battery is operated in a manner that causes it to draw an abnormally high current, the tool stops automatically. In this situation, turn the tool off and stop the application that caused the tool to become overloaded. Then turn the tool on to restart.

Overheat protection

When the tool/battery is overheated, the tool stops automatically. In this situation, let the tool/battery cool before turning the tool on again.

Overdischarge protection

When the battery capacity is not enough, the tool stops automatically. In this case, remove the battery from the tool and charge the battery.

Alert indicator

The indicator lamp on the push drive mode selector raises an alert with flashing red lights when the tool works in the following operating conditions.

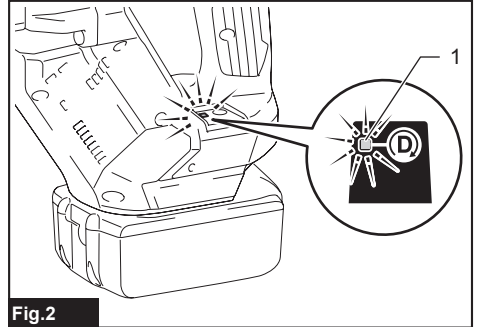

Fig.2

► 1. Indicator lamp

Lamp status	Causes	Remedies
Fast flashing (approx. one-third second intervals)	Battery getting low	Charge the battery at your earliest opportunity.
Delayed flashing (approx. a second intervals)	Overheated	Let the tool cool down before turning it on again.

NOTE: An over-discharge alert may appear depending on the battery status and operational conditions.

Indicating the remaining battery capacity

Only for battery cartridges with the indicator

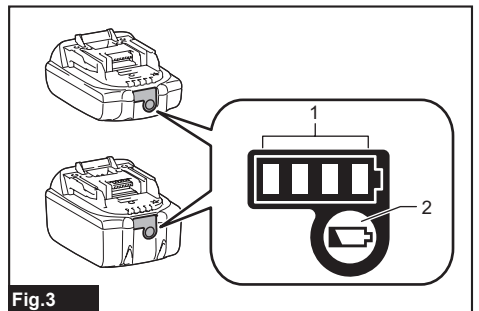

Fig.3

► 1. Indicator lamps 2. Check button

Press the check button on the battery cartridge to indicate the remaining battery capacity. The indicator lamps light up for a few seconds.

Indicator lamps			Remaining capacity
Lighted	Off	Blinking	
■	□	▧	75% to 100%
■ ■ ■ ■	□ □ □ □		50% to 75%
■ ■ □ □	□ □ □ □		25% to 50%
■ □ □ □	□ □ □ □		0% to 25%
▧ □ □ □	□ □ □ □		Charge the battery.
■ ■ □ □	□ □ □ □		The battery may have malfunctioned.
□ □ ■ ■	□ □ □ □		

NOTE: Depending on the conditions of use and the ambient temperature, the indication may differ slightly from the actual capacity.

NOTE: The first (far left) indicator lamp will blink when the battery protection system works.

Setting for desired screw lengths

For model DFR452

The tool provides 4 positive-lock screw length settings. Slide the stopper base out and in while depressing the levers on the top surface of the stopper base so the number for desired screw length (indicated on the label) appears in the reading window. See the following table for details on the numbers allocated to your desired screw lengths.

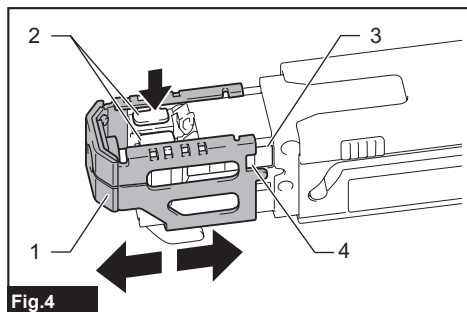

Fig.4

- 1. Stopper base 2. Levers 3. Label 4. Reading window

Numbers indicated on the label	Screw length ranges
20	20 mm (3/4")
25	25 mm - 28 mm (1" - 1-1/8")
32	28 mm - 35 mm (1-1/8" - 1-3/8")
41	35 mm - 41 mm (1-3/8" - 1-5/8")

For model DFR551

The tool provides 7 positive-lock screw length settings. Slide the stopper base out and in while depressing the levers on the top surface of the stopper base so the number for desired screw length (indicated on the label) appears in the reading window. See the following table for details on the numbers allocated to your desired screw lengths.

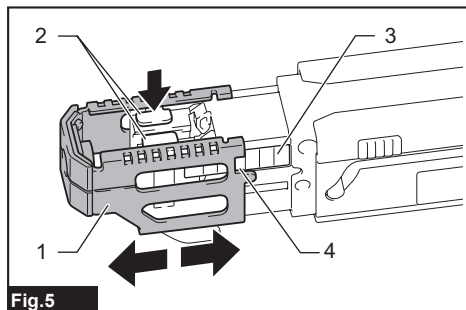

Fig.5

- 1. Stopper base 2. Levers 3. Label 4. Reading window

Numbers indicated on the label	Screw length ranges
25	25 mm (1")
30	25 mm - 30 mm (1" - 1-3/16")
35	30 mm - 35 mm (1-3/16" - 1-3/8")
40	35 mm - 40 mm (1-3/8" - 1-9/16")
45	40 mm - 45 mm (1-9/16" - 1-3/4")
50	45 mm - 50 mm (1-3/4" - 2")
55	50 mm - 55 mm (2" - 2-3/16")

Adjusting driving depths

Press the front face of the stopper base and hold the feeder box down into the casing as far as it will go. While keeping it in that position, turn the adjusting dial so that the driver bit tip comes out approximately 6 mm from the front face of the stopper base. Drive a trial screw. If the screw head stands above the workpiece surface, turn the adjusting dial in the A direction; if the screw head sits below the surface, turn the adjusting dial in the B direction.

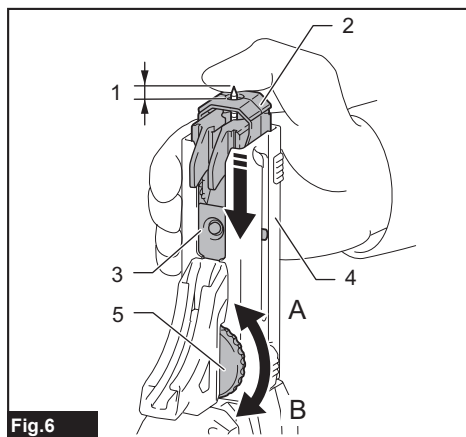

Fig.6

- 1. Approx. 6 mm 2. Stopper base 3. Feeder box 4. Casing 5. Adjusting dial

Switch action

⚠ WARNING: Before installing the battery cartridge into the tool, always check to see that the switch trigger actuates properly and returns to the "OFF" position when released.

To start the tool, pull the switch trigger. Tool speed is increased by increasing pressure on the switch trigger. Release the switch trigger to stop. For continuous operation, pull the switch trigger, push in the lock button and then release the trigger. To stop the tool from the locked position, pull the switch trigger fully, and then release it.

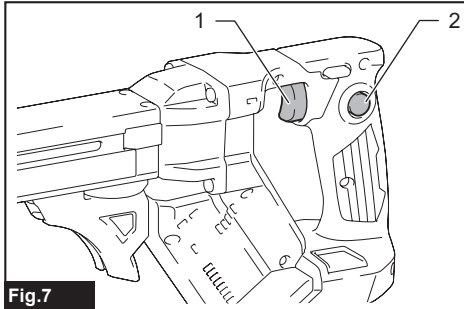

Fig.7

► 1. Switch trigger 2. Lock button

Reversing switch action

⚠ CAUTION: Always check the direction of rotation before operation.

⚠ CAUTION: Use the reversing switch only after the tool comes to a complete stop. Changing the direction of rotation before the tool stops may damage the tool.

⚠ CAUTION: When not operating the tool, always set the reversing switch lever to the neutral position.

This tool has a reversing switch to change the direction of rotation. Depress the reversing switch lever from the A side for clockwise rotation or from the B side for counterclockwise rotation.

When the reversing switch lever is in the neutral position, the switch trigger cannot be pulled.

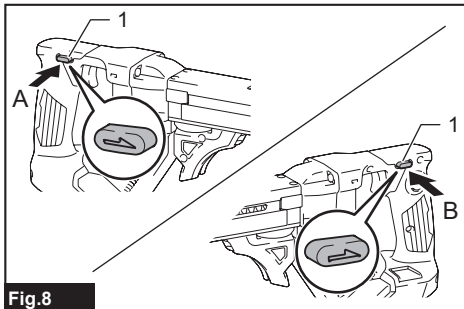

Fig.8

► 1. Reversing switch lever

Push drive mode

In push drive mode, the driver bit only rotates by applying pressure onto the driving surface with the stopper base, allowing the tool to cut off power to the motor to save battery power at idle.

To select push drive mode, pull the switch trigger slightly, then release it and quickly press the mode select button. The indicator lamp on the push drive mode selector will then light up.

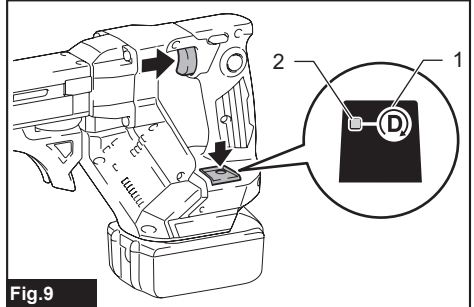

Fig.9

► 1. Mode select button 2. Indicator lamp

NOTE: Push drive mode will automatically be deactivated after eight hours with the switch trigger locked on and no further switch operation. To restart the tool, pull the switch trigger fully to release the lock button, and pull the trigger again.

ASSEMBLY

⚠ CAUTION: Always be sure that the tool is switched off and the battery cartridge is removed before carrying out any work on the tool.

Removing and installing driver bit

⚠ CAUTION: Be careful not to touch the sharp edges of screws while reassembling the components and attachments.

⚠ CAUTION: Handle accessories and attachments with care. Always be sure to hold accessories and attachments body firmly when installation and uninstallation to avoid them falling or slipping off from your hands.

1. Press and hold the release buttons on each side of the casing, and then pull the casing apart.

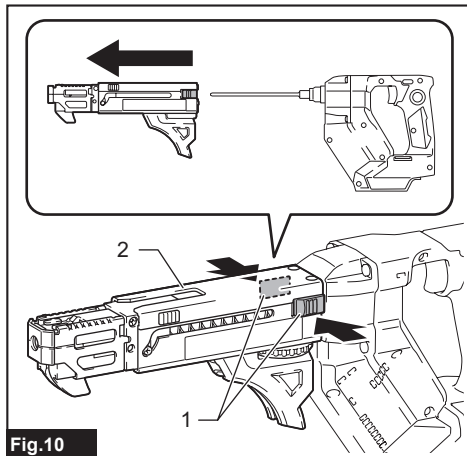

Fig.10

- 1. Release buttons 2. Casing

2. To remove the driver bit, pull it off while pushing and holding the spindle into the gear housing.

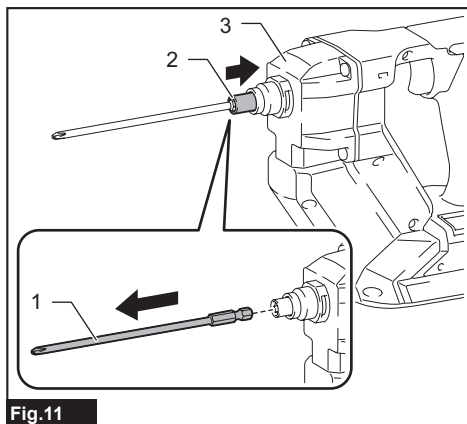

Fig.11

- 1. Driver bit 2. Spindle 3. Gear housing

3. To install a driver bit, place it into the spindle hole as far as it will go while pushing and holding the spindle into the gear housing. Then release the spindle to secure the driver bit.

4. Reset the casing back onto the gear housing while holding its body firmly until the release buttons on each side of the casing lock in place.

Installing screw strip

Insert a screw strip through the screw strip guide on the casing, and then insert it through the screw loading guide in the feeder box.

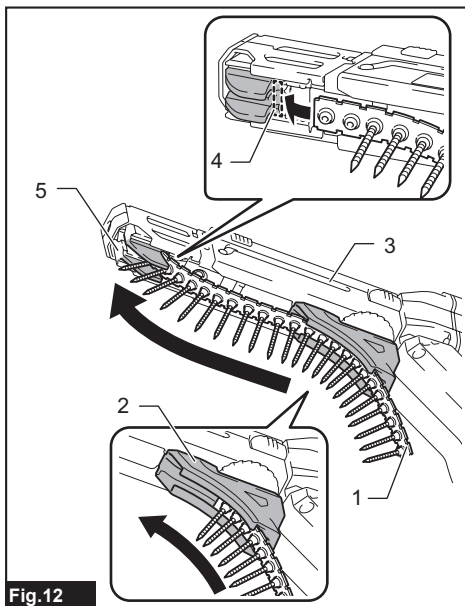

Fig.12

- 1. Screw strip 2. Screw strip guide 3. Casing
4. Screw loading guide 5. Feeder box

NOTICE: Make sure to set the first screw in the second row next to the driving position.

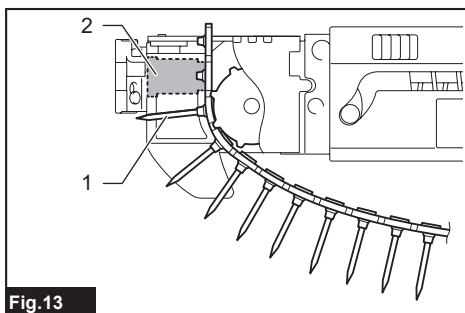

Fig.13

- 1. First screw 2. Driving position

Removing screw strip

To remove the screw strip, pull it upwards out of the feeder box.

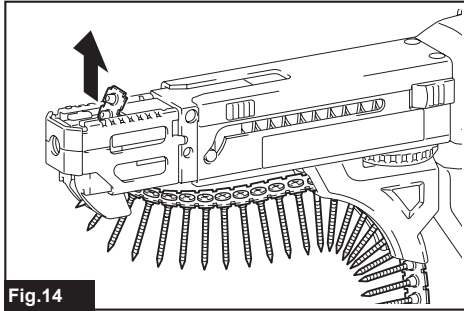

Fig.14

The screw strip can be pulled downwards out of the feeder box while pressing the reverse button on the feeder box.

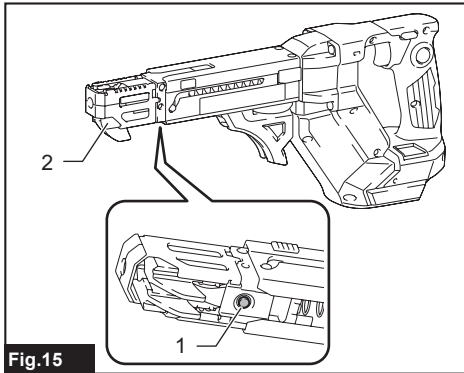

Fig.15

► 1. Reverse button 2. Feeder box

Installing hook

⚠WARNING: Use the hanging/mounting parts for their intended purposes only, e.g., hanging the tool on a tool belt between jobs or work intervals.

⚠WARNING: Be careful not to overload the hook as too much force or irregular overburden may cause damages to the tool resulting in personal injury.

⚠CAUTION: When installing the hook, always secure it with the screw firmly. If not, the hook may come off from the tool and result in the personal injury.

⚠CAUTION: Make sure to hang the tool securely before releasing your hold. Insufficient or unbalanced hooking may cause falling off and you may be injured.

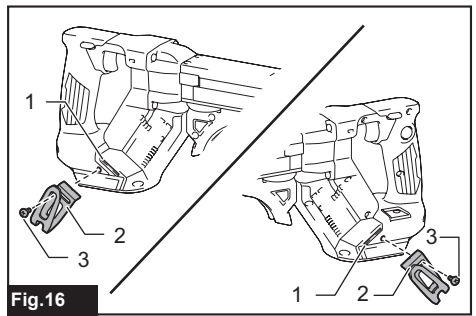

Fig.16

► 1. Groove 2. Hook 3. Screw

The hook is convenient for temporarily hanging the tool. This can be installed on either side of the tool. To install the hook, insert it into a groove in the tool housing on either side and then secure it with a screw. To remove, loosen the screw and then take it out.

Using hole

⚠WARNING: Never use the hanging hole for unintended purpose, for instance, tethering the tool at high location. Bearing stress in a heavily loaded hole may cause damages to the hole, resulting in injuries to you or people around or below you.

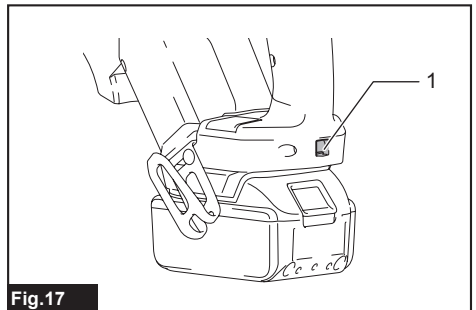

Fig.17

► 1. Hanging hole

Use the hanging hole at the bottom rear of the tool to hang the tool on a wall using a hanging cord or similar strings.

OPERATION

Driving operation

NOTICE: Always check the driver bit carefully for wear before driving operations. Replace a worn driver bit or poor fastening may result.

NOTICE: Always hold the tool squarely against the driving surface. Holding it at an angle may damage the screw heads and cause wear on the driver bit. This may also lead to poor fastening.

NOTICE: Always keep the tool firmly against the driving surface until the driving is over. Failure to do so may cause insufficient fastening of screws.

NOTICE: Be careful not to drive a screw onto another screw already fastened.

NOTICE: Do not operate the tool without screws. It will damage the driving surface.

NOTICE: Do not apply oil or grease on the sliding surface of the feeder box.

Switch on the tool by pulling the switch trigger. Hold the tool squarely and firmly up against the driving surface. A screw will be automatically carried to the driving position and fastened.

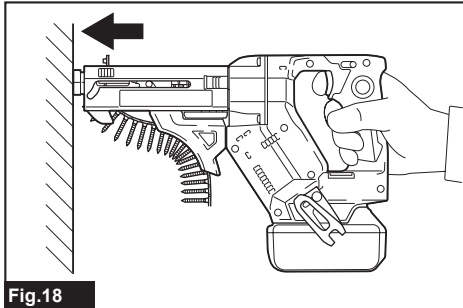

Fig.18

Driving operation in push drive mode

1. Pull the switch trigger slightly and release it. Then quickly press the mode select button.

The indicator lamp on the push drive mode selector lights up, and push drive mode becomes activated.

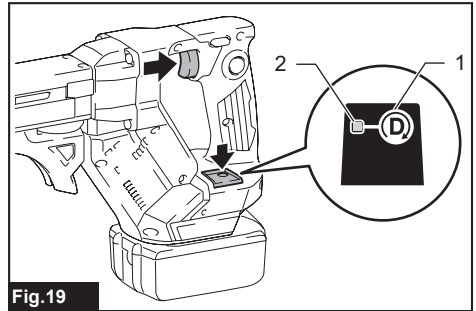

Fig.19

► 1. Mode select button 2. Indicator lamp

2. Depress the lock button while pulling the switch trigger, and then release the switch trigger.

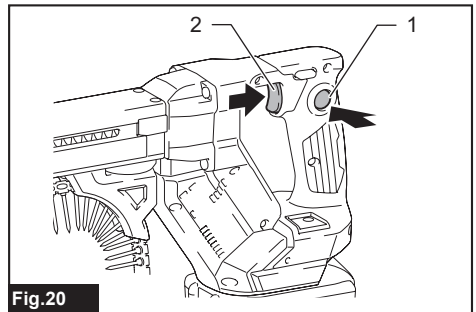

Fig.20

► 1. Lock button 2. Switch trigger

NOTE: While selecting push drive mode and locking the trigger on, the motor does not rotate under no load to minimize power consumption.

3. Hold the tool squarely against the driving surface and apply forward pressure to the tool.

The screw will be automatically carried to the driving position and driven at full speed.

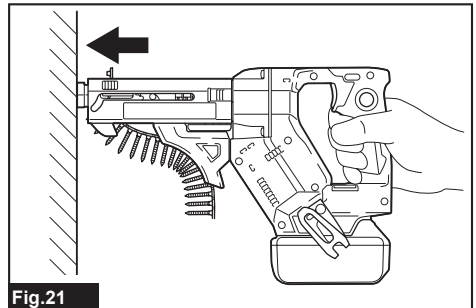

Fig.21

Driving in corner

CAUTION: Driving at a position closer than 15 mm to the wall or driving with the stopper base in contact with the wall may damage the screw heads and cause wear on the driver bit. This may also lead to poor fastening of screws and malfunction of the tool.

This tool can be used to drive at a position 15 mm away from the wall as shown in the figure.

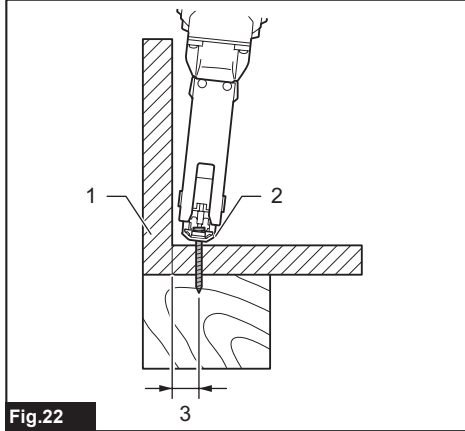

Fig.22

► 1. Wall 2. Stopper base 3. 15 mm

Unfastening operation

CAUTION: Always check the direction of rotation before operation.

CAUTION: Use the reversing switch only after the tool comes to a complete stop. Changing the direction of rotation before the tool stops may damage the tool.

The tool allows you to change the direction of driver bit rotation with ease, either towards the right (clockwise) to tighten a screw or towards the left (counterclockwise) to loosen a screw.

1. Depress the reversing switch lever from the B side for counterclockwise rotation.

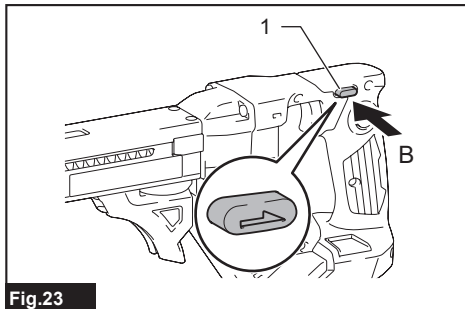

Fig.23

► 1. Reversing switch lever

2. Press and hold the release buttons on each side of the casing, and then pull the casing apart.

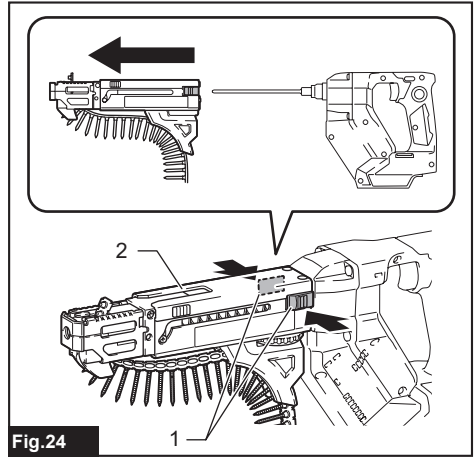

Fig.24

► 1. Release buttons 2. Casing

3. Place the tip of the driver bit into the head of the screw to be loosened.

4. Hold the tool firmly against the screw and squeeze the switch trigger to start.

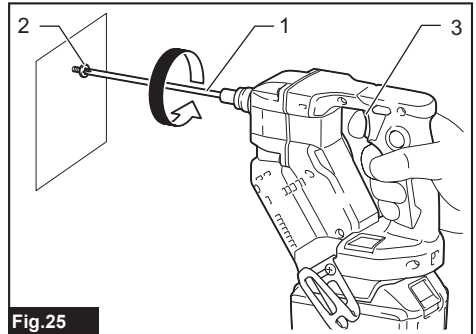

Fig.25

► 1. Driver bit 2. Screw head 3. Switch trigger

5. Reset the casing back onto the gear housing until it locks in place after finishing operation.

MAINTENANCE

CAUTION: Always be sure that the tool is switched off and the battery cartridge is removed before attempting to perform inspection or maintenance.

NOTICE: Never use gasoline, benzine, thinner, alcohol or the like. Discoloration, deformation or cracks may result.

To maintain product SAFETY and RELIABILITY, repairs, any other maintenance or adjustment should be performed by Makita Authorized or Factory Service Centers, always using Makita replacement parts.

After use

Wipe off the tool using a dry cloth or cloth slightly moistened with soapy water at regular intervals.

OPTIONAL ACCESSORIES

⚠ CAUTION: These accessories or attachments are recommended for use with your Makita tool specified in this manual. The use of any other accessories or attachments might present a risk of injury to persons. Only use accessory or attachment for its stated purpose.

If you need any assistance for more details regarding these accessories, ask your local Makita Service Center.

- Drywall screw strip
- Phillips bit
- Square bit
- Pozidriv bit
- Feeder box
- Casing
- Makita genuine battery and charger

NOTE: Some items in the list may be included in the tool package as standard accessories. They may differ from country to country.

Makita Europe N.V. Jan-Baptist Vinkstraat 2,
3070 Kortenberg, Belgium

Makita Corporation 3-11-8, Sumiyoshi-cho,
Anjo, Aichi 446-8502 Japan

www.makita.com

885905B229 EN 20210928
