

INSTRUCTION MANUAL

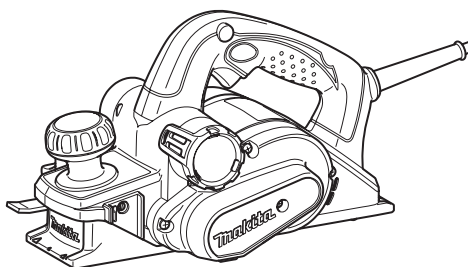

Power Planer

KP0810
KP0810C



DOUBLE INSULATION



Read before use.

SPECIFICATIONS

Model	KP0810	KP0810C
Planing width	82 mm	
Planing depth	4 mm	
Shiplapping depth	25 mm	
No load speed (min ⁻¹)	16,000	12,000
Overall length	290 mm	
Net weight	3.3 kg	3.4 kg
Safety class	□/II	

- Due to our continuing program of research and development, the specifications herein are subject to change without notice.
- Specifications may differ from country to country.
- Weight according to EPTA-Procedure 01/2014

Symbols

The followings show the symbols used for the equipment. Be sure that you understand their meaning before use.



Read instruction manual.



DOUBLE INSULATION



Only for EU countries
Do not dispose of electric equipment together with household waste material! In observance of the European Directive, on Waste Electric and Electronic Equipment and its implementation in accordance with national law, electric equipment that have reached the end of their life must be collected separately and returned to an environmentally compatible recycling facility.

Intended use

The tool is intended for planing wood.

Power supply

The tool should be connected only to a power supply of the same voltage as indicated on the nameplate, and can only be operated on single-phase AC supply. They are double-insulated and can, therefore, also be used from sockets without earth wire.

Noise

The typical A-weighted noise level determined according to EN62841-2-14:

Model KP0810

Sound pressure level (L_{pA}): 86 dB(A)

Sound power level (L_{WA}): 97 dB (A)

Uncertainty (K): 3 dB(A)

Model KP0810C

Sound pressure level (L_{pA}): 85 dB(A)

Sound power level (L_{WA}): 96 dB (A)

Uncertainty (K): 3 dB(A)

NOTE: The declared noise emission value(s) has been measured in accordance with a standard test method and may be used for comparing one tool with another.

NOTE: The declared noise emission value(s) may also be used in a preliminary assessment of exposure.

⚠ WARNING: Wear ear protection.

⚠ WARNING: The noise emission during actual use of the power tool can differ from the declared value(s) depending on the ways in which the tool is used especially what kind of workpiece is processed.

⚠ WARNING: Be sure to identify safety measures to protect the operator that are based on an estimation of exposure in the actual conditions of use (taking account of all parts of the operating cycle such as the times when the tool is switched off and when it is running idle in addition to the trigger time).

Vibration

The vibration total value (tri-axial vector sum) determined according to EN62841-2-14:

Model KP0810

Work mode: planing softwood

Vibration emission (a_h): 3.0 m/s²

Uncertainty (K): 1.5 m/s²

Model KP0810C

Work mode: planing softwood

Vibration emission (a_h): 3.5 m/s²

Uncertainty (K): 1.5 m/s²

NOTE: The declared vibration total value(s) has been measured in accordance with a standard test method and may be used for comparing one tool with another.

NOTE: The declared vibration total value(s) may also be used in a preliminary assessment of exposure.

⚠️WARNING: The vibration emission during actual use of the power tool can differ from the declared value(s) depending on the ways in which the tool is used especially what kind of workpiece is processed.

⚠️WARNING: Be sure to identify safety measures to protect the operator that are based on an estimation of exposure in the actual conditions of use (taking account of all parts of the operating cycle such as the times when the tool is switched off and when it is running idle in addition to the trigger time).

EC Declaration of Conformity

For European countries only

The EC declaration of conformity is included as Annex A to this instruction manual.

General power tool safety warnings

⚠️WARNING: Read all safety warnings, instructions, illustrations and specifications provided with this power tool. Failure to follow all instructions listed below may result in electric shock, fire and/or serious injury.

Save all warnings and instructions for future reference.

The term "power tool" in the warnings refers to your mains-operated (corded) power tool or battery-operated (cordless) power tool.

Work area safety

1. **Keep work area clean and well lit.** Cluttered or dark areas invite accidents.
2. **Do not operate power tools in explosive atmospheres, such as in the presence of flammable liquids, gases or dust.** Power tools create sparks which may ignite the dust or fumes.
3. **Keep children and bystanders away while operating a power tool.** Distractions can cause you to lose control.

Electrical safety

1. **Power tool plugs must match the outlet. Never modify the plug in any way. Do not use any adapter plugs with earthed (grounded) power tools.** Unmodified plugs and matching outlets will reduce risk of electric shock.
2. **Avoid body contact with earthed or grounded surfaces, such as pipes, radiators, ranges and refrigerators.** There is an increased risk of electric shock if your body is earthed or grounded.
3. **Do not expose power tools to rain or wet conditions.** Water entering a power tool will increase the risk of electric shock.
4. **Do not abuse the cord. Never use the cord for carrying, pulling or unplugging the power tool. Keep cord away from heat, oil, sharp edges or moving parts.** Damaged or entangled cords increase the risk of electric shock.
5. **When operating a power tool outdoors, use an extension cord suitable for outdoor use.** Use of a cord suitable for outdoor use reduces the risk of electric shock.

6. **If operating a power tool in a damp location is unavoidable, use a residual current device (RCD) protected supply.** Use of an RCD reduces the risk of electric shock.
7. **Use of power supply via an RCD with a rated residual current of 30 mA or less is always recommended.**
8. **Power tools can produce electromagnetic fields (EMF) that are not harmful to the user.** However, users of pacemakers and other similar medical devices should contact the maker of their device and/or doctor for advice before operating this power tool.
9. **Do not touch the power plug with wet hands.**
10. **If the cord is damaged, have it replaced by the manufacturer or his agent in order to avoid a safety hazard.**

Personal safety

1. **Stay alert, watch what you are doing and use common sense when operating a power tool. Do not use a power tool while you are tired or under the influence of drugs, alcohol or medication.** A moment of inattention while operating power tools may result in serious personal injury.
2. **Use personal protective equipment. Always wear eye protection.** Protective equipment such as a dust mask, non-skid safety shoes, hard hat or hearing protection used for appropriate conditions will reduce personal injuries.
3. **Prevent unintentional starting. Ensure the switch is in the off-position before connecting to power source and/or battery pack, picking up or carrying the tool.** Carrying power tools with your finger on the switch or energising power tools that have the switch on invites accidents.
4. **Remove any adjusting key or wrench before turning the power tool on.** A wrench or a key left attached to a rotating part of the power tool may result in personal injury.
5. **Do not overreach. Keep proper footing and balance at all times.** This enables better control of the power tool in unexpected situations.
6. **Dress properly. Do not wear loose clothing or jewellery. Keep your hair and clothing away from moving parts.** Loose clothes, jewellery or long hair can be caught in moving parts.
7. **If devices are provided for the connection of dust extraction and collection facilities, ensure these are connected and properly used.** Use of dust collection can reduce dust-related hazards.
8. **Do not let familiarity gained from frequent use of tools allow you to become complacent and ignore tool safety principles.** A careless action can cause severe injury within a fraction of a second.
9. **Always wear protective goggles to protect your eyes from injury when using power tools. The goggles must comply with ANSI Z87.1 in the USA, EN 166 in Europe, or AS/NZS 1336 in Australia/New Zealand. In Australia/New Zealand, it is legally required to wear a face shield to protect your face, too.**

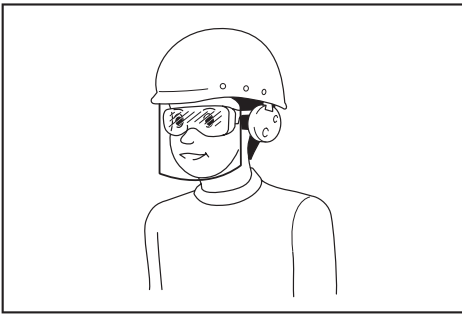

It is an employer's responsibility to enforce the use of appropriate safety protective equipments by the tool operators and by other persons in the immediate working area.

Power tool use and care

1. **Do not force the power tool. Use the correct power tool for your application.** The correct power tool will do the job better and safer at the rate for which it was designed.
2. **Do not use the power tool if the switch does not turn it on and off.** Any power tool that cannot be controlled with the switch is dangerous and must be repaired.
3. **Disconnect the plug from the power source and/or remove the battery pack, if detachable, from the power tool before making any adjustments, changing accessories, or storing power tools.** Such preventive safety measures reduce the risk of starting the power tool accidentally.
4. **Store idle power tools out of the reach of children and do not allow persons unfamiliar with the power tool or these instructions to operate the power tool.** Power tools are dangerous in the hands of untrained users.
5. **Maintain power tools and accessories. Check for misalignment or binding of moving parts, breakage of parts and any other condition that may affect the power tool's operation. If damaged, have the power tool repaired before use.** Many accidents are caused by poorly maintained power tools.
6. **Keep cutting tools sharp and clean.** Properly maintained cutting tools with sharp cutting edges are less likely to bind and are easier to control.
7. **Use the power tool, accessories and tool bits etc. in accordance with these instructions, taking into account the working conditions and the work to be performed.** Use of the power tool for operations different from those intended could result in a hazardous situation.
8. **Keep handles and grasping surfaces dry, clean and free from oil and grease.** Slippery handles and grasping surfaces do not allow for safe handling and control of the tool in unexpected situations.
9. **When using the tool, do not wear cloth work gloves which may be entangled.** The entanglement of cloth work gloves in the moving parts may result in personal injury.

Service

1. **Have your power tool serviced by a qualified repair person using only identical replacement parts.** This will ensure that the safety of the power tool is maintained.
2. **Follow instruction for lubricating and changing accessories.**

Planer Safety Warnings

1. **Wait for the cutter to stop before setting the tool down.** An exposed rotating cutter may engage the surface leading to possible loss of control and serious injury.
2. **Hold the power tool by insulated gripping surfaces, because the cutter may contact its own cord.** Cutting a "live" wire may make exposed metal parts of the power tool "live" and could give the operator an electric shock.
3. **Use clamps or another practical way to secure and support the workpiece to a stable platform.** Holding the workpiece by your hand or against the body leaves it unstable and may lead to loss of control.
4. **Rags, cloth, cord, string and the like should never be left around the work area.**
5. **Avoid cutting nails. Inspect for and remove all nails from the workpiece before operation.**
6. **Use only sharp blades. Handle the blades very carefully.**
7. **Be sure the blade installation bolts are securely tightened before operation.**
8. **Hold the tool firmly with both hands.**
9. **Keep hands away from rotating parts.**
10. **Before using the tool on an actual workpiece, let it run for a while. Watch for vibration or wobbling that could indicate poor installation or a poorly balanced blade.**
11. **Make sure the blade is not contacting the workpiece before the switch is turned on.**
12. **Wait until the blade attains full speed before cutting.**
13. **Always switch off and wait for the blades to come to a complete stop before any adjusting.**
14. **Never stick your finger into the chip chute. Chute may jam when cutting damp wood. Clean out chips with a stick.**
15. **Do not leave the tool running. Operate the tool only when hand-held.**
16. **Always change both blades or covers on the drum, otherwise the resulting imbalance will cause vibration and shorten tool life.**
17. **Use only Makita blades specified in this manual.**
18. **Always use the correct dust mask/respirator for the material and application you are working with.**

SAVE THESE INSTRUCTIONS.

⚠ WARNING: DO NOT let comfort or familiarity with product (gained from repeated use) replace strict adherence to safety rules for the subject product. MISUSE or failure to follow the safety rules stated in this instruction manual may cause serious personal injury.

FUNCTIONAL DESCRIPTION

⚠ CAUTION:

- Always be sure that the tool is switched off and unplugged before adjusting or checking function on the tool.

Adjusting depth of cut

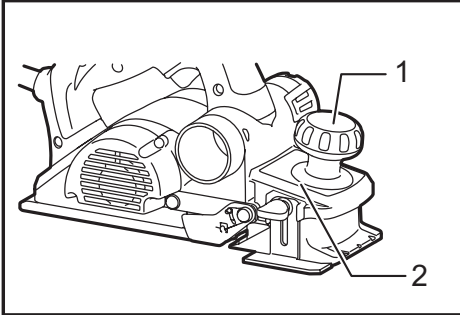

► 1. Knob 2. Pointer

Depth of cut may be adjusted by simply turning the knob on the front of the tool so that the pointer points the desired depth of cut.

Switch action

⚠ CAUTION:

- Before plugging in the tool, always check to see that the switch trigger actuates properly and returns to the "OFF" position when released.

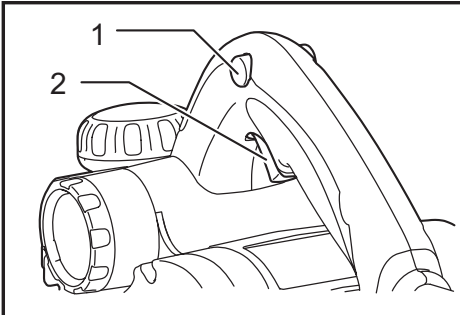

► 1. Lock button / Lock-off button 2. Switch trigger

For tool with lock button

To start the tool, simply pull the switch trigger. Release the switch trigger to stop.

For continuous operation, pull the switch trigger and then push in the lock button from either side.

To stop the tool from the locked position, pull the switch trigger fully, then release it.

For tool with lock-off button

To prevent the switch trigger from being accidentally pulled, a lock-off button is provided.

To start the tool, depress the lock-off button from either side and pull the switch trigger. Release the switch trigger to stop.

Electronic function

For Model KP0810C only

The tool equipped with electronic function are easy to operate because of the following features.

Constant speed control

Electronic speed control for obtaining constant speed. Possible to get fine finish, because the rotating speed is kept constant even under load condition.

Soft start

Soft-start feature minimizes start-up shock, and makes the tool start smoothly.

Foot

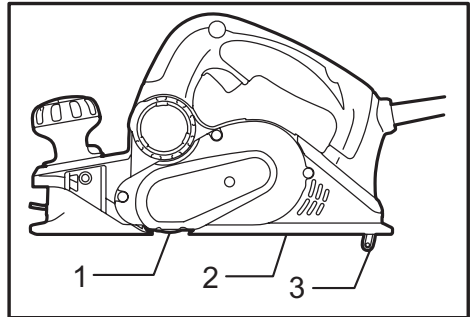

► 1. Planer blade 2. Rear base 3. Foot

After a cutting operation, raise the back side of the tool and a foot comes under the level of the rear base. This prevents the tool blades to be damaged.

ASSEMBLY

⚠ CAUTION:

- Always be sure that the tool is switched off and unplugged before carrying out any work on the tool.

Removing or installing planer blades

⚠ CAUTION:

- Tighten the blade installation bolts carefully when attaching the blades to the tool. A loose installation bolt can be dangerous. Always check to see they are tightened securely.
- Handle the blades very carefully. Use gloves or rags to protect your fingers or hands when removing or installing the blades.
- Use only the Makita wrench provided to remove or install the blades. Failure to do so may result in overtightening or insufficient tightening of the installation bolts. This could cause an injury.

For tool with standard planer blades

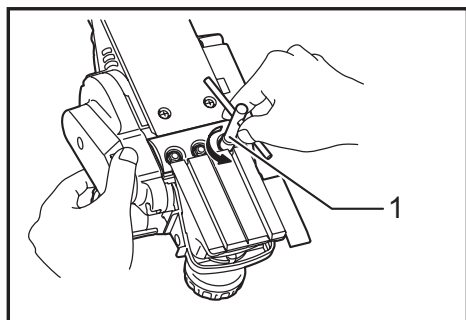

- 1. Socket wrench

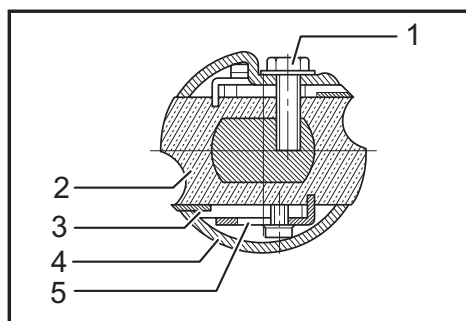

- 1. Bolt 2. Drum 3. Planer blade 4. Drum cover
5. Adjusting plate

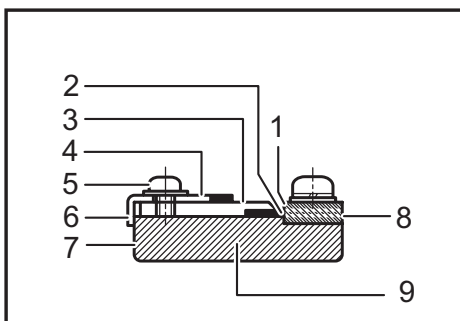

- 1. Inside edge of gauge plate 2. Blade edge
3. Planer blade 4. Adjusting plate 5. Screws
6. Heel 7. Back side of gauge base 8. Gauge plate
9. Gauge base

To remove the blades on the drum, unscrew the installation bolts with the socket wrench. The drum cover comes off together with the blades.

To install the blades, first clean out all chips or foreign matter adhering to the drum or blades. Use blades of the same dimensions and weight, or drum oscillation/vibration will result, causing poor planing action and, eventually, tool breakdown.

Place the blade on the gauge base so that the blade edge is perfectly flush with the inside edge of the gauge plate. Place the adjusting plate on the blade, then simply press in the heel of the adjusting plate flush with the back side of the gauge base and tighten two screws on the adjusting plate. Now slip the heel of the adjusting plate into the drum groove, then fit the drum cover on it. Tighten all the installation bolts evenly and alternately with the socket wrench.

For tool with mini planer blades

1. Remove the existing blade, if the tool has been in use, carefully clean the drum surfaces and the drum cover. To remove the blades on the drum, unscrew the three installation bolts with the socket wrench. The drum cover comes off together with the blades.

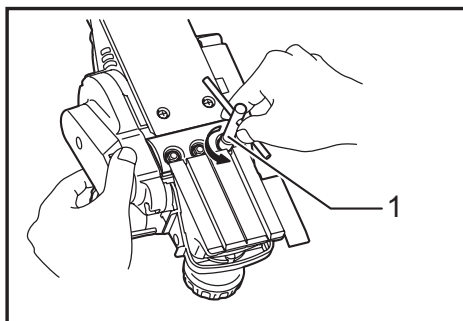

- 1. Socket wrench

- To install the blades, loosely attach the adjusting plate to the set plate with the pan head screws and set the mini planer blade on the gauge base so that the cutting edge of the blade is perfectly flush with the inside flank of the gauge plate.

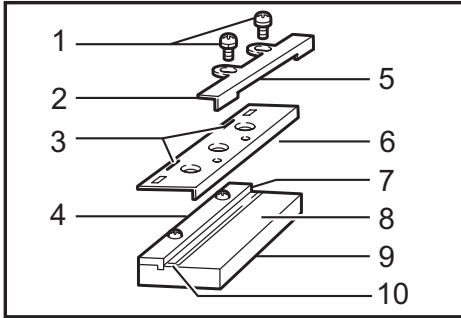

- 1. Pan head screw 2. Adjusting plate 3. Planer blade locating lugs 4. Gauge plate 5. Heel of adjusting plate 6. Set plate 7. Inside flank of gauge plate 8. Gauge base 9. Back side of gauge base 10. Mini planer blade

- Set the adjusting plate/set plate on the gauge base so that the planer blade locating lugs on the set plate rest in the mini planer blade groove, then press in the heel of the adjusting plate flush with the back side of the gauge base and tighten the pan head screws.
- It is important that the blade sits flush with the inside flank of the gauge plate, the planer blade locating lugs sit in the blade groove and the heel of the adjusting plate is flush with the back side of the gauge base. Check this alignment carefully to ensure uniform cutting.
- Slip the heel of the adjusting plate into the groove of the drum.
- Set the drum cover over the adjusting plate/set plate and screw in the three hex flange head bolts so that a gap exists between the drum and the set plate to slide the mini planer blade into position. The blade will be positioned by the planer blade locating lugs on the set plate.

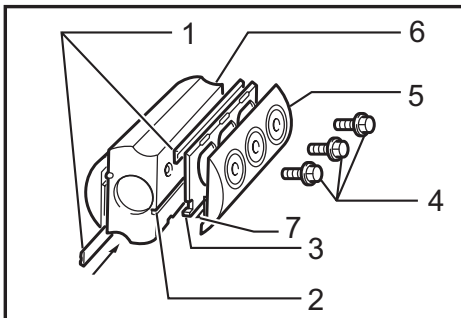

- 1. Mini planer blade 2. Groove 3. Set plate 4. Hex. flange head bolts 5. Drum cover 6. Drum 7. Adjusting plate

- The blade's lengthwise adjustment will need to be manually positioned so that the blade ends are clear and equidistant from the housing on one side and the metal bracket on the other.
- Tighten the three hex flange head bolts (with the socket wrench provided) and rotate the drum to check clearances between the blade ends and the tool body.
- Check the three hex flange head bolts for final tightness.
- Repeat procedures 1 - 9 for other blade.

For the correct planer blade setting

Your planing surface will end up rough and uneven, unless the blade is set properly and securely. The blade must be mounted so that the cutting edge is absolutely level, that is, parallel to the surface of the rear base. Refer to some examples below for proper and improper settings.

- (A) Front base (Movable shoe)
- (B) Rear base (Stationary shoe)

Correct setting

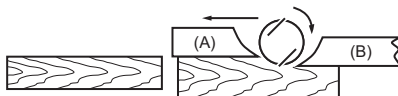

Although this side view cannot show it, the edges of the blades run perfectly parallel to the rear base surface.

Nicks in surface

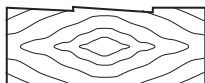

Cause: One or both blades fails to have edge parallel to rear base line.

Gouging at start

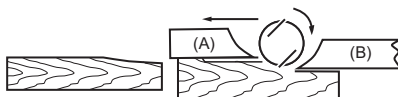

Cause: One or both blade edges fails to protrude enough in relation to rear base line.

Gouging at end

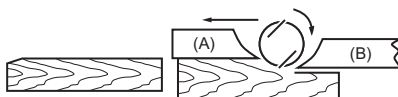

Cause: One or both blade edges protrudes too far in relation to rear base line.

Change of chip discharge direction

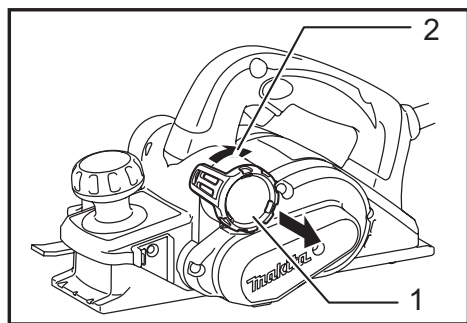

► 1. Stopper 2. Chip discharge opening

Chip discharge direction can be changed to the right or left. To change the direction, pull out the stopper while turning it slightly backward and fit it in one of two openings on the opposite side of chip discharge so that the recessed part fits to protrusion.

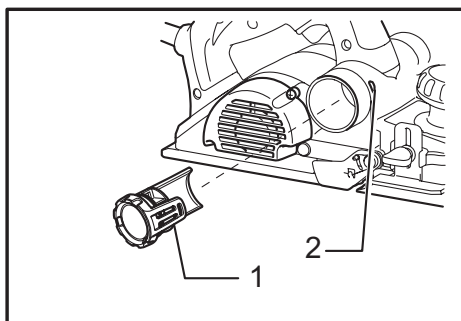

► 1. Recessed part 2. Protrusion

Dust bag (accessory)

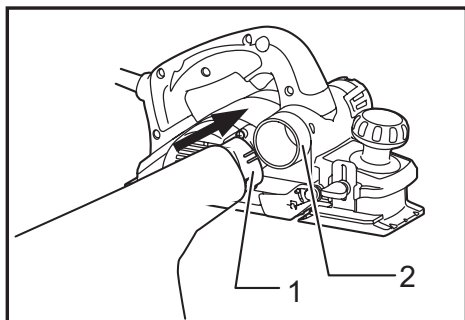

► 1. Dust bag 2. Chip discharge opening

Attach the dust bag onto the chip discharge opening. The chip discharge opening is tapered. When attaching the dust bag, push it onto the chip discharge opening firmly as far as it will go to prevent it from coming off during operation. When the dust bag is about half full, remove the dust bag from the tool and pull the fastener out. Empty the dust bag of its contents, tapping it lightly so as to remove particles adhering to the insides which might hamper further collection.

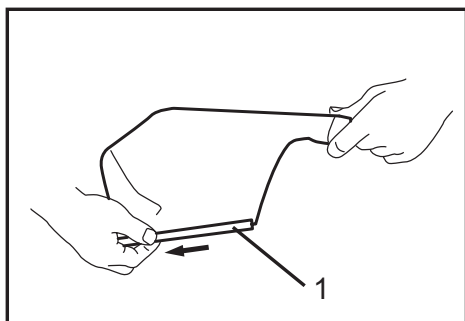

► 1. Fastener

NOTE:

- If you connect a Makita vacuum cleaner to this tool, more efficient and cleaner operations can be performed.

Connecting a vacuum cleaner

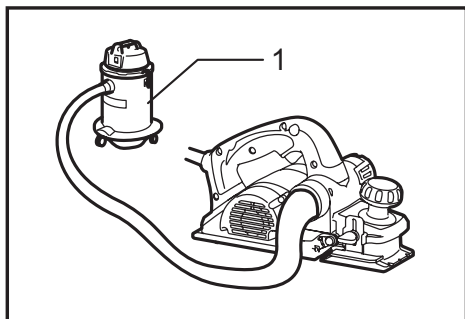

► 1. Vacuum cleaner

When you wish to perform clean planing operation, connect a Makita vacuum cleaner to your tool. Then connect a hose of the vacuum cleaner to the chip discharge opening as shown in the figures.

Elbow (optional accessory)

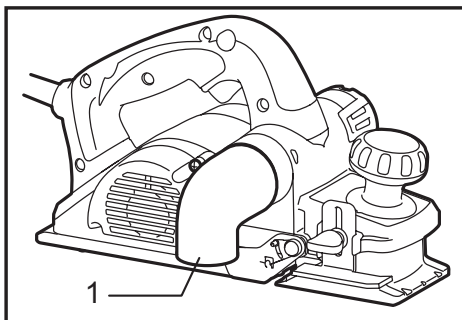

► 1. Elbow

Use of elbow allows change of chip discharge direction to perform cleaner work.

Install the elbow (optional accessory) on the tool by just slipping on it. To remove it, just pull it out.

Chip discharge opening cleaning

Clean the chip discharge opening regularly. Use a compressed air to clean the clogged chip discharge opening.

OPERATION

Hold the tool firmly with one hand on the knob and the other hand on the switch handle when performing the tool.

Planing operation

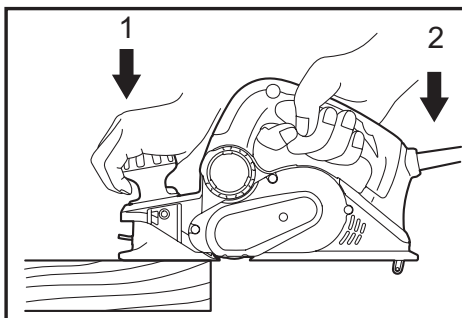

► 1. Start 2. End

First, rest the tool front base flat upon the workpiece surface without the blades making any contact. Switch on and wait until the blades attain full speed. Then move the tool gently forward. Apply pressure on the front of tool at the start of planing, and at the back at the end of planing. Planing will be easier if you incline the workpiece in stationary fashion, so that you can plane somewhat downhill.

The speed and depth of cut determine the kind of finish. The power planer keeps cutting at a speed that will not result in jamming by chips. For rough cutting, the depth of cut can be increased, while for a good finish you should reduce the depth of cut and advance the tool more slowly.

Shiplapping (Rabbeting)

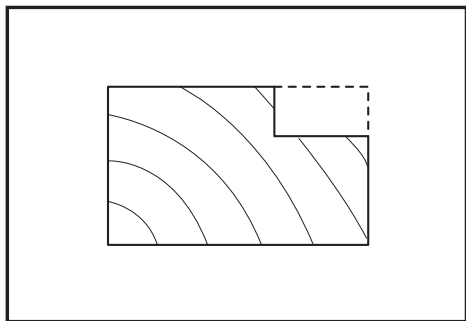

To make a stepped cut as shown in the figure, use the edge fence (guide rule). Adjust the shiplapping depth using a depth guide (accessory). Draw a cutting line on the workpiece. Insert the edge fence into the hole in the front of the tool. Align the blade edge with the cutting line.

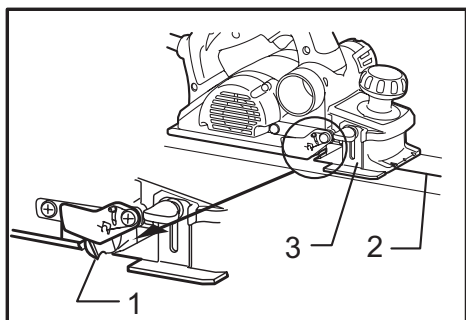

► 1. Blade edge 2. Cutting line 3. Depth guide

Install the edge fence on the tool and secure it with the washer and thumb screw (A). Loosen the thumb screw (B) and adjust the edge fence until it comes in contact with the side of the workpiece. Then tighten the thumb screw (B) securely.

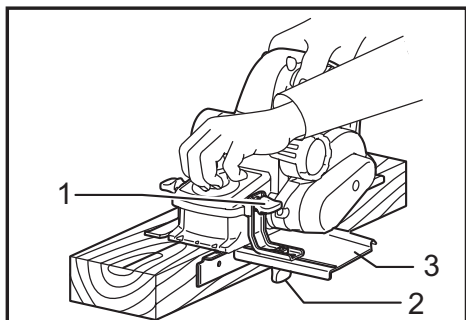

► 1. Screw (A) 2. Screw (B) 3. Edge fence

When planing, move the tool with the edge fence flush with the side of the workpiece. Otherwise uneven planing may result.

CAUTION:

- The blade edge should be made to protrude outside slightly (0.2 mm - 0.4 mm) for shiplapping.

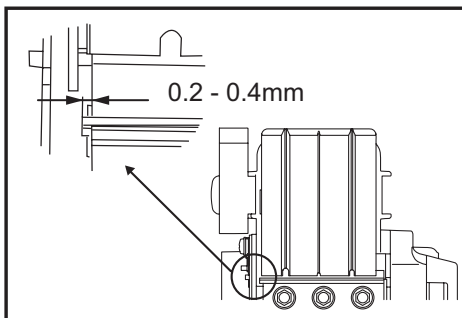

You may wish to add to the length of the fence by attaching an extra piece of wood. Convenient holes are provided in the fence for this purpose, and also for attaching an extension guide (optional accessory).

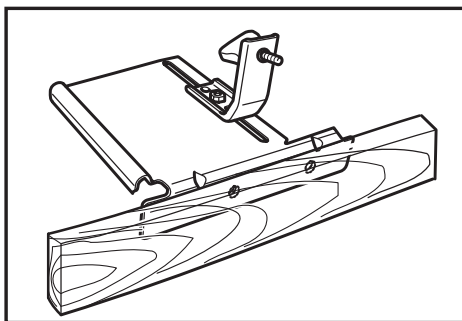

Chamfering

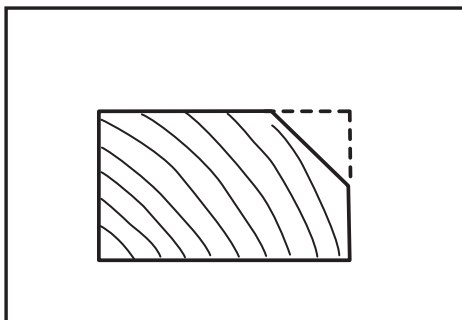

To make a chamfering cut as shown in the figure, align one of three "V" grooves in the front base with the edge of the workpiece and plane it.

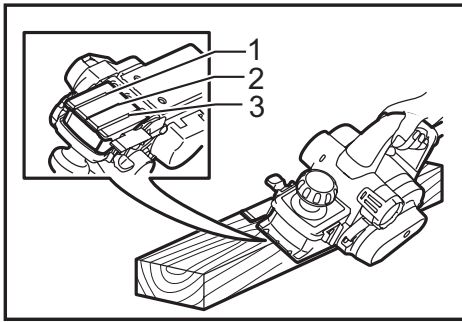

- 1. V groove (medium amount of chamfering) 2. V groove (small amount of chamfering) 3. V groove (great amount of chamfering)

Use of chamfering rule (optional accessory) assures more tool stability when shiplapping.

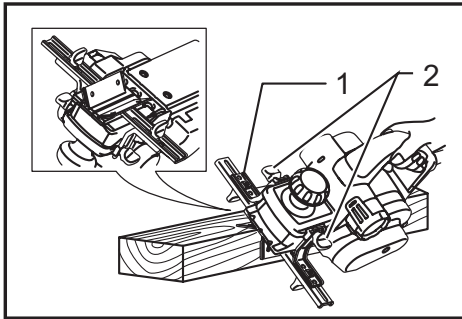

- 1. Chamfering rule 2. Screws

To install the chamfering rule, remove two screws on both sides of the front of the tool and set the depth of cut to 4 mm. And then install it on the front base of the tool and secure it the screws as shown in the figure. When doing a great amount of chamfering, place an edge of chamfering rule so that it contacts workpiece and make many passes of planing as shown in the figure.

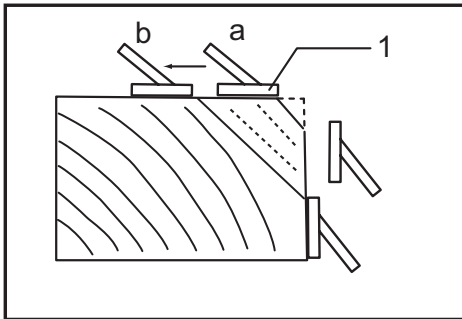

- 1. Edge of chamfering rule

MAINTENANCE

▲ CAUTION:

- Always be sure that the tool is switched off and unplugged before attempting to perform inspection or maintenance.
- Never use gasoline, benzine, thinner, alcohol or the like. Discoloration, deformation or cracks may result.

To maintain product SAFETY and RELIABILITY, repairs, carbon brush inspection and replacement, any other maintenance or adjustment should be performed by Makita Authorized or Factory Service Centers, always using Makita replacement parts.

Sharpening the planer blades

For standard blades only

Always keep your blades sharp for the best performance possible. Use the sharpening holder to remove nicks and produce a fine edge.

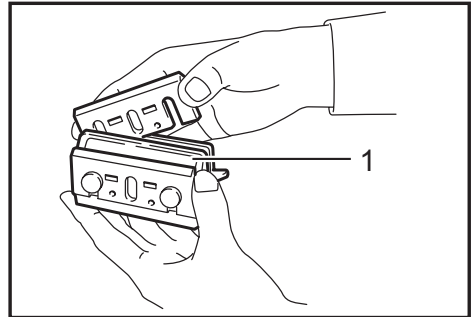

- 1. Sharpening holder

First, loosen the two wing nuts on the holder and insert the blades (A) and (B), so that they contact the sides (C) and (D). Then tighten the wing nuts.

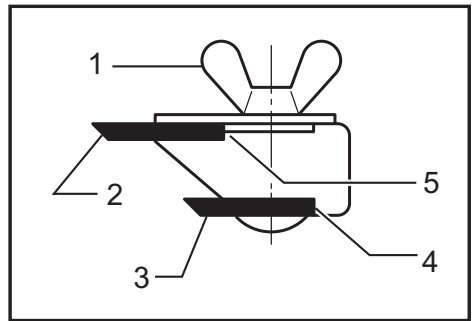

- 1. Wing nut 2. Blade (A) 3. Blade (B) 4. Side (D) 5. Side (C)

Immerse the dressing stone in water for 2 or 3 minutes before sharpening. Hold the holder so that the both blades contact the dressing stone for simultaneous sharpening at the same angle.

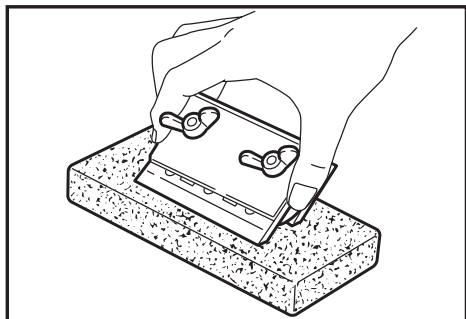

OPTIONAL ACCESSORIES

CAUTION:

- These accessories or attachments are recommended for use with your Makita tool specified in this manual. The use of any other accessories or attachments might present a risk of injury to persons. Only use accessory or attachment for its stated purpose.

If you need any assistance for more details regarding these accessories, ask your local Makita Service Center.

- High-speed steel Planer blade
- Tungsten-carbide Planer blade (For longer blade life)
- Mini planer blade
- Sharpening holder assembly
- Blade gauge
- Set plate set
- Edge fence (Guide rule)
- Dressing stone
- Dust bag assembly
- Elbow
- Socket wrench
- Chamfering rule assembly

NOTE:

- Some items in the list may be included in the tool package as standard accessories. They may differ from country to country.

Makita Europe N.V. Jan-Baptist Vinkstraat 2,
3070 Kortenberg, Belgium

Makita Corporation 3-11-8, Sumiyoshi-cho,
Anjo, Aichi 446-8502 Japan

www.makita.com

884693I225
EN
20190327