

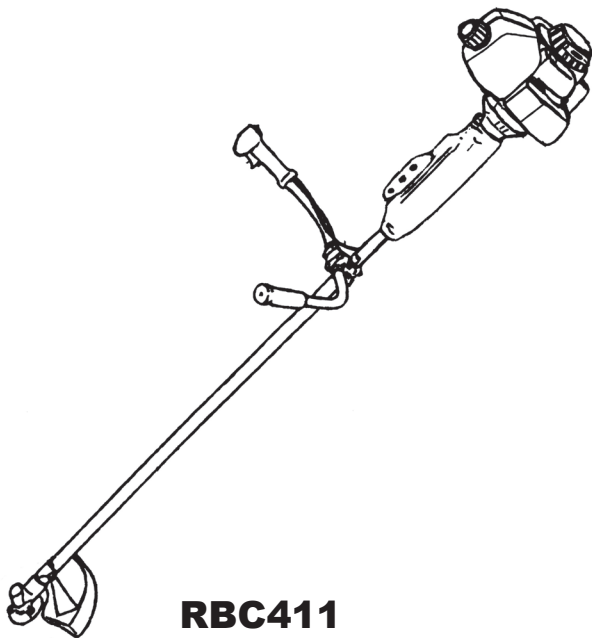

Petrol Brushcutter

RBC411
RBC411U

INSTRUCTION MANUAL



RBC411

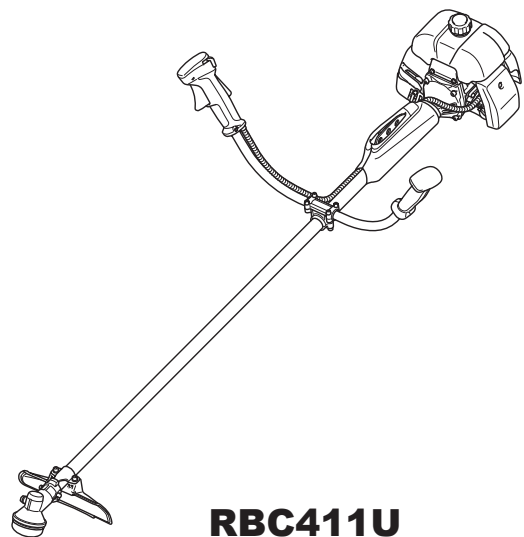

RBC411U

Important:

Read this instruction manual carefully before putting the brushcutter into operation and strictly observe the safety regulations!

Preserve instruction manual carefully!

Thank you very much for selecting the MAKITA brushcutter. We are pleased to be able to offer you the MAKITA brushcutter which is the result of a long development programme and many years of knowledge and experience. Please read, understand and follow this booklet which refers in detail to the various points that will demonstrate its outstanding performance. This will assist you to obtain the best possible result from your MAKITA brushcutter.



Table of Contents

Page

Symbols.....	2
Safety instructions	3
Technical data	7
Designation of parts.....	8
Assembly of engine and shaft	9
Mounting of handle	9
Mounting of protector.....	10
Mounting of cutter blade	12
Fuels/refueling	14
Correct handling of machine.....	15
Putting into operation.....	16
Resharpener the cutting tool.....	17
Maintenance schedule.....	18
Storage.....	19

SYMBOLS

You will note the following symbols when reading the instruction manual.

	Read instruction manual		Keep the area of operation clear of all persons and pets
	Take particular care and attention		Wear protective helmet, eye and ear protection
	Forbidden		Top permissible tool speed
	Keep distance		Fuel and oil mixture
	Flying object hazard		Engine-Manual start
	No smoking		Emergency stop
	No open flame		First Aid
	Protective gloves must be worn		ON/START
	Wear sturdy boots with non-slip soles. Steel toed safety boots are recommended.		OFF/STOP
	Kickback		

SAFETY INSTRUCTIONS

General Instructions

- Read this instruction manual to become familiar with handling of the equipment. Users insufficiently informed will risk danger to themselves as well as others due to improper handling.
- It is recommended only to lend the equipment to people who have proven to be experienced.
Always hand over the instruction manual.
- First users should ask the dealer for basic instructions to familiarize oneself with the handling of brushcutters.
- Children and young persons aged under 18 years must not be allowed to operate this equipment. Persons over the age of 16 years may however use the device for the purpose of being trained while under supervision of a qualified trainer.
- Use with the utmost care and attention.
- Operate only if you are in good physical condition. Perform all work calmly and carefully. The user has to accept liability for others.
- Never use this equipment after consumption of alcohol or drugs, or if feeling tired or ill.
- National regulation can restrict the use of the machine.

Intended use of the machine

- This equipment is only intended for cutting grass, weeds, bushes, undergrowth. It should not be used for any other purpose such as edging or hedge cutting as this may cause injury.

Personal protective equipment

- The clothing worn should be functional and appropriate, i.e. it should be tight-fitting but not cause hindrance. Do not wear either jewelry or clothing which could become entangled with bushes or shrubs.
- In order to avoid either head-, eye-, hand- or foot injuries as well as to protect your hearing the following protective equipment and protective clothing must be used during operation.
- Always wear a helmet where there is a risk of falling objects. The protective helmet (1) is to be checked at regular intervals for damage and is to be replaced at the latest after 5 years. Use only approved protective helmets.
- The visor (2) of the helmet (or alternatively goggles) protects the face from flying debris and stones. During operation always wear goggles, or a visor to prevent eye injuries.
- Wear adequate noise protection equipment to avoid hearing impairment (ear muffs (3), ear plugs etc.).
- The work overalls (4) protect against flying stones and debris. We strongly recommend that the user wears work overalls.
- Gloves (5) are part of the prescribed equipment and must always be worn during operation.
- When using the equipment, always wear sturdy shoes (6) with a non-slip sole. This protects against injuries and ensures a good footing.

Starting up the brushcutter

- Please make sure that there are no children or other people within a working range of 15 meters (50 ft), also pay attention to any animals in the working vicinity.
- Before use always check the equipment is safe for operation:
Check the security of the cutting tool, the throttle lever for easy action and check for proper functioning of the throttle lever lock.
- Rotation of the cutting tool during idling speed is not allowed. Check with your dealer for adjustment if in doubt. Check for clean and dry handles and test the function of the start/stop switch.

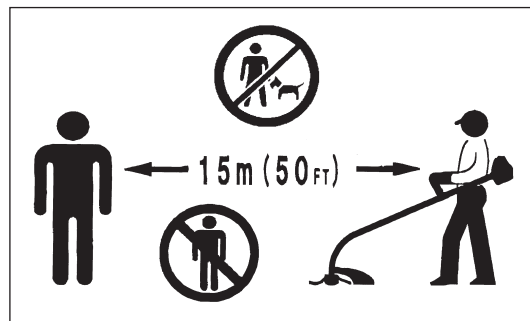
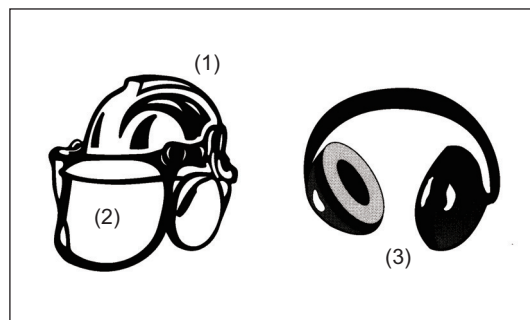
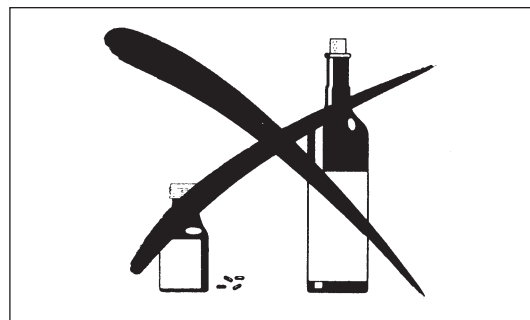
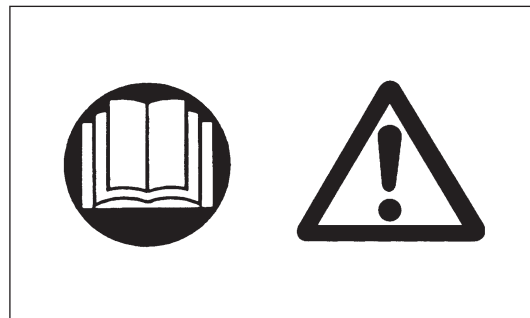

Start the brushcutter only in accordance with the instructions.

- Do not use any other methods for starting the engine!
- Use the brushcutter and the tools only for such applications as specified.
- Only start the engine, after the entire assembly is done. Operation of the device is only permitted after all the appropriate accessories are attached!
- Before starting make sure that the cutting tool has no contact with hard objects such as branches, stones etc. as the cutting tool will revolve when starting.
- The engine is to be switched off immediately in case of any engine problems.
- Should the cutting tool hit stones or other hard objects, immediately switch off the engine and inspect the cutting tool.
- Inspect the cutting tool at short regular intervals for damage (detection of hairline cracks by means of tapping-noise test).
- If the equipment gets heavy impact or fall, check the condition before continuing work. Check the fuel system for fuel leakage and the controls and safety devices for malfunction. If there is any damage or doubt, ask our authorized service center for the inspection and repair.
- Operate the equipment only with the shoulder harness attached which is to be suitably adjusted before putting the brushcutter into operation. It is essential to adjust the shoulder harness according to the user size to prevent fatigue occurring during use. Never hold the cutter with one hand during use.
- During operation always hold the brushcutter with both hands. Always ensure a safe footing.
- Operate the equipment in such a manner as to avoid inhalation of the exhaust gases. Never run the engine in enclosed rooms (risk of gas poisoning). Carbon monoxide is an odorless gas.
- Switch off the engine when resting and when leaving the equipment unattended, and place it in a safe location to prevent danger to others or damage to the machine.
- Never put the hot brushcutter onto dry grass or onto any combustible materials.
- Always install the approved cutting tool guard onto the equipment before starting the engine. Otherwise contact with the cutting tool may cause serious injury.
- All protective installations and guards supplied with the machine must be used during operation.
- Never operate the engine with faulty exhaust muffler.
- Shut off the engine during transport.
- When transporting the equipment, always attach the cover to the cutting blade.
- Ensure safe position of the equipment during car transportation to avoid fuel leakage.
- When transporting, ensure that the fuel tank is completely empty.
- When unloading the equipment from the truck, never drop the Engine to the ground or this may severely damage the fuel tank.
- Except in case of emergency, never drop or cast the equipment to the ground or this may severely damage the equipment.
- Remember to lift the entire equipment from the ground when moving the equipment. Dragging the fuel tank is highly dangerous and will cause damage and leakage of fuel, possibly causing fire.

Refueling

- Shut off the engine during refueling, keep away from open flames and do not smoke.
- Avoid skin contact with mineral oil products. Do not inhale fuel vapor. Always wear protective gloves during refueling. Change and clean protective clothing at regular intervals.
- Take care not to spill either fuel or oil in order to prevent soil contamination (environmental protection). Clean the brushcutter immediately after fuel has been spilt.
- Avoid any fuel contact with your clothing. Change your clothing instantly if fuel has been spilt on it (to prevent clothing catching fire).
- Inspect the fuel cap at regular intervals making sure that it can be securely fastened and does not leak.
- Carefully tighten the fuel tank cap. Change location to start the engine (at least 3 meters away from the place of refueling).
- Never refuel in closed rooms. Fuel vapors accumulate at ground level (risk of explosions).
- Only transport and store fuel in approved containers. Make sure the fuel stored is not accessible to children.

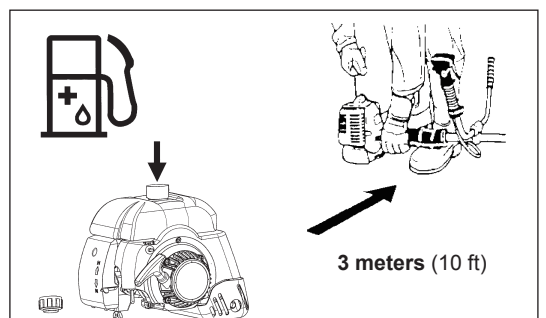
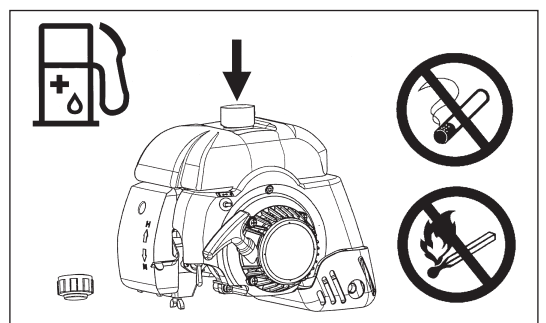
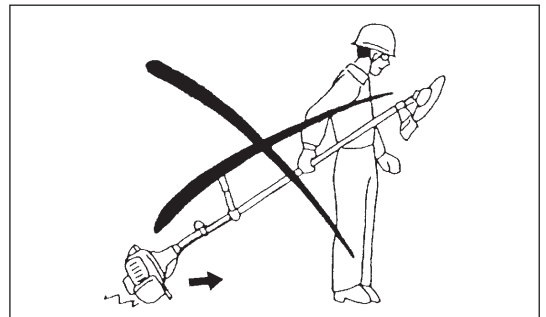
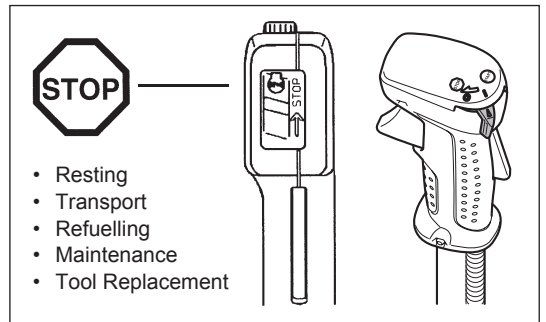
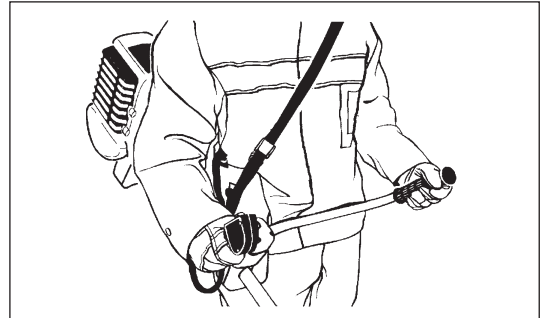
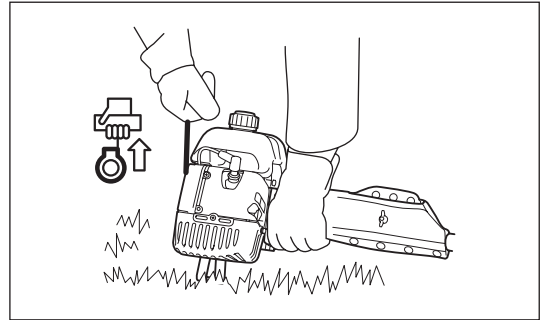

Method of operation

- Only use in good light and visibility. During the winter season beware of slippery or wet areas, ice and snow (risk of slipping). Always ensure a safe footing.
- Never cut above waist height.
- Never stand on a ladder.
- Never climb up into trees to perform cutting operation.
- Never work on unstable surfaces.
- Remove sand, stones, nails etc. found within the working range. Foreign particles may damage the cutting tool and can cause dangerous kickbacks.
- Before commencing cutting, the cutting tool must have reached full working speed.
- When using metal blades, swing the tool evenly in half-circle from right to left, like using a scythe. If grass or branches get caught between the cutting tool and guard, always stop the engine before cleaning. Otherwise unintentional blade rotation may cause serious injury.
- Take a rest to prevent loss of control caused by fatigue. We recommend to take a 10 to 20-minute rest every hour.

Cutting Tools

- Use an applicable cutting tool for the job in hand. Metal blades are suitable for cutting weeds, high grasses, bushes, shrubs, underwood, thicket, and the like. Never use other blades including metal multi-piece pivoting chains and flail blades. Otherwise serious injury may result.
- When using metal blades, avoid “kickback” and always prepare for an accidental kickback. See the section “Kickback” and “Kickback prevention.”

Kickback (blade thrust)

- Kickback (blade thrust) is a sudden reaction to a caught or bound cutting blade. Once it occurs, the equipment is thrown sideways or toward the operator at great force and it may cause serious injury.
- Kickback occurs particularly when applying the blade segment between 12 and 2 o'clock to solids, bushes and trees with 3 cm or larger diameter.
- To avoid kickback:
 - Apply the segment between 8 and 11 o'clock;
 - Never apply the segment between 12 and 2 o'clock;
 - Never apply the segment between 11 and 12 o'clock and between 2 and 5 o'clock, unless the operator is well trained and experienced and does it at his/her own risk;
 - Never use cutting blades close to solids, such as fences, walls, tree trunks and stones;
 - Never use cutting blades vertically, for such operations as edging and trimming hedges.

Vibration

- People with poor circulation who are exposed to excessive vibration may experience injury to blood vessels or the nervous system. Vibration may cause the following symptoms to occur in the fingers, hands or wrists: “Falling asleep” (numbness), tingling, pain, stabbing sensation, alteration of skin color or of the skin. If any of these symptoms occur, see a physician!
- To reduce the risk of “white finger disease”, keep your hands warm during operation and well maintain the equipment and accessories.

Maintenance instructions

- Have your equipment serviced by our authorized service center, always using only genuine replacement parts. Incorrect repair and poor maintenance can shorten the life of the equipment and increase the risk of accidents.
- The condition of the cutter, in particular of the cutting tool of the protective devices and also of the shoulder harness must be checked before commencing work. Particular attention is to be paid to the cutting blades which must be correctly sharpened.
- Turn off the engine and remove spark plug connector when replacing or sharpening cutting tools, and also when cleaning the cutter or cutting tool.

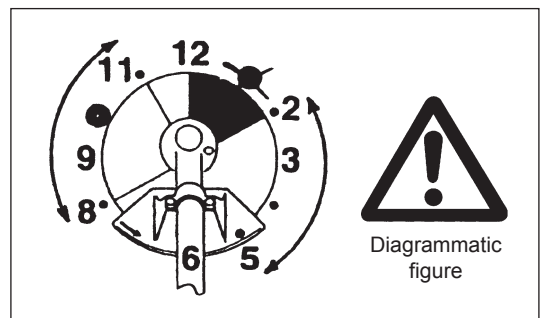
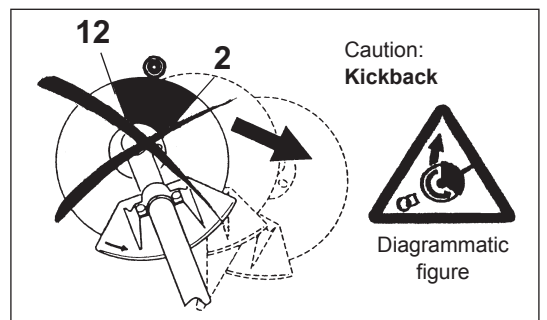
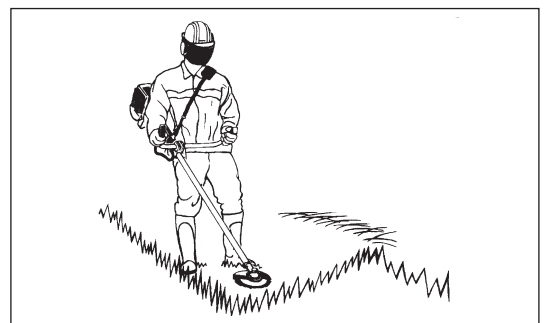

Never straighten or weld damaged cutting tools.

- Pay attention to the environment. Avoid unnecessary throttle operation for less pollution and noise emissions. Adjust the carburetor correctly.
- Clean the equipment at regular intervals and check that all screws and nuts are well tightened.
- Never service or store the equipment in the vicinity of naked flames.
- Always store the equipment in locked rooms and with an emptied fuel tank.
- When cleaning, servicing and storing the equipment, always attach the cover to the cutting blade.



Observe the relevant accident prevention instructions issued by the relevant trade associations and by the insurance companies. Do not perform any modifications to the equipment as this will endanger your safety.

The performance of maintenance or repair work by the user is limited to those activities as described in the instruction manual. All other work is to be done by an Authorized Service Agent. Use only genuine spare parts and accessories released and supplied by MAKITA. Use of non-approved accessories and tools means increased risk of accidents. MAKITA will not accept any liability for accidents or damage caused by the use of non-approved cutting tools and fixing devices of cutting tools, or accessories.

First Aid

In case of accident make sure that a first-aid box is available in the vicinity of the cutting operations. Immediately replace any item taken from the first aid box.

When asking for help, please give the following information:

- Place of accident
- What happened
- Number of injured persons
- Kind of injuries
- Your name

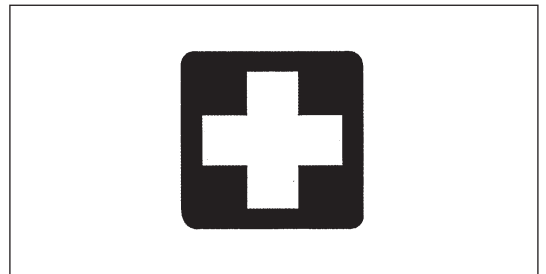

TECHNICAL DATA

Model	RBC411		RBC411U	
	U handle			
Dimensions: length x width x height (without cutting blade)	mm	1,705 x 620 x 435		1,710 x 670 x 430
Mass (without plastic guard and cutting blade)	kg	7.3		
Volume (fuel tank)	L	1.1		
Engine displacement	cm ³	40.2		
Maximum engine performance	kW	1.47 at 7,000 min ⁻¹		
Engine speed at recommended max. spindle speed	min ⁻¹	10,000		
Maximum spindle speed (corresponding)	min ⁻¹	6,800		
Fuel consumption	kg/h	0.98 (32.8 oz/h)		
Specific fuel consumption	g/kWh	1134.5 (29.9 oz/kwh)		
Idling speed	min ⁻¹	2,800		
Clutch engagement speed	min ⁻¹	3,600		
Carburetor		Float - carburetor type		
Ignition system	type	Solid state ignition		
Spark plug	type	NGK BPM7A		
Electrode gap	mm	0.6 – 0.7		
Mixture ratio (Fuel: MAKITA 2-stroke oil)		25 : 1		
Gear ratio		13/19		

1) The data takes equally into account the idling and racing or wide open throttle speed operating modes.

DESIGNATION OF PARTS

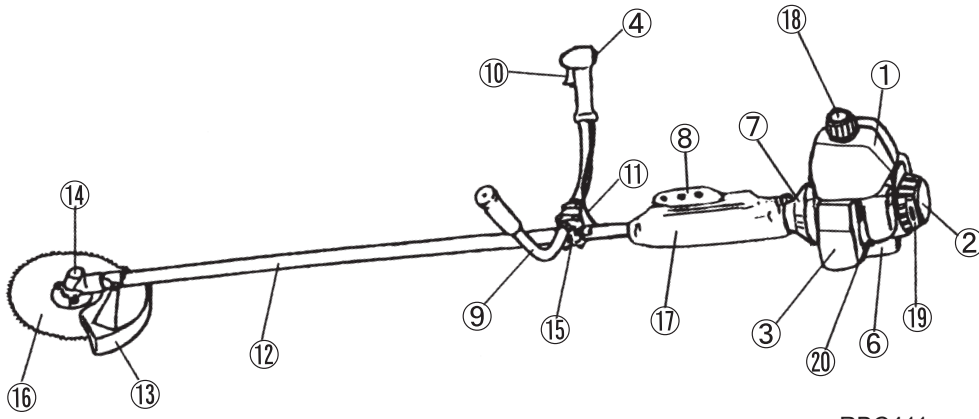

RBC411

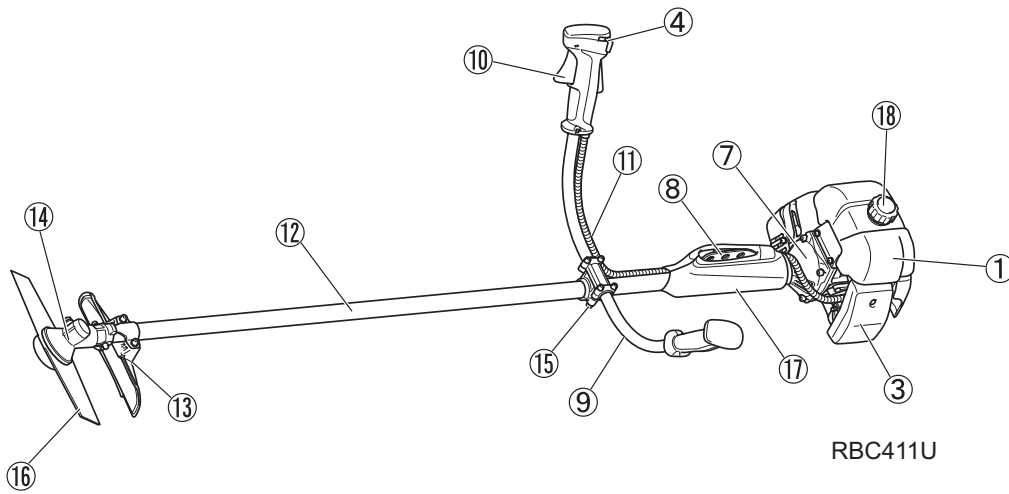

RBC411U

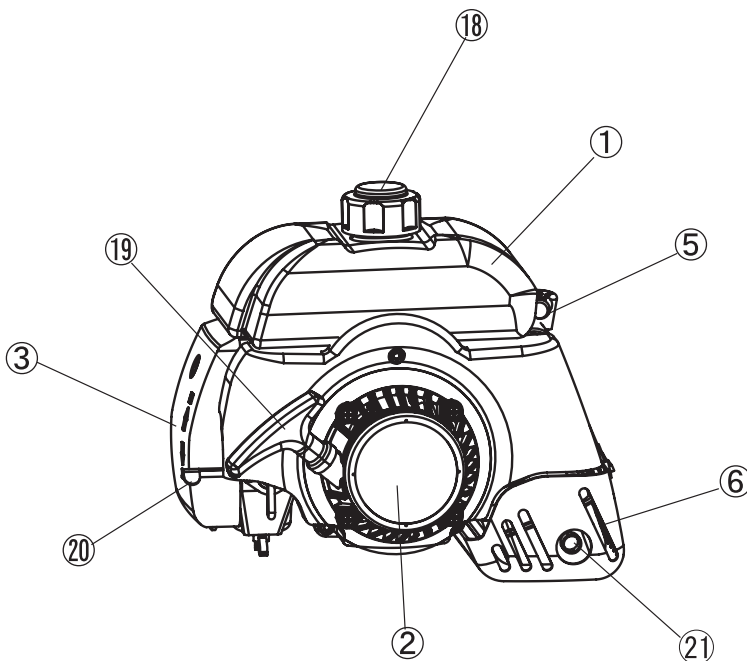

GB	DESIGNATION OF PARTS
1	Fuel Tank
2	Rewind Starter
3	Air Cleaner
4	I-O Switch (on/off)
5	Spark Plug
6	Exhaust Muffler
7	Clutch Case
8	Hanger
9	Handle
10	Throttle Lever
11	Throttle wire
12	Shaft
13	Protector
14	Gear Case
15	Handle Holder
16	Cutter Blade
17	Waist Pad
18	Fuel Filler Cap
19	Starter Knob
20	Choke Lever
21	Exhaust Pipe

ASSEMBLY OF ENGINE AND SHAFT

CAUTION: Before doing any work on the brushcutter, always switch off the motor and pull the spark plug connector off the spark plug.
Always wear protective gloves.

CAUTION: Start the brushcutter only after having assembled it completely.

- After checking the parts, fasten the drive shaft to the engine with four bolts M6 x 22 (1). At this time, fasten also the earth terminal (2) of the stop cord to the engine.

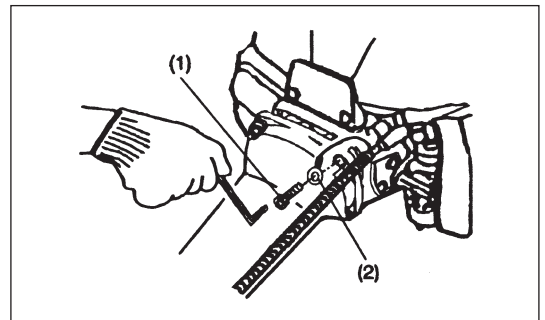

MOUNTING OF HANDLE

- Place the handle with the throttle lever on the handle holder on the right side (to be held by the right hand) and the other on the left side.
- Fit the handle edge to the handle holder groove, and provisionally fix the upper side (3) of the handle holder by four bolts M5 x 25 (4).
- Adjust the handle to an angle easy to manipulate, and tighten the bolt (4) uniformly on the right and left sides.

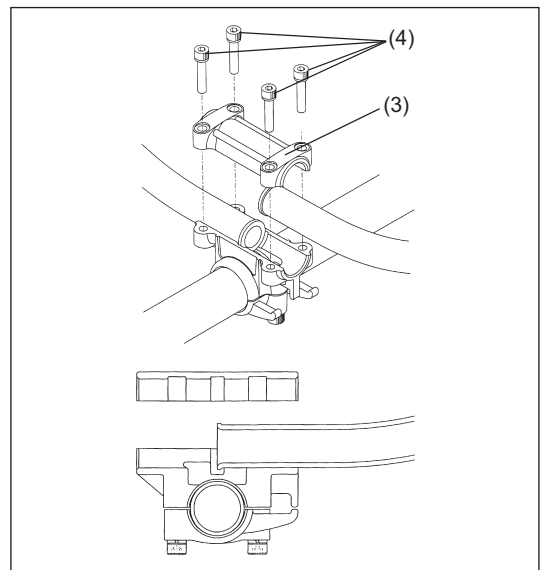

- Mount the waist pad (5). When the waist pad is mounted, be sure to confirm that the wires do not move horizontally.
- Avoid any tendency of the throttle wire to loop at the handle bar.

The purpose of the detent lock is to prevent the engine from rotating relative to the drive shaft while operating the starter or transporting the equipment from place to place. The detent should be unlocked while the unit is being used.

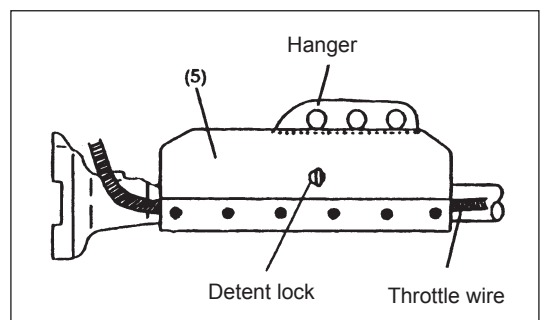

MOUNTING OF PROTECTOR

To meet the applicable safety provisions, only the tool/protector combinations as indicated in the table must be used.



Be sure to use genuine MAKITA cutter blade or nylon cutting head.

- The cutter blade must be well polished, free of cracks or breakage.
- If the cutter blade hits against a stone during operation, stop the engine and check the blade immediately.
- Polish or replace the cutter blade every three hours of operation.
- The outside diameter of the cutter blade must be 255 mm (10"). Cutter blades with outside diameter of 305 mm or 12 inches can be used only for those with two or three blades.

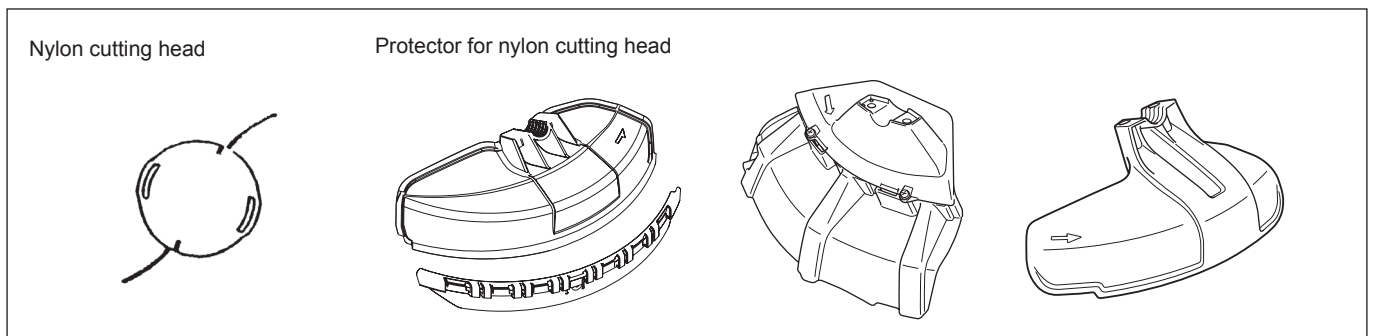
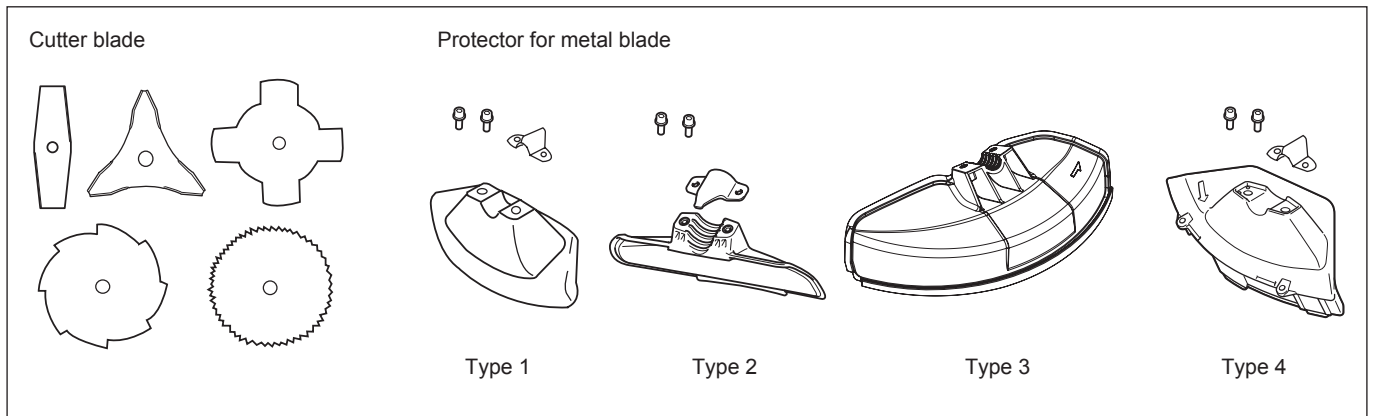

CAUTION: The appropriate protector must always be installed, for your own safety and in order to comply with accident-prevention regulations. Operation of the equipment without the guard being in place is not permitted.

Type 1, 2

- Fix the protector (1) to the clamp (3) with two bolts M6 x 30 (2).

NOTE: Tighten the right and left bolts evenly so that the gap between the clamp (3) and the protector (1) will be constant. Otherwise, the protector sometimes may not function as specified.

CAUTION: The outside diameter of the cutter blade must be 255 mm (10"). Cutter blades with outside diameter of 305 mm or 12 inches can be used only for those with two or three blades.

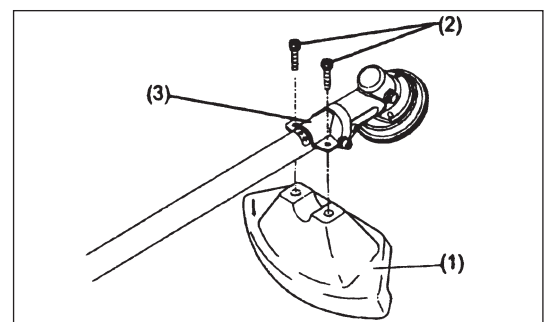

Type 3

– In use of the metal blade, fix the protector (3) to the clamp (2) with two bolts (1).

NOTE: Tighten the right and left bolts evenly so that the gap between the clamp (2) and the protector (3) will be constant. Otherwise, the protector sometimes may not function as specified.

CAUTION: The outside diameter of the cutter blade must be 255 mm (10"). Cutter blades with outside diameter of 305 mm or 12 inches can be used only for those with two or three blades.

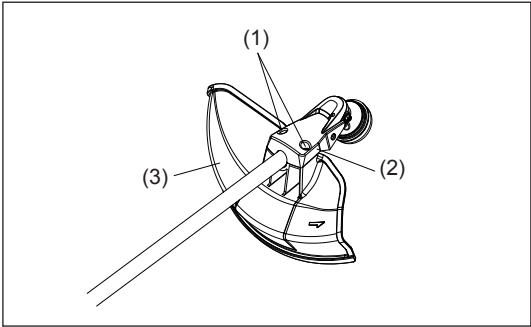

- In cases where the nylon cord cutter is to be used, be sure to mount the nylon cord cutter protector (4) onto the metal blade protector (3).
- Mount the nylon cord cutter protector (4) by sliding it into place from the flank of the metal blade protector (3) as shown.
- Remove tape adhered to cutter, which cuts nylon cord, on nylon cord cutter protector (4).

CAUTION: Be sure to push in nylon cord cutter protector (4) until it is fully inserted. Take care not to injure yourself on the cutter for cutting the nylon cord.

- To remove the nylon cord cutter protector (4), apply a hex wrench into the notch on the metal blade protector (3), push it in and meanwhile slide the nylon cord cutter protector (4).

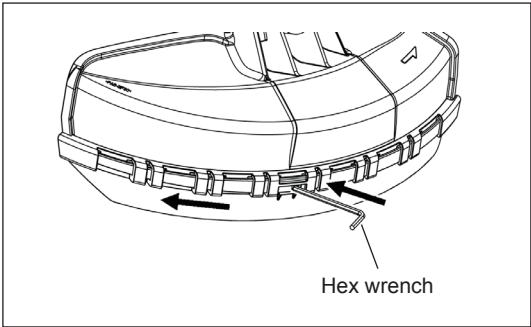
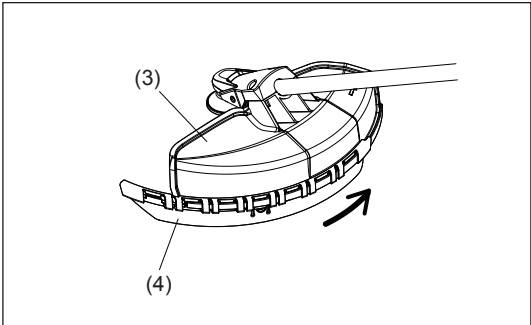

Type 4

– Fix the protector (1) to the clamp (3) with two bolts M6 x 30 (2).

NOTE: Tighten the right and left bolts evenly so that the gap between the clamp (3) and the protector (1) will be constant. Otherwise, the protector sometimes may not function as specified.

CAUTION: The outside diameter of the cutter blade must be 255mm (10"). Never use any blades surpassing 255mm (10") in outside diameter.

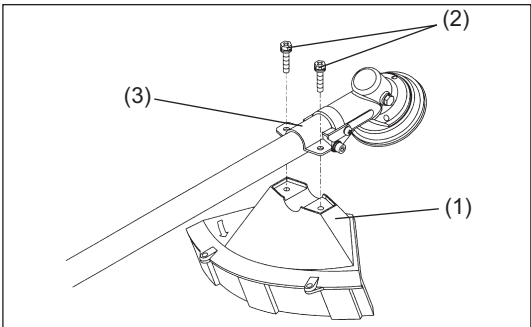

- In use of the nylon cutting head insert the protector (6) into the protector (1), and fasten them with two screw (4) and two nuts (5).

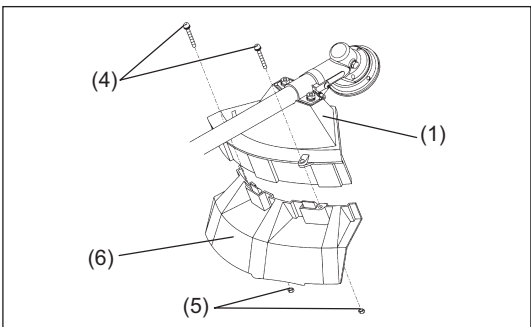

MOUNTING OF CUTTER BLADE



- Insert the hex wrench through the hole in the gear case and rotate the receiver washer (4) until it is locked with the hex wrench.
- Loosen the nut (1) (left-hand thread) with the socket wrench and remove the nut (1), cup (2), and clamp washer (3).

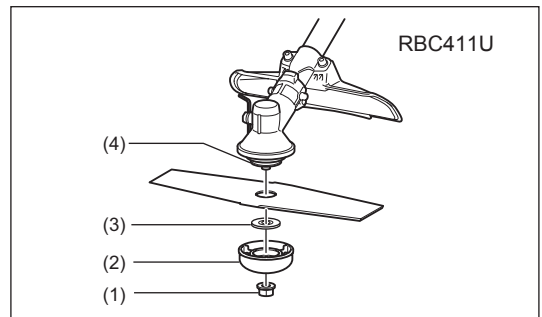
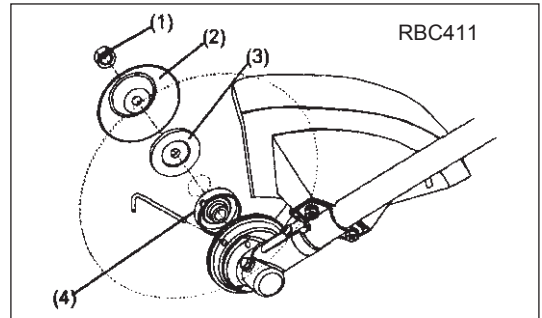

Mounting of cutter blade

With the hex wrench still in place.

- Mount the cutter blade onto the shaft so that the guide of the receiver washer (4) fits in the arbor hole in the cutter blade. Install the clamp washer (3), cup (2), and secure the cutter blade with the nut (1).
[Tightening torque: 13 - 23 N·m]

NOTE: Always wear gloves when handling the cutter blade.

NOTE: The cutter blade-fastening nut (with coned disc spring) is a consumable part.

If there appears any wear or deformation on the coned disc spring washer, replace the nut.

Make sure that the blade is the left way up.

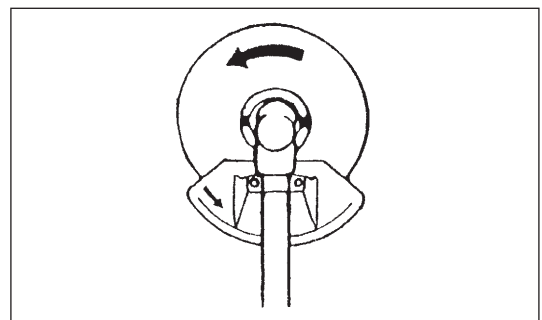
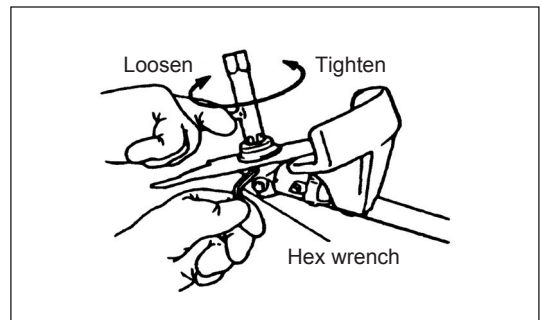

Mounting of nylon cutting head

- The clamp washer (3), cup (2), and nut (1) are not necessary for mounting the nylon cutting head. The nylon cutting head should go on top of the receiver washer (4).
- Insert the hex wrench through the hole in the gear case and rotate the receiver washer (4) until it is locked with the hex wrench.
- Then screw the nylon cutting head onto the shaft by turning it counter-clockwise.
- Remove the hex wrench.

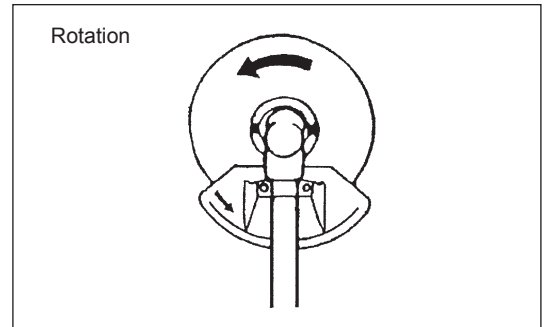
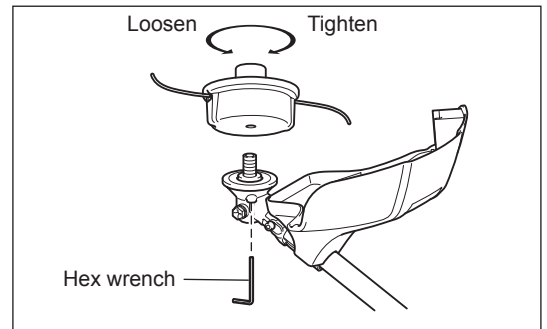



Handling petroleum products

Utmost care is required when handling fuel. Fuel may contain substances similar to solvents. Refuel either in a well ventilated area or outdoors. Do not inhale fuel vapors, avoid any contact of fuel or oil with your skin.

Mineral oil products degrease your skin. If your skin comes in contact with these substances repeatedly and for an extended period of time, various skin diseases may result. In addition, allergic reactions are known to occur. Eyes can be irritated by contact with oil, fuel etc.

If oil comes into your eyes, immediately wash them with clear water.

If your eyes are still irritated, see a doctor immediately.



Observe the Safety Instructions on page 4!

Fuel and oil mixture

The engine of the brushcutter is a high-efficiency two-stroke engine. It is run with a mixture of fuel and two-stroke engine oil. The engine is designed to use unleaded regular fuel with a min. Octane value of 91 RON. If no such fuel is available, you can use fuel with a higher octane value. This will not affect the engine, but may cause poor operating behavior.

A similar situation will arise from the use of leaded fuel. To obtain optimum engine performance and to protect your health and the environment, only unleaded fuel should be used!



For engine lubrication use a two-stroke engine oil (quality grade: TC-3), which is added to the fuel. The engine has been designed to use MAKITA two-stroke engine oil at mixture ratio of 25:1 to protect the environment. In addition, a long service life and reliable operation with a minimum emission of exhaust gasses is assured. It is absolutely essential to observe a mixture ratio of 25:1 MAKITA 2-stroke engine oil. Otherwise reliable function of the brushcutter cannot be guaranteed.

The correct mixture ratio:

Mix 25 parts gasoline with 1 part MAKITA 2-stroke engine oil (see table on right).

NOTE: For preparing the fuel-oil mixture first mix the entire oil quantity with half of the fuel required in an approved can which meets or exceeds all local code standards, then add the remaining fuel. Thoroughly shake the mixture before filling it into the brushcutter tank. It is not wise to add more engine oil than specified to ensure safe operation. This will only result in a higher production of combustion residues which will pollute the environment and clog the exhaust channel in the cylinder, the spark plugs as well as the muffler. In addition, fuel consumption will rise and the performance will be decreased.



Gasoline (premium unleaded)	+	25:1 OIL
		
1,000 cc (1L)		40 cc
5,000 cc (5L)		200 cc
10,000 cc (10L)		400 cc

Refuelling

Never perform refuelling operations in a closed, unventilated area.

The engine must be switched off!

- Thoroughly clean the area around the gas cap, to prevent dirt from getting into the fuel tank.
- Unscrew the gas cap and fill the tank with fuel.
- Never fill the fuel tank to the very top.
- Securely screw on the gas cap.
- Wipe the screw plug and tank with an absorbent after refuelling!
Allow cloths to dry and discard in a proper container.

Storage of Fuel

Fuel cannot be stored for an unlimited period of time.

Purchase only the quantity required for a 4 week operating period. Only use approved fuel storage containers.

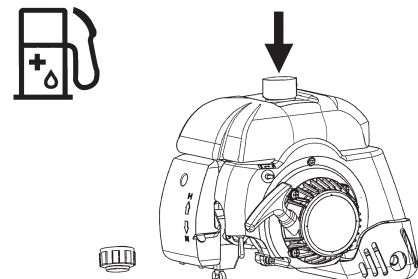

CORRECT HANDLING OF MACHINE



Either type I or II below is included in the tool package. Always wear the shoulder harness when operating the brushcutter.

Type I

Attachment of shoulder harness

- Adjust the strap length so that the cutter blade will be kept parallel with the ground.

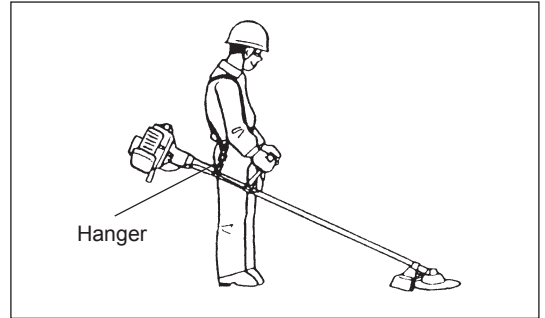

Detachment

- In case of emergency, remove the emergency detachment lever (1) by pulling strongly with a finger. The machine will detach from body. Be extremely careful to maintain control of the machine at this time. Do not allow the machine to be deflected toward you or anyone in the work vicinity.

WARNING: Failure to maintain complete control of the machine at all could result in serious bodily injury or DEATH.

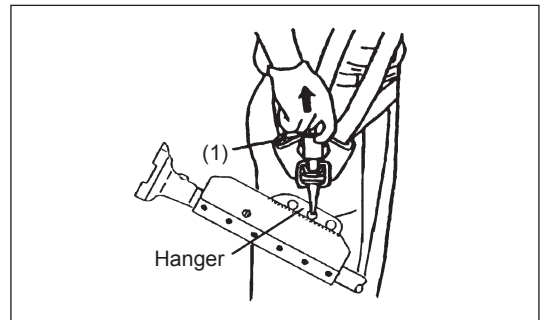

Type II

Attachment of shoulder harness

- Adjust the strap length so that the cutter blade will be kept parallel with the ground.

NOTE: Be careful not to trap clothing, etc., in the buckle.

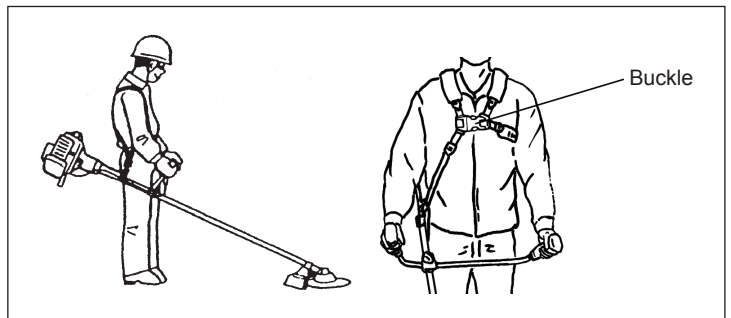

Detachment

- In case of emergency, push the notches (2) at both sides, and you can detach the machine from you. Be extremely careful to maintain control of the machine at this time. Do not allow the machine to be deflected toward you or anyone in the work vicinity.

WARNING: Failure to maintain complete control of the machine at all could result in serious bodily injury or DEATH.

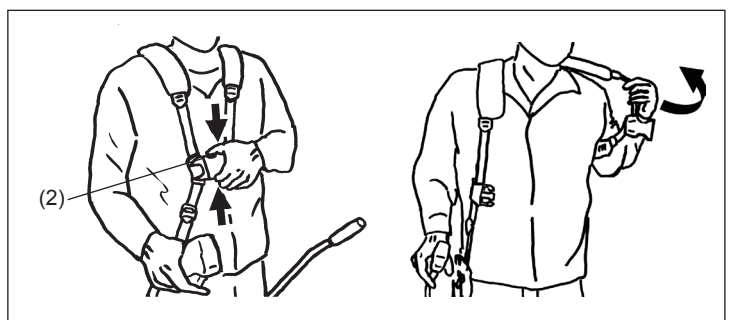

PUTTING INTO OPERATION

Observe the applicable accident prevention regulations!



Starting

Move at least 3m (10ft) away from the place of refuelling. Place the brushcutter on a clean piece of ground taking care that the cutting tool does not come into contact with the ground or any other objects.

Cold start

• For RBC411

- Push the I-O switch (1) in the direction shown by the arrow.
- Grasp the handle (hand pressure activates the safety lock-off lever (2)).
- Press the throttle lever (3) and hold it down.
- Press the lock button (4) and release the control lever, and then release the lock button (the lock button holds the throttle lever in the start-up position).

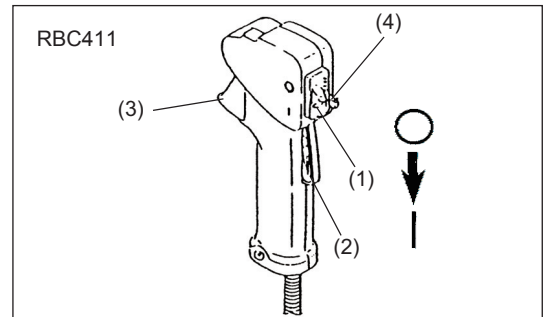

• For RBC411U

- Grasp the handle (hand pressure activates the safety lock-off lever (1)).
- Press the throttle lever (2) and hold it down.
- Push the I-O switch (3) to START.

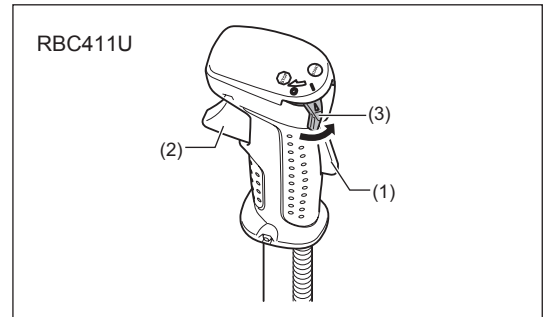

- First place the machine on the ground.
- Open the fuel valve. The valve opens when the lever (5) is at right angles to the ground (6). The valve closes when the lever is parallel with the ground (7).
- Move the choke lever (8) to the top position (I).

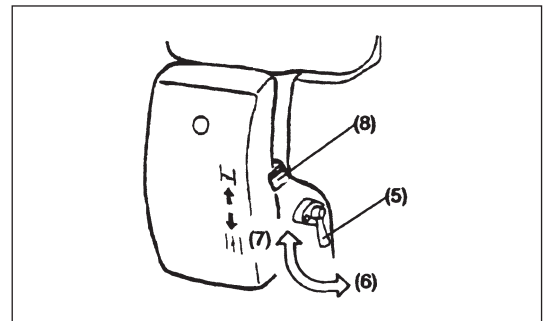

- Firmly hold the clutch case by your left hand, as illustrated.
- Slowly pull the starter grip until resistance is felt and continue with a smart pull.
- Do not pull out the starter rope to its full extent and do not allow the starter handle to be retracted without control, but ensure that it is retracted slowly.
- Repeat the starting operation until initial ignitions are heard.
- Depress the choke lever (I) and pull the starter rope again until the engine starts.
- As soon as the engine starts, immediately tap and release the throttle, thus releasing the half-throttle lock so that the engine can run in idle.
- Run the engine for approximately one minute at a moderate speed before applying full throttle.

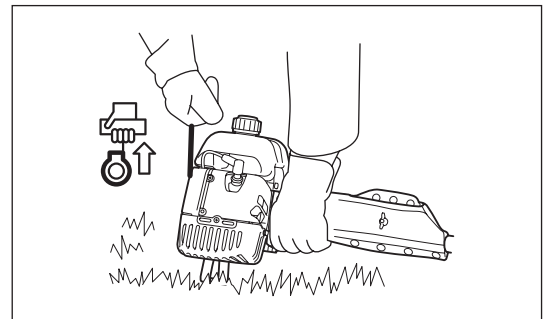

Caution during operation:

If the throttle lever is opened fully in a no-load operation, the engine rotation is increased to 10,000 min⁻¹ or more. Never operate the engine at a higher speed than required and at an approximate speed of 6,000 - 8,000 min⁻¹.

Starting the warm engine

– As described above, except without moving the choke lever (choke lever remains in the down position).

Stopping

• **For RBC411**

– Release the control lever (3) fully, and when the engine speed has lowered, push the I-O switch (1) to “O” position the engine will now stop.

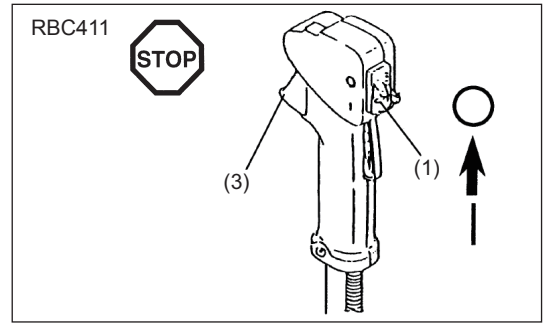

• **For RBC411U**

- 1) Release the throttle lever (2) fully, and when the engine rpm has lowered, set the I-O switch (1) to STOP the engine will now stop.
- 2) Be aware that the cutting head may not stop immediately and allow it to slow down fully.

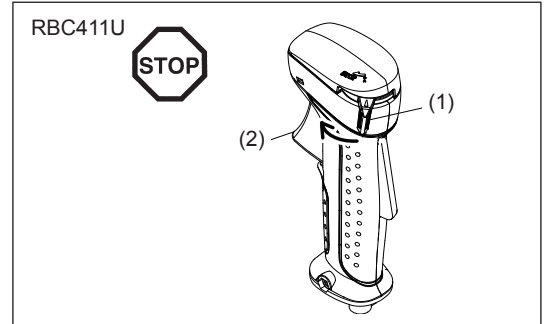

IDLE ADJUSTMENT

The cutter blade or the nylon cutting head should not run when the control lever is fully released. If necessary, adjust the idle rpm using the idle adjusting screw.

Checking the Idling speed

- Idle speed should be set to 2,600 min⁻¹. If necessary correct it by means of the idle screw (the blade or the nylon cutting head must not turn when the engine is at idle). Screwing in the screw (1) will cause an increase in the engine speed, whereas backing off the screw will reduce the engine speed.

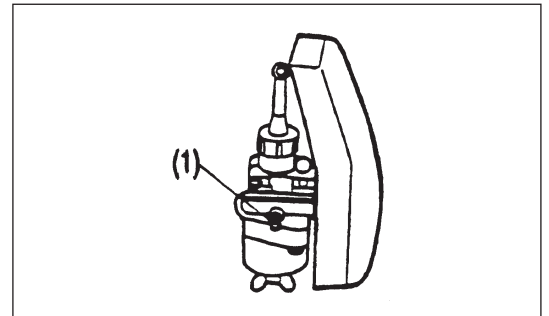

RESHARPENING THE CUTTING TOOL



CAUTION: The cutting tools mentioned below must only be reshaped by an authorized facility. Manual sharpening will result in imbalances of the cutting tool causing vibrations and damage to the equipment.

– cutter blade
An expert sharpening and balancing service is provided by Authorized Service Agents.

NOTE: To increase the service life of the cutter blade (star blade, eddy blade, saw blade) it may be turned over once, until both cutting edges have become blunt.

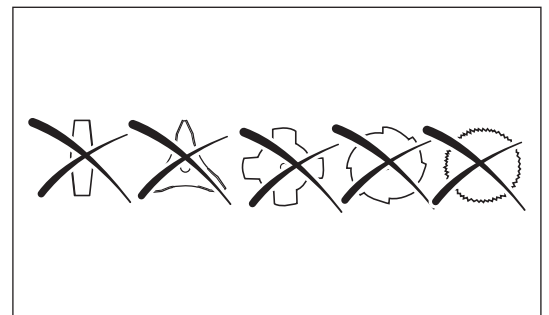

MAINTENANCE SCHEDULE

1. Before operation, pay particular attention to the tightness of Cutter Blade or nylon cutting head.
Check bolts and nuts and retighten if necessary.: Every 8 hours (Daily)
2. Check clogging of the cooling air passage and the cylinder fins. Clean them if necessary.: Every 8 hours (Daily)
3. Cleaning of air cleaner.: Every 8 hours (Daily)
 - 1) Remove the air cleaner cover (1) and clean the sponge element (2).
If there is excessive dust or dirt adhering to cleaner, clean it.
A clogged air cleaner may make it difficult or impossible to start the engine or increase the engine rotational speed.
 - 2) Install the sponge element around the ribs of the air cleaner case.
4. Checkup of spark plug.: Every 8 hours (Daily)
The gap between the two electrodes of the spark plug should be 0.6 to 0.7 mm (0.024" to 0.028").
If the gap is too wide or too narrow, adjust it.
If the spark plug is clogged with carbon or fouled, clean it thoroughly or replace it.
5. Supply of grease to gear case.
Apply grease (SHELL ALVANIA No. 3 or equivalent) to the gear case through the grease hole (3) every 30 hours.
(Genuine MAKITA grease may be purchased from your MAKITA dealer.)
6. Cleaning of muffler exhaust port: Every 50 hours (Monthly)
If the exhaust port (4) is clogged with carbon, remove it by scraping and tapping gently with a screwdriver or the like.
7. Check of fuel filter. If clogged, clean the filter.
8. Replace fuel lines.: Every 200 hours (Yearly)
9. Overhaul engine.: Every 200 hours (Yearly)
10. Replace packings and gaskets with new ones.: Every time engine is reassembled.

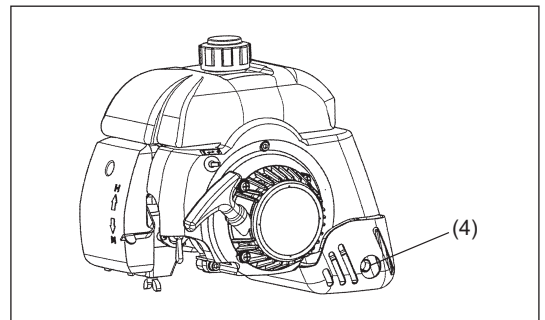
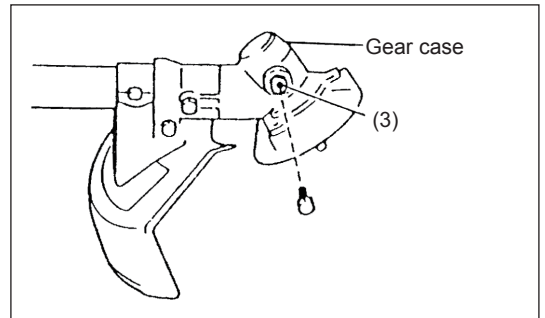
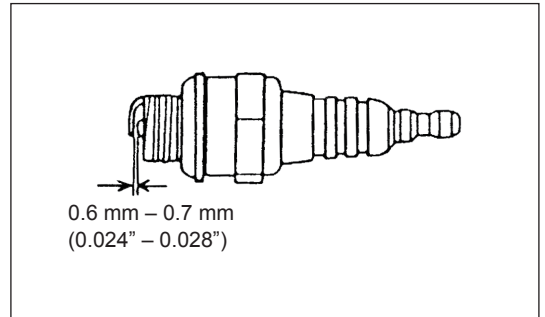
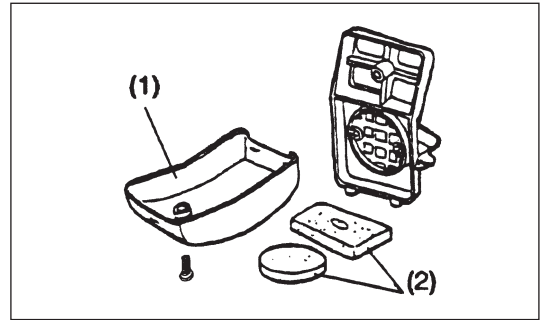

General	Engine assembly, screws and nuts	Visual inspection for damage and tightness Check for general condition and security
After each refuelling	Throttle lever Safety lock key ON-OFF switch	Functional check Functional check Functional check
Daily	Sponge element (air filter) Cooling air duct Cutting blade Idling speed	To be cleaned To be cleaned Check for damage and sharpness Inspection (cutting tool must not move)
Weekly	Spark plug Muffler	Inspection, replace if necessary Check and if necessary clean the opening
Quarterly	Suction head (gas line filter) Fuel tank	To be replaced To be cleaned
Shutting down procedure	Fuel tank Carburetor	Empty fuel tank Operate until engine runs out of fuel

STORAGE

- When the machine is in storage for a long time, drain fuel from the fuel tank and carburetor, as follows: Drain all fuel from the fuel tank. Dispose of properly and in accordance with all local laws.
- Remove the spark plug and a few drops of oil into the spark plug hole. Then, pull the starter gently, so that oil covers the engine inside and tighten the spark plug.
- Clear dirt or dust from the cutter blade and outside of engine, wipe them with a oil-immersed cloth and keep the machine in a place as dry as possible.

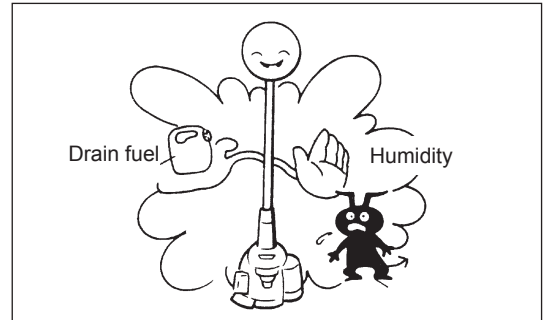

Fault location

Fault	System	Observation	Cause
Engine not starting or with difficulty	Ignition system	Ignition spark O.K.	Fault in fuel supply or compression system, mechanical defect
		No ignition spark	I-O switch operated, wiring fault or short circuit, spark plug or connector defective, ignition module faulty
	Fuel supply	Fuel tank filled	Incorrect choke position, carburetor defective, fuel supply line bent or blocked, fuel dirty
	Compression	No compression when pulled over	Cylinder bottom gasket defective, crankshaft seals damaged, cylinder or piston rings defective or improper sealing of spark plug
	Mechanical fault	Starter not engaging	Broken starter spring, broken parts inside of the engine
Warm start problems		Tank filled ignition spark existing	Carburetor contaminated, must be cleaned
Engine starts but dies immediately	Fuel supply	Tank filled	Incorrect idling adjustment, carburetor contaminated Fuel tank vent defective, fuel supply line interrupted, cable or I-O switch faulty
Insufficient performance	Several systems may simultaneously be affected	Engine idling poor	Air filter contaminated, carburetor contaminated, muffler clogged, exhaust duct in the cylinder clogged

TROUBLESHOOTING

Before making a request for repairs, check a trouble for yourself. If any abnormality is found, control your machine according to the description of this manual. Never tamper or dismount any part contrary to the description. For repairs, contact Authorized Service Agent or local dealership.

State of abnormality	Probable cause (malfunction)	Remedy
Engine does not start	Low pulling speed of starter rope	Pull strongly
	Lack of fuel	Feed fuel
	Clogged fuel filter	Clean
	Broken fuel tube	Straighten fuel tube
	Deteriorated fuel	Deteriorated fuel makes starting more difficult. Replace with new one. (Recommended replacement: 1 month)
	Excessive suction of fuel	Set throttle lever from medium speed to high speed, and pull starter handle until engine starts. Once engine starts, cutter blade starts rotating. Pay full attention to cutter blade. If engine will not start still, remove spark plug, make electrode dry, and reassemble them as they originally are. Then, start as specified.
	Detached plug cap	Attach securely
	Contaminated spark plug	Clean
	Abnormal clearance of spark plug	Adjust clearance
	Other abnormality of spark plug	Replace
	Abnormal carburetor	Make request for inspection and maintenance.
	Starter rope cannot be pulled	Make request for inspection and maintenance.
	Abnormal drive system	Make request for inspection and maintenance.
Engine stops soon Engine speed does not increase	Insufficient warm-up	Perform warm-up operation
	Choke lever is set to "CLOSE" although engine is warmed up.	Set to "OPEN"
	Clogged fuel filter	Clean
	Contaminated or clogged air cleaner	Clean
	Abnormal carburetor	Make request for inspection and maintenance.
	Abnormal drive system	Make request for inspection and maintenance.
Cutter blade does not rotate ↓ Stop engine immediately	Loosened cutter blade-tightening nut	Tighten securely
	Twigs caught by cutter blade or dispersion-preventing cover.	Remove foreign matter
	Abnormal drive system	Make request for inspection and maintenance.
Main unit vibrates abnormally ↓ Stop engine immediately	Broken, bent or worn cutter blade	Replace cutter blade
	Loosened cutter blade-tightening nut	Tighten securely
	Shifted convex part of cutter blade and cutter blade support fitting.	Attach securely
	Abnormal drive system	Make request for inspection and maintenance.
Cutter blade does not stop immediately ↓ Stop engine immediately	High idling rotation	Adjust
	Detached throttle wire	Attach securely
	Abnormal drive system	Make request for inspection and maintenance.
Engine does not stop ↓ Run engine at idling, and set choke lever to CLOSE	Detached connector	Attach securely
	Abnormal electric system	Make request for inspection and maintenance.

When the engine does not start after warm-up operation:

If there is no abnormality found for the check items, open the throttle by about 1/3 and start the engine.

Makita Corporation

Anjo, Aichi, Japan

www.makita.com

885147B9

ALA