

INSTRUCTION MANUAL

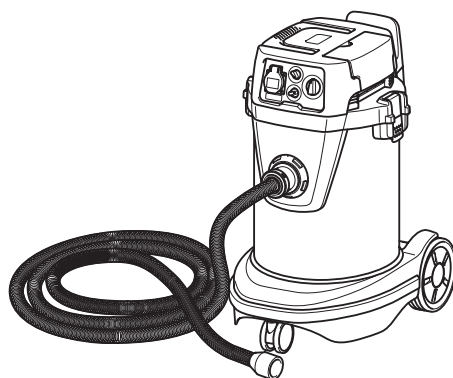



Vacuum Cleaner



VC3211H



Read before use.

SPECIFICATIONS

Model		VC3211H			
Countries		EU	Switzerland	UK	
Voltage	Volt	230-240	230-240	110	230-240
Power consumption	Watt	1050	1050	1050	1050
Connected load for appliance socket	Watt at  symbol mode	2400	1100	600	1900
	Watt at  symbol mode	2600	1400	850	2100
Total connected load	Watt	3450	2150	1650	2950





Model		VC3211H		
Countries		Middle East countries and Africa		
Voltage	Volt	110-120	230-240	220-240
Power consumption	Watt	1050	1050	1050
Connected load for appliance socket	Watt at  symbol mode	550	1900	2200
	Watt at  symbol mode	850	2100	2500
Total connected load	Watt	1600	2950	3250

Model		VC3211H	
Volume flow (air)	With ϕ 28mm X 3.5m hose	2.0 m ³ /min	
	With ϕ 38mm X 2.5m hose	3.5 m ³ /min	
Vacuum		22 kPa	
Type of protection		IP X4 (splash-proof)	
Recoverable capacity	Dust	32 L	
	Water	27 L	
Dimensions (L x W x H)		552 mm x 398 mm x 685 mm	
Net weight		17.0 kg	
Safety class		Class I	

- Due to our continuing program of research and development, the specifications herein are subject to change without notice.
- Specifications may differ from country to country.
- Weight according to EPTA-Procedure 01/2003

Symbols

The following show the symbols used for the equipment. Be sure that you understand their meaning before use.

	Read instruction manual.
	Take particular care and attention.
	Warning! The cleaner may contain hazardous dust.
	Never stand on the cleaner.
	The cleaners are capable of picking up dust class L, M and H. Follow your country's regulations relating to dusts and to occupational health and safety. Warning! This machine contains dust hazardous to health. Emptying and maintenance operations, including removal of the dust collection means, must only be carried out by authorised personnel wearing suitable personal protection. Do not operate without the full filtration system fitted.



Only for EU countries
Do not dispose of electric equipment together with household waste material! In observance of the European Directive, on Waste Electric and Electronic Equipment and its implementation in accordance with national law, electric equipment that have reached the end of their life must be collected separately and returned to an environmentally compatible recycling facility.

Intended use

The tool is intended for collecting both wet and dry dust. The tool is suitable for commercial use, for example in hotels, schools, hospitals, factories, shops, offices and rental businesses.

Power supply

The tool should be connected only to a power supply of the same voltage as indicated on the nameplate, and can only be operated on single-phase AC supply. This tool should be grounded while in use to protect the operator from electric shock. Use only three-wire extension cords which have three-prong grounding-type plugs and three-pole receptacles which accept the tool's plug.

Noise

The typical A-weighted noise level determined according to EN/IEC60704:

Sound pressure level ($L_{p(A)}$) : 72.5 dB (A)

Uncertainty (K) : 2.5 dB (A)

The noise level under working may exceed 80 dB (A).

Wear ear protection

Vibration

The vibration total value (tri-axial vector sum) determined according to EN/IEC60335:

The vibration emission value is below 2.5 m/s².

For European countries only

EC Declaration of Conformity

Makita declares that the following Machine(s):

Designation of Machine:

Vacuum Cleaner

Model No./ Type: VC3211H

Conforms to the following European Directives:

2006/42/EC

They are manufactured in accordance with the following standard or standardized documents:

EN60335

The technical file in accordance with 2006/42/EC is available from:

Makita, Jan-Baptist Vinkstraat 2, 3070, Belgium

31.7.2014



Yasushi Fukaya
Director

Makita, Jan-Baptist Vinkstraat 2, 3070, Belgium

VACUUM CLEANER SAFETY WARNINGS

⚠WARNING! IMPORTANT READ CAREFULLY all safety warnings and all instructions BEFORE USE.

Failure to follow the warnings and instructions may result in electric shock, fire and/or serious injury.

- 1. Before use, make sure that this cleaner must be used by people who have been adequately instructed on the use of this cleaner.**
- 2. Only use the socket outlet on the cleaner for purposes specified in the instructions.**
- 3. If foam/liquid comes out, switch off immediately.**
- 4. Clean the water level limiting device regularly and examine it for signs of damage.**
- 5. Do not use the cleaner without the filter. Replace a damaged filter immediately.**
- 6. USE OF EXTENSION CORD.** When using an extension cord because of the great distance to your power source, try to employ a cord that is sufficiently thick but not too long, or cleaner performance will be adversely affected. For outdoor applications use an extension cord suitable for outdoor use.
- 7. VOLTAGE WARNING:** Before connecting the cleaner to a power source (receptacle, outlet, etc.) be sure the voltage supplied is the same as that specified on the nameplate of the cleaner. A power source with voltage greater than that specified for the cleaner can result in **SERIOUS INJURY** to the operator as well as damage to the cleaner. If in doubt, **DO NOT PLUG IN THE CLEANER.** Using a power source with voltage less than the nameplate rating is harmful to the motor.
- 8. AVOID UNINTENTIONAL STARTING.** Be sure switch is OFF when plugging in.
- 9. Do not attempt to pick up flammable materials, fire works, lighted cigarettes, hot ashes, hot metal chips, sharp materials such as razors, needles, broken glass or the like.**
- 10. NEVER USE THE CLEANER IN THE VICINITY OF GASOLINE, GAS, PAINT, ADHESIVES OR OTHER HIGHLY EXPLOSIVE SUBSTANCES.** The switch emits sparks when turned ON and OFF. And so does the motor commutator during operation. A dangerous explosion may result.
- 11. After vacuuming up toxic, carcinogenic or pathogenic, or other hazardous materials such as asbestos, arsenic, barium, beryllium, lead, pesticides, or other health endangering materials, bring the machine to authorised institution for cleaning and disposal of those hazardous dusts in accordance with your country's regulation.**
- 12. Never vacuum up combustible dusts or materials.**
- 13. Never use the cleaner outdoors in the rain.**
- 14. Do not use close to heat sources (stoves, etc.).**
- 15. GUARD AGAINST ELECTRIC SHOCK.** Prevent body contact with grounded surfaces. For example; pipes, radiators, ranges, refrigerator enclosures.
- 16. Do not block cooling vents.** These vents permit cooling of the motor. Blockage should be carefully avoided otherwise the motor will burn out from lack of ventilation.
- 17. Keep proper footing and balance at all times.**
- 18. DO NOT ABUSE CORD.** Never carry the cleaner by cord or yank it to disconnect from receptacle. Keep cord away from heat, oil, and sharp edges. Inspect cleaner cords periodically and if damaged, have repaired by authorized service facility. Inspect extension cords periodically and replace if damaged.
- 19. Do not fold, tug or step on the hose.**
- 20. Stop the cleaner immediately if you notice poor performance or anything abnormal during operation.**
- 21. DISCONNECT THE CLEANER.** When not in use, before servicing, and when changing accessories.
- 22. Clean and service the cleaner immediately after each use to keep it in tiptop operating condition.**
- 23. MAINTAIN THE CLEANER WITH CARE.** Keep the cleaner clean for better and safer performance. Follow instructions for changing accessories. Keep handles dry, clean, and free from oil and grease.

24. **CHECK DAMAGED PARTS.** Before further use of the cleaner, a guard or other part that is damaged should be carefully checked to determine that it will operate properly and perform its intended function. Check for alignment of moving parts, binding of moving parts, breakage of parts, mounting, and any other conditions that may affect its operation. A guard or other part that is damaged should be properly repaired or replaced by an authorized service center unless otherwise indicated elsewhere in this instruction manual. Have defective switches replaced by authorized service center. Don't use the cleaner if switch does not turn it on and off.
25. **REPLACEMENT PARTS.** When servicing, use only identical replacement parts.
26. **STORE IDLE CLEANER.** When not in use, the cleaner should be stored indoors.
27. **Be kind to your cleaner.** Rough handling can cause breakage of even the most sturdily built cleaner.
28. **Do not attempt to clean the exterior or interior with benzene, thinner or cleaning chemicals.** Cracks and discoloration may be caused.
29. **Do not use cleaner in an enclosed space where flammable, explosive or toxic vapors are given off by oil-base paint, paint-thinner, gasoline, some mothproofing substances, etc., or in areas where flammable dust is present.**
30. **Do not leave the cleaner cord lying on the floor after you have finished a cleaning job.** It can become a tripping hazard or may cause damage to the cleaner.
31. **Do not operate this or any tool while under the influence of drugs or alcohol.**
32. **As a basic rule of safety, use safety goggles or safety glasses with side shields.**
33. **Use a dust mask in dusty work conditions.**
34. **This machine is not intended for use by persons including children with reduced physical, sensory or mental capabilities, or lack of experience and knowledge.**
35. **Young children should be supervised to ensure that they do not play with the cleaner.**
36. **Never handle plug cord or cleaner with wet hands.**
37. **Use extreme caution when cleaning on stairs.**
38. **Do not use the cleaner as a stool or work bench.** The machine may fall down and may result in personal injury.

KEEP FOR FUTURE REFERENCE

⚠WARNING: DO NOT let comfort or familiarity with product (gained from repeated use) replace strict adherence to safety rules for the subject product. MISUSE or failure to follow the safety rules stated in this instruction manual may cause serious personal injury.

FUNCTIONAL DESCRIPTION

⚠WARNING:

- Before plugging the cleaner, always make sure that the cleaner is switched off. Plugging the cleaner with the switch on may cause an unexpected start resulting in serious personal injury.

Switch action

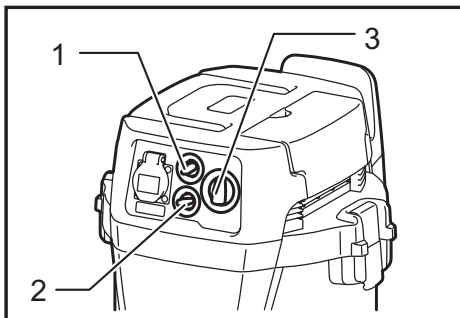

- 1. Suction force adjusting knob 2. Hose diameter selection dial 3. Switch lever

To start the cleaner, rotate the switch lever to the "I" side. To stop it, rotate the switch lever to the "O" side.

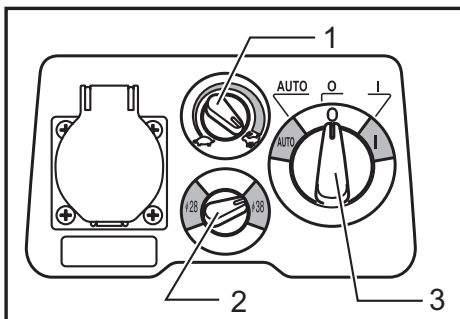

- 1. Suction force adjusting knob 2. Hose diameter selection dial 3. Switch lever

The suction force can be adjusted according to your work need.

Suction force can be increased by turning the suction force adjusting knob from the symbol to the symbol.

Also, set the hose diameter selection dial to the hose's diameter that you are going to use.

Hose diameter selection dial

Turn the dial direction in accordance with the hose you use.

NOTE: Do not set the dial at the middle. Always turn either side according to the hose diameter.

Warning beep

There are two types of beeping sound. One is short beeps, and the other is long beep.

When the air flow speed falls under 20 m/s, the cleaner emits short warning beeps for safety reasons. When it sounds, check the hose diameter selection dial or if the suction force is not too low. If the beeps keep sounding, perform maintenance or ask your local service center. When the tank is filled with liquid, the cleaner emits long warning beep.

When the tank is full and the beep sounds, switch off the cleaner and empty the tank.

Connecting electric power tools

⚠ WARNING:

- Make sure that both the cleaner and the electric power tool are switched off before connecting or disconnecting. Connecting the power tool to the cleaner with both of them being switched on may cause unexpected and sudden start resulting serious personal injury.
- Never connect an electric power tool with an input power exceeding that specified in the "SPECIFICATIONS" to the socket of the cleaner by turning the suction force adjusting knob. Connecting the electric power tool exceeding the specified input power may cause overheating and damage to the cleaner.
- When connecting a grounded tool, insert a plug with a grounding plate to the socket of the cleaner.

The cleaner can be connected to an electric power tool up to input power shown in the "SPECIFICATIONS".

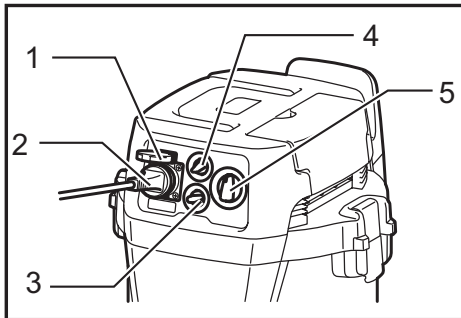

- 1. Outlet cap 2. Power supply cord 3. Hose diameter selection dial 4. Suction force adjusting knob 5. Switch lever

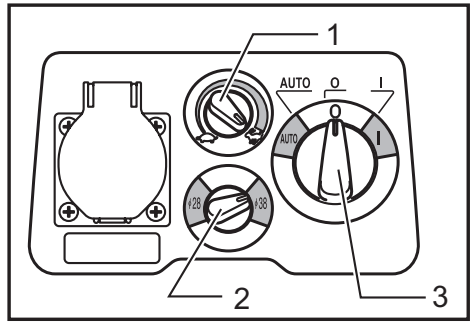

- 1. Suction force adjusting knob 2. Hose diameter selection dial 3. Switch lever

1. To connect an electric power tool, open the outlet cap and insert the power tool plug into the socket of the cleaner.

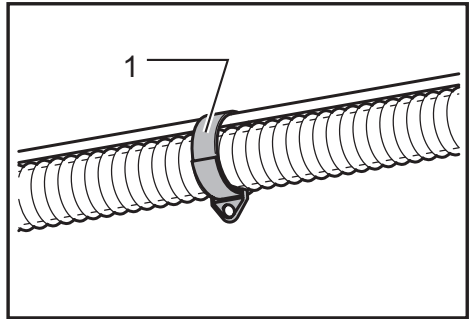

- 1. Hose band

2. When connecting an electric power tool, secure the power supply cord and hose by the hose bands at regular distance. It prevents the hose from tangling the power supply cord.
3. Rotate the switch lever to the "AUTO" position.
4. Move the suction force adjusting knob to the position suitable for the input power of the electric power tool you intend to use.
5. Switching on and off of the connected electric power tool simultaneously brings the cleaner switching on and off action. The cleaner still works for a few seconds even after the electric power tool is switched off.
6. After use, disconnect the power tool from the socket of cleaner.
7. Switch off the cleaner after use.

Auto-suction stop during suction operation

⚠ WARNING:

- **Do not pick up foam or soapy liquid.** Picking up foam or soapy liquid can cause foam to come out of air exit before the auto-suction stop works. Continuing to using in this condition may cause an electric shock and breakage of the cleaner.

The cleaner has a mechanism that prevents water from immersing into the motor when picking up more than a certain amount of water.

When the tank is full with liquid, the cleaner emits long warning beep. Switch off the cleaner and empty the tank when this beep sounds.

Usage of base hook

⚠ CAUTION:

- **Be careful not to pinch your fingers when closing the base hook.** Failure to do so may cause personal injury.

NOTICE:

- Do not apply an excessive force on the base hook. The excessive force on the base hook may damage the base hook. Close the base hook when not in use.

Opening the base hook allows the following usage.

1. Storing the power supply cord

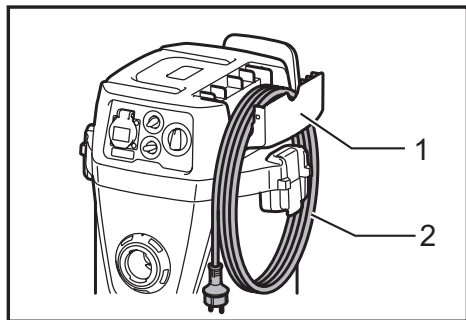

▶ 1. Base hook 2. Power supply cord

NOTICE:

- **Do not use the cleaner or a connected electric power tool with a power supply cord wound on the base hook.** Using the cleaner or the connected electric power tool with power supply cord may cause damage to the power supply cord.

2. Storing the front cuffs

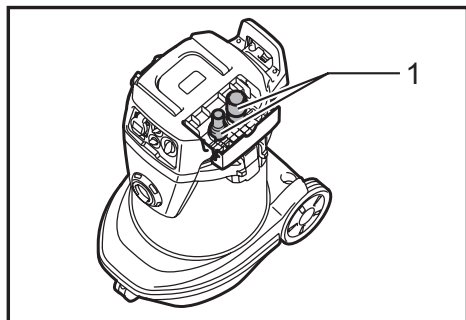

▶ 1. Front cuffs

Front cuffs 22, 24 and 38 can be stored (up to two at a time).

3. Storing the hose

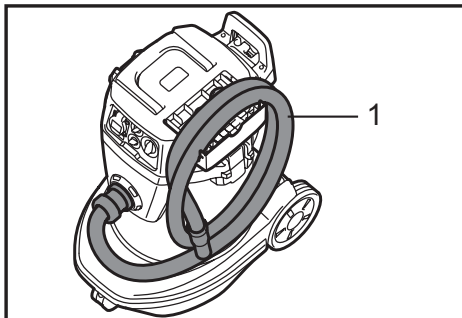

▶ 1. Hose

4. Resting a reasonable size of electric power tool for the base hook, such as circular saw

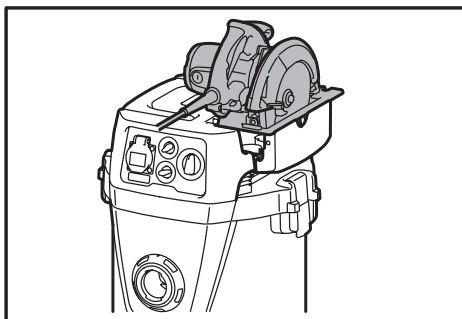

Locking or unlocking the caster

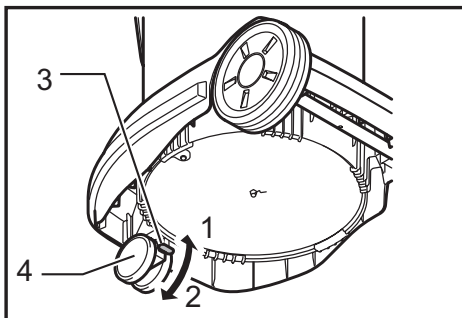

▶ 1. FREE position 2. LOCK position 3. Stopper lever 4. Caster

To lock the caster with a stopper, lower the stopper lever and the caster no longer will rotate. To release the caster from the locked position, raise the stopper lever. Locking the caster is convenient when storing the cleaner, stopping the work on the way and keeping the cleaner still.

To operate the stopper, move it by hand.

NOTICE:

- When moving the cleaner, make sure that the caster is unlocked. Moving the cleaner with the caster in the locked position may cause damage to the caster.

Cap

There is a cap on the mounting port. The cap prevents the vacuumed dust from getting out from the cleaner.

ASSEMBLY

⚠ WARNING:

- This unit may contain hazardous dust. When replacing filter elements and dust bag, always use a P2-respirator.
- Always be sure that the cleaner is switched off and unplugged before carrying out any work on the cleaner.
- Never switch on until all filters and dust bag are completely installed and the volume flow control is tested.

Warning sticker

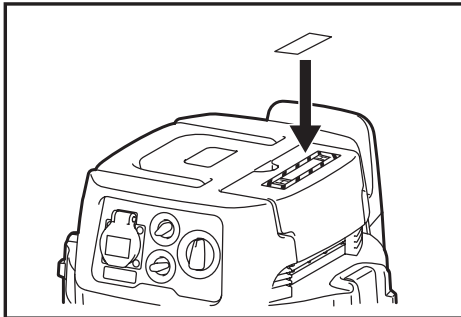

Put the warning sticker of your language in the frame of warning label on the cleaner.

Installing and disposing the filter bag

⚠ WARNING:

- Always use a P2-respirator.
- When using the filter bag, also use the air filter together that is preinstalled on the tool. Failure to use the air filter together may cause unusual noise and heat, resulting in a fire.

⚠ CAUTION:

- Never pick up water or other liquids or wet dusts when using the filter bag. Picking up such things may cause the filter bag breakage.

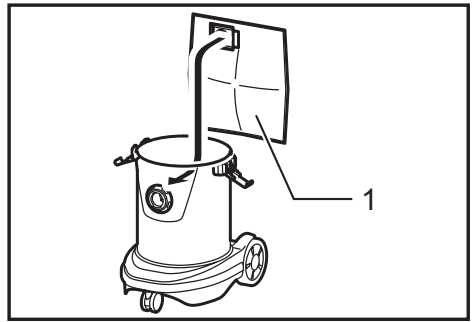

► 1. Filter bag

1. Extend the filter bag.

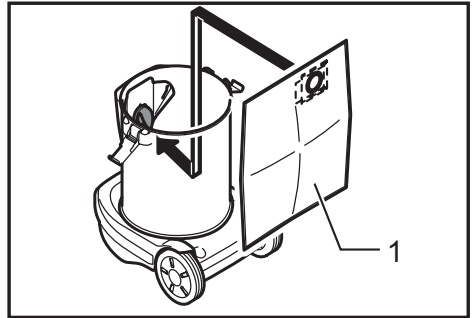

► 1. Filter bag

2. Align the filter bag opening with the dust suction opening of the cleaner.
3. Insert the cardboard of the filter bag onto the tool so that it is positioned at the end beyond the detent protrusion.

When disposing the filter bag, pull the edge on the filter bag's mouth so that the mouth is closed by a paper.

Connecting a hose

⚠ CAUTION:

- Never force the hose for bending or stamp it. Never move the cleaner by a hose. Forcing, stamping and pulling the hose may cause a breakage or deformation of the hose.
- When picking up large wastes such as planer carvings, concrete dusts or similar other than small wastes, use the 38 mm inner diameter hose (optional accessory). Using the 28 mm inner diameter hose may cause a hose stuffing and damage.
- Always put the cap on the mounting port whenever you remove the hose from the tool.

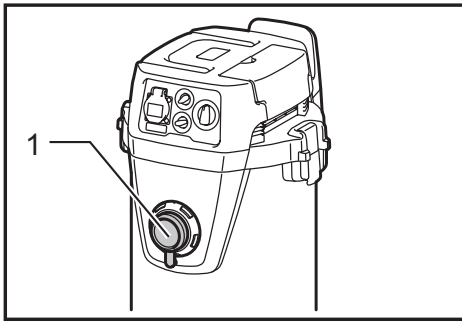

► 1. Cap

Remove the cap from the mounting port. You can place the cap in multi hook while the hose is connected to the tool.

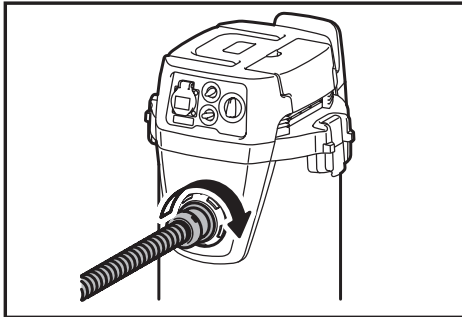

Insert the hose onto the mounting port of the tank and turn it clockwise until it locks.

OPERATION

⚠ WARNING:

- Always use a P2-respirator.

⚠ CAUTION:

- If foam or liquid escapes from the tool, switch off immediately. Continuing to using in this condition may cause an electric shock and breakage of the cleaner.

MAINTENANCE

⚠ WARNING:

- Always use a P2-respirator during performing maintenance.
- Never reuse the air filter after removal of the machine.

⚠ CAUTION:

- Always be sure that the tool is switched off and unplugged before attempting to perform inspection or maintenance.
- Never use gasoline, benzine, thinner, alcohol or the like. Discoloration, deformation or cracks may result.
- Please check with your local authorities for any regulations regarding the use of these vacuum cleaners when working with toxic materials such as Asbestos.
- Before any repair or maintenance always check what materials the vacuum cleaner has been working with. In if doubt, always have professionally cleaned by licensed asbestos / toxic cleaning company before conducting any repair or maintenance.
- A technical inspection, including inspection of filters, air tightness, and control mechanism, must be performed by an instructed person at least once a year, or more frequently as may be specified by national requirements.
- During maintenance, all contaminated items which cannot be satisfactorily cleaned must be disposed. Such items must be disposed of in impervious bags which accord with your country's regulations.
- After the operation in the hazardous area, the outside of the tool must be decontaminated by vacuum cleaning methods and wiped clean or treated with sealant before you take the tool out of a hazardous area. All the parts of the tool must be regarded as contaminated when removed from the hazardous area, and appropriate action must be taken to prevent dust dispersal.
- Change the air filter when the air filter is clogged with dust or you feel that the cleaner's performance declined.
- Check the filters periodically. If there is a tear on it, replace it immediately.

Removing the air filter

⚠ CAUTION:

- Wait for about 5 minutes so that dust in the tank completely settles down.
- Make sure that the tool is unplugged.
- Be careful not to let the dust enter inside the tank cover when removing the air filter.

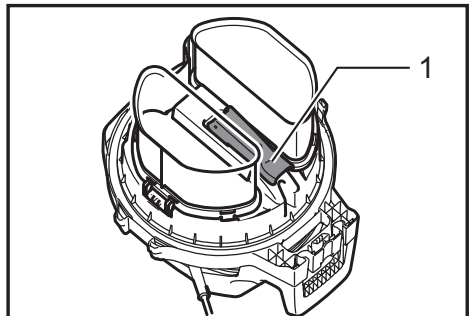

► 1. Stopper lever

Unhook the tank cover and remove it carefully. Put it up side down.

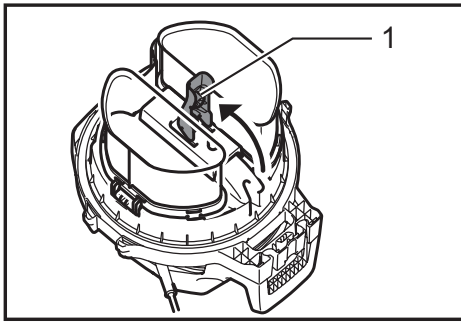

► 1. Stopper lever

Remove the screw on the stopper lever.
Unlock the filter hooks by flipping the stopper lever.

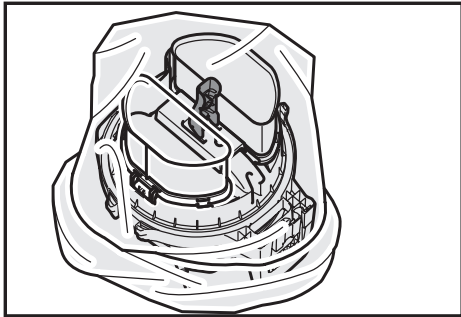

Cover the air filters with a plastic bag.

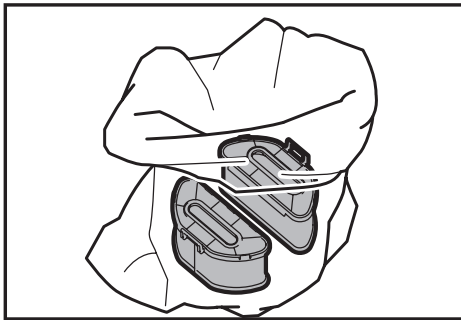

Remove the air filters from the tank cover carefully and tie the plastic bag firmly.

Assembling the air filter

When you get the air filter components separately, assemble them as follows.

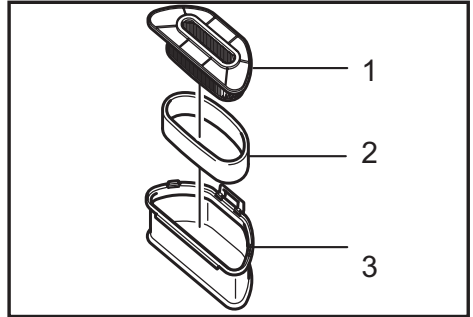

► 1. Powder filter 2. Damper 3. Prefilter

Put the prefilter over the powder filter.

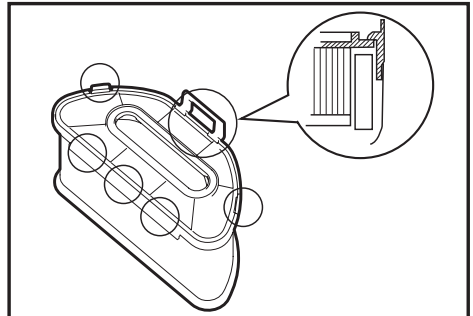

Make sure that the borders of prefilter and powder filter are set properly.

Installing the air filter

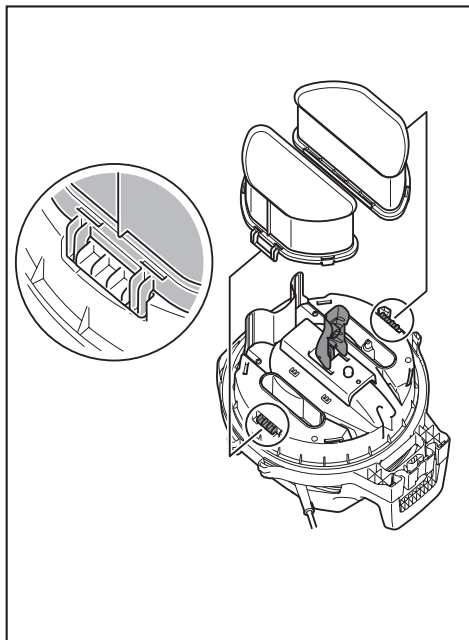

Wipe off the seal face.

Set the new air filters and fix them with the filter hooks.

Flip the stopper lever to lock the air filters.

Lock the filter hooks with the screws.

Set the tank cover onto the tank and lock it with hooks.

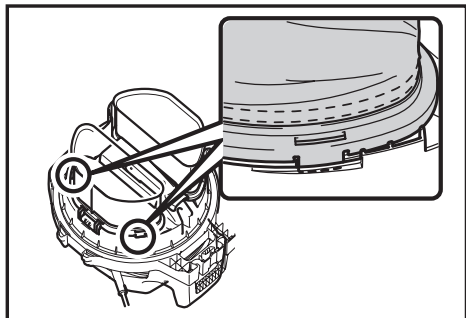

NOTICE:

- Make sure the hooks on the filters are set at the correct position.

Cleaning the level sensors

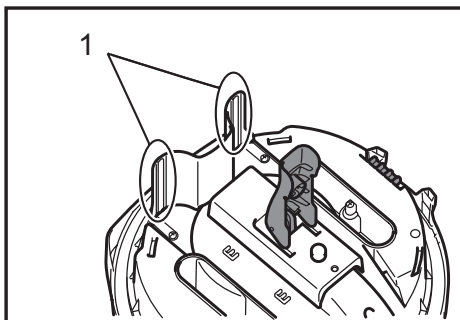

► 1. Level sensors

The level sensors detect liquid when the tank becomes full with liquid. Clean the level sensors with a soft cloth from time to time when changing the air filters.

Storage of power supply cord

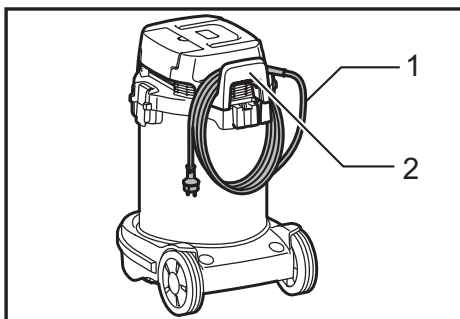

► 1. Power supply cord 2. Multi-hook

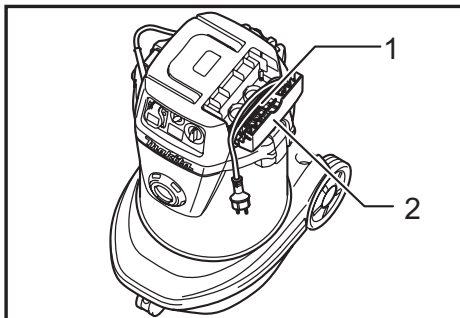

► 1. Power supply cord 2. Base hook

Wind up the power supply cord around the multi-hook or the base hook.

Storage of accessories

NOTE:

- Do not apply an excessive force to the accessories that are held by the pipe holder. Applying an excessive force to these accessories may cause damage to the pipe holder.



Pipe rest can be used to store straight pipe, bent pipe and others by just inserting these accessories.

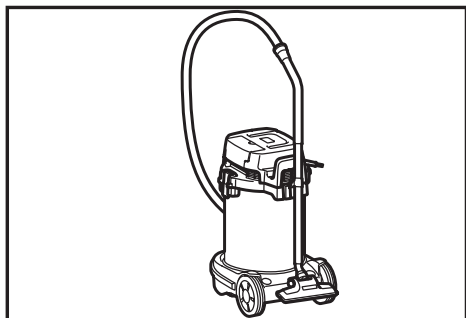

The pipes can be placed into the pipe holder when also stopping using the cleaner on the way for a while.

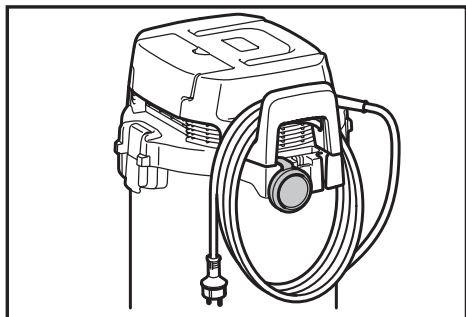

You can place the cap in multi hook while the hose is connected to the tool.

Storage of hose

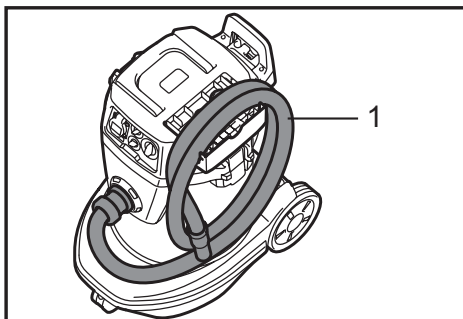
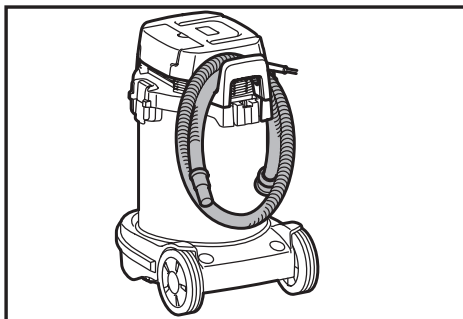

► 1. Hose

The hose can be placed on either base hook or multi-hook. To maintain product SAFETY and RELIABILITY, repairs, any other maintenance or adjustment should be performed by Makita Authorized Service Centers, always using Makita replacement parts.

OPTIONAL ACCESSORIES

▲ CAUTION:

- These accessories or attachments are recommended for use with your Makita tool specified in this manual. The use of any other accessories or attachments might present a risk of injury to persons. Only use accessory or attachment for its stated purpose.

If you need any assistance for more details regarding these accessories, ask your local Makita Service Center.

- Hose
- Front cuffs (22, 24, 38)
- Straight pipe
- Corner nozzle
- Round brush
- Powder filter
- Damper
- Prefilter
- Nozzle assembly
- Bent pipe
- Filter bag
- Hose band

- Belt hook complete
- Cap

NOTE:

- Some items in the list may be included in the tool package as standard accessories. They may differ from country to country.

Makita Europe N.V. Jan-Baptist Vinkstraat 2,
3070 Kortenberg, Belgium

Makita Corporation 3-11-8, Sumiyoshi-cho,
Anjo, Aichi 446-8502 Japan

www.makita.com

885232E224
EN
20180508